

CATALOGO GENERALE

RIDUTTORI EPICICLOIDALI

GENERAL CATALOGUE

PLANETARY REDUCTION GEARS

GESAMTKATALOG

PLANETENGETRIEBE

CATALOGUE GÉNÉRAL

REDUCTEURS EPICYCLOIDaux

CATÁLOGO GENERAL

REDUCTORES EPICICLOIDALES

CATÁLOGO GERAL

REDUTORES EPICICLOIDAIS

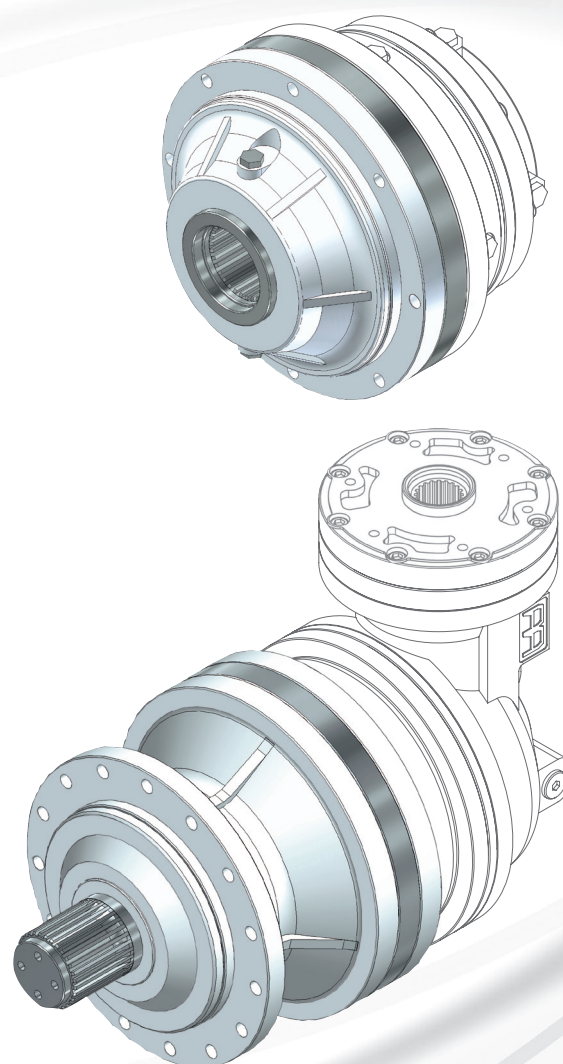

RR65 ÷ RR1700

SERIE
2000

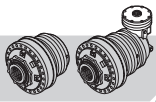

INDICE

INDEX

INHALTSVERZEICHNIS

| A Informazioni generali | <i>General information</i> | <i>Allgemeine Informationen</i> | |
|--|---|---|-------|
| 1 SIMBOLOGIA | 1 <i>SYMBOLS</i> | 1 VERWENDETE SYMBOLE | A-2 |
| 2 IDENTIFICAZIONE DEL PRODOTTO | 2 <i>PRODUCT IDENTIFICATION</i> | 2 PRODUKTKENNZEICHNUNG | A-4 |
| 3 CARATTERISTICHE TECNICHE | 3 <i>TECHNICAL CHARACTERISTICS</i> | 3 TECHNISCHE BESCHREIBUNG | A-8 |
| 4 SELEZIONE DEI RIDUTTORI | 4 <i>SELECTING THE REDUCTION GEARS</i> | 4 AUSWAHL VOM PLANETENGE- TRIEBE | A-24 |
| 5 VERIFICHE | 5 <i>CHECKS</i> | 5 KONTROLLEN | A-30 |
| 6 LUBRIFICAZIONE | 6 <i>LUBRICATION</i> | 6 SCHMIERUNG | A-40 |
| 7 IMBALLO, MOVIMENTAZIONE E STOCCAGGIO | 7 <i>PACKING, HANDLING AND STORING</i> | 7 VERPACKUNG, TRANSPORT UND LAGERUNG | A-68 |
| B Dati tecnici e dimensionali | <i>Technical and size data</i> | <i>Technische Daten und Abmessungen</i> | |
| 8 COPPIE NOMINALI | 8 <i>NOMINAL TORQUES</i> | 8 NENNDREHMOMENTE | B-3 |
| 65 | 65 | 65 | B-4 |
| 105 | 105 | 105 | B-14 |
| 110 | 110 | 110 | B-26 |
| 210 | 210 | 210 | B-38 |
| 310 | 310 | 310 | B-50 |
| 510 | 510 | 510 | B-64 |
| 710 | 710 | 710 | B-78 |
| 810 | 810 | 810 | B-92 |
| 1010 | 1010 | 1010 | B-106 |
| 1700 | 1700 | 1700 | B-120 |
| C Configurazioni e accessori in ingresso, installazione | <i>Input configurations and accessories, installation</i> | <i>Konfigurationen und Zubehör am Eingang, Installation</i> | |
| 9 CONFIGURAZIONI INGRESSO | 9 <i>INPUT CONFIGURATIONS</i> | 9 EINGANGSKONFIGURATIO- NEN | C-3 |
| 10 ENTRATE VELOCI | 10 <i>HIGH-SPEED INPUTS</i> | 10 SCHNELLE EINGÄNGE | C-10 |
| 11 FRENI | 11 <i>BRAKES</i> | 11 BREMSEN | C-12 |
| 12 ACCOPPIAMENTI PER MOTORI IDRAULICI ED ELETTRICI | 12 <i>HYDRAULIC AND ELECTRIC MOTORS COUPLINGS</i> | 12 KUPPLUNGEN FÜR HYDRAULIK- MOTOREN UND ELEKTRO- MOTOREN | C-14 |
| 13 NORME PER L'INSTALLAZIONE | 13 <i>INSTALLATION INSTRUCTIONS</i> | 13 INSTALLATIONSVORSCHRIF- TEN | C-30 |

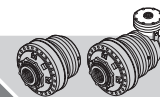

INDEX

INDICE

INDICE

A Informations générales

Información general

Informações gerais

| | | | | | | |
|---|------------------------------------|---|--|---|---------------------------------------|------|
| 1 | SYMBOLES | 1 | SIMBOLOGÍA | 1 | SIMBOLOGIA | A-2 |
| 2 | IDENTIFICATION DU PRODUIT | 2 | IDENTIFICACIÓN DEL PRODUCTO | 2 | IDENTIFICAÇÃO DO PRODUTO | A-4 |
| 3 | CARACTERISTIQUES TECHNIQUES | 3 | CARACTERÍSTICAS TÉCNICAS | 3 | CARACTERÍSTICAS TÉCNICAS | A-8 |
| 4 | SELECTION DES REDUCTEURS | 4 | SELECCIÓN DE LOS REDUCTORES | 4 | SELEÇÃO DOS REDUTORES | A-24 |
| 5 | CONTROLES | 5 | COMPROBACIONES | 5 | VERIFICAÇÕES | A-30 |
| 6 | LUBRIFICATION | 6 | LUBRICACIÓN | 6 | LUBRIFICAÇÃO | A-40 |
| 7 | EMBALLAGE, MANUTENTION ET STOCKAGE | 7 | EMBALAJE, DESPLAZA MIENTO Y ALMACENAMIENTO | 7 | EMBALAGEM, MOVIMENTAÇÃO E ARMAZENAGEM | A-68 |

B Données techniques et dimensionnelles

Datos técnicos y dimensionales

Dados técnicos e dimensionais

| | | | | | | |
|---|------------------|---|-----------------|---|----------------|-------|
| 8 | COUPLES NOMINAUX | 8 | PARES NOMINALES | 8 | PARES NOMINAIS | B-3 |
| | 65 | | 65 | | 65 | B-4 |
| | 105 | | 105 | | 105 | B-14 |
| | 110 | | 110 | | 110 | B-26 |
| | 210 | | 210 | | 210 | B-38 |
| | 310 | | 310 | | 310 | B-50 |
| | 510 | | 510 | | 510 | B-64 |
| | 710 | | 710 | | 710 | B-78 |
| | 810 | | 810 | | 810 | B-92 |
| | 1010 | | 1010 | | 1010 | B-106 |
| | 1700 | | 1700 | | 1700 | B-120 |

C Configurations et accessoires à l'entrée, installation

Configuraciones y accesorios en entrada, instalación

Configurações e acessórios entrada, instalação

| | | | | | | |
|----|---|----|---|----|---|------|
| 9 | CONFIGURATIONS A L'ENTREE | 9 | CONFIGURACIONES EN ENTRADA | 9 | CONFIGURAÇÕES ENTRADA | C-3 |
| 10 | ENTREES RAPIDES | 10 | ENTRADAS RÁPIDAS | 10 | ENTRADAS RÁPIDAS | C-10 |
| 11 | FREINS | 11 | FRENOS | 11 | FREIOS | C-12 |
| 12 | ACCOUPEMENTS POUR MOTEURS HYDRAULIQUES ET ELECTRIQUES | 12 | ACOPLAMIENTOS PARA MOTORES HIDRÁULICOS Y ELÉCTRICOS | 12 | ACOPLAGENS PARA MOTORES HIDRÁULICOS E ELÉTRICOS | C-14 |
| 13 | NORMES POUR L'INSTALLATION | 13 | NORMAS PARA LA INSTALACIÓN | 13 | NORMAS PARA A INSTALAÇÃO | C-30 |

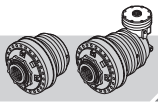

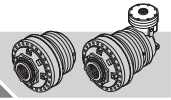

A

Informazioni generali
General information
Allgemeine Informationen
Informations générales
Información general
Informações gerais

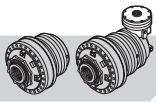

1 SIMBOLOGIA

1 SYMBOLS

1 VERWENDETE SYMBOLE

| Simbolo Symbol Symbol | Unità di misura Unit of measure Maßeinheit | Descrizione | Description | Beschreibung |
|-----------------------------|--|--|---|--|
| C_{rt} | - | Coefficiente di scambio termico | Energy exchange coefficient | Wärmeaustauschkoeffizient |
| $k_{r,1}, k_{r,2}$ | - | Coefficienti correttivi del carico radiale in entrata/uscita | Corrective coefficients of the input/output radial load | Korrekturkoeffizient Querlast am Eingang/Ausgang |
| $f_{h,1}, f_{h,2}$ | - | Fattore di durata in entrata/uscita | Input/output duration factor | Zeitfaktor Eingang/Ausgang |
| $F_{r,1}, F_{r,2}$ | N | Carico radiale ammissibile sull'albero di entrata/uscita | Permitted radial load on the input/output shaft | Zulässige Querlast auf Eingangs-/Ausgangswelle |
| $F_{a,2}$ | N | Carico assiale ammissibile sull'albero di uscita | Permitted axial load on the output shaft | Zulässige Achslast auf Ausgangswelle |
| f_s | - | Fattore di servizio | Service factor | Betriebsfaktor |
| η | - | Rendimento dinamico | Dynamic efficiency | Wirkungsgrad |
| h_r | h | Durata richiesta | Duration required | Verlangte Dauer |
| i | - | Rapporto di riduzione | Reduction ratio | Untersetungsverhältnis |
| i_r | - | Rapporto di riduzione richiesto | Reduction ratio required | Verlangtes Untersetungsverhältnis |
| K_t | - | Fattore di temperatura | Temperature factor | Temperaturfaktor |
| K_v | - | Fattore di velocità | Speed factor | Geschwindigkeitsfaktor |
| n_1 | min ⁻¹ | Velocità angolare in entrata | Angular input speed | Winkelgeschwindigkeit am Eingang |
| n_{1max} | min ⁻¹ | Velocità angolare massima in entrata | Maximum angular input speed | Max. Winkelgeschwindigkeit am Eingang |
| n_2 | min ⁻¹ | Velocità angolare in uscita | Angular output speed | Winkelgeschwindigkeit am Ausgang |
| n_{2r} | min ⁻¹ | Velocità angolare in uscita richiesta | Required angular output speed | Verlangte Winkelgeschwindigkeit am Ausgang |
| $n_{2r,eq}$ | min ⁻¹ | Velocità angolare in uscita equivalente | Equivalent angular output speed | Äquivalente Winkelgeschwindigkeit am Ausgang |
| P_1, P_2 | kW | Potenza in entrata/uscita | Input/output power | Leistung am Eingang/Ausgang |
| P_t | kW | Potenza termica | Thermal power | Wärmeleistung |
| P'_t | kW | Potenza termica corretta | Corrected thermal power | Korrigierte Wärmeleistung |
| q | l/min | Portata d'olio nel circuito ausiliario di raffreddamento | Oil flow rate in the auxiliary cooling circuit | Öldurchsatz im Hilfskühlkreislauf |
| $t_1, t_2 \dots t_i$ | - | Percentuale di durata dei livelli del ciclo di carico | Duration percentage of the loading cycle levels | Prozentuale Dauer der Stufen vom Lastzyklus |
| T_2 | Nm | Coppia in uscita trasmissibile | Transmissible output torque | Übertragbares Drehmoment am Ausgang |
| T_{2c} | Nm | Coppia in uscita corretta | Corrected output torque | Korrigiertes Drehmoment am Ausgang |
| T_{2max} | Nm | Coppia in uscita massima | Maximum output torque | Max. Drehmoment am Ausgang |
| T_{2n} | Nm | Coppia in uscita nominale | Nominal output torque | Nennndrehmoment am Ausgang |
| T_{2r} | Nm | Coppia in uscita richiesta | Required output torque | Verlangtes Drehmoment am Ausgang |
| $T_{2r,eq}$ | Nm | Coppia in uscita richiesta equivalente | Required equivalent output torque | Äquivalentes Drehmoment am Ausgang |
| T_F | Nm | Coppia frenante | Braking torque | Bremsdrehmoment |
| t_a | °C | Temperatura ambiente | Ambient temperature | Umgebungstemperatur |
| t_R | °C | Temperatura di funzionamento | Operating temperature | Betriebstemperatur |
| t_s | °C | Temperatura dell'olio in uscita dal circuito di raffreddamento | Temperature of the oil leaving the cooling circuit | Öltemperatur am Ausgang vom Kühlkreislauf |

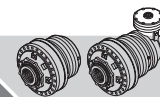

| Symbole Símbolo Símbolo | Unité de mesure Unidad de medida Unidade de medida | Description | Descripción | Descrição |
|-------------------------------|--|---|---|---|
| C_{rt} | - | Coefficient d'échange thermique | <i>Coefficiente de intercambio térmico</i> | Coeficiente de permutação térmica |
| $k_{r,1}, k_{r,2}$ | - | Coefficients de correction de la charge radiale à l'entrée/sortie | <i>Coefficientes correctores de la carga radial en entrada/salida</i> | Coeficientes corretivos da carga radial em entrada/saída |
| $f_{h,1}, f_{h,2}$ | - | Facteur de durée à l'entrée/sortie | <i>Factor de duración en entrada/salida</i> | Fator de duração em entrada/saída |
| $F_{r,1}, F_{r,2}$ | N | Charge radiale admissible sur l'arbre d'entrée/de sortie | <i>Carga radial admitida sobre el eje de entrada/salida</i> | Carga radial admissível no eixo de entrada/saída |
| $F_{a,2}$ | N | Charge axiale admissible sur l'arbre de sortie | <i>Carga axial admitida sobre el eje de salida</i> | Carga axial admissível no eixo de saída |
| f_s | - | Facteur de service | <i>Factor de servicio</i> | Fator de serviço |
| η | - | Rendement dynamique | <i>Rendimiento dinámico</i> | Rendimento dinâmico |
| h_r | h | Durée exigée | <i>Duración requerida</i> | Duração necessária |
| i | - | Rapport de réduction | <i>Relación de reducción</i> | Relação de redução |
| i_r | - | Rapport de réduction exigé | <i>Relación de reducción requerida</i> | Relação de redução necessária |
| K_t | - | Facteur de température | <i>Factor de temperatura</i> | Fator de temperatura |
| K_v | - | Facteur de vitesse | <i>Factor de velocidad</i> | Fator de velocidade |
| n_1 | min ⁻¹ | Vitesse angulaire à l'entrée | <i>Velocidad angular en entrada</i> | Velocidade angular em entrada |
| n_{1max} | min ⁻¹ | Vitesse angulaire maximum à l'entrée | <i>Velocidad angular máxima en entrada</i> | Velocidade angular máxima em entrada |
| n_2 | min ⁻¹ | Vitesse angulaire à la sortie | <i>Velocidad angular en salida</i> | Velocidade angular em saída |
| n_{2r} | min ⁻¹ | Vitesse angulaire à la sortie exigée | <i>Velocidad angular en salida requerida</i> | Velocidade angular em saída necessária |
| $n_{2r,eq}$ | min ⁻¹ | Vitesse angulaire à la sortie équivalente | <i>Velocidad angular en salida equivalente</i> | Velocidade angular em saída equivalente |
| P_1, P_2 | kW | Puissance à l'entrée/sortie | <i>Potencia en entrada/salida</i> | Potência em entrada/saída |
| P_t | kW | Puissance thermique | <i>Potencia térmica</i> | Potência térmica |
| P'_t | kW | Puissance thermique corrigée | <i>Potencia térmica corregida</i> | Potência térmica corrigida |
| q | l/min | Débit d'huile dans le circuit auxiliaire de refroidissement | <i>Caudal de aceite en el circuito auxiliar de refrigeración</i> | Caudal do óleo no circuito auxiliar de arrefecimento |
| $t_1, t_2 \dots$ t_i | - | Pourcentage de durée des niveaux du cycle de charge | <i>Porcentaje de duración de los niveles del ciclo de carga</i> | Percentagem de duração dos níveis do ciclo de carga |
| T_2 | Nm | Couple à la sortie transmissible | <i>Par en salida transmisible</i> | Par em saída transmissível |
| T_{2c} | Nm | Couple à la sortie corrigée | <i>Par en salida corregido</i> | Par em saída corrigido |
| T_{2max} | Nm | Couple à la sortie maximum | <i>Par en salida máximo</i> | Par em saída máximo |
| T_{2n} | Nm | Couple à la sortie nominal | <i>Par en salida nominal</i> | Par em saída nominal |
| T_{2r} | Nm | Couple à la sortie exigé | <i>Par en salida requerido</i> | Par em saída necessário |
| $T_{2r,eq}$ | Nm | Couple à la sortie exigé équivalent | <i>Par en salida requerido equivalente</i> | Par em saída necessário equivalente |
| T_F | Nm | Couple freinant | <i>Par de frenado</i> | Par de freio |
| t_a | °C | Température ambiante | <i>Temperatura ambiente</i> | Temperatura ambiente |
| t_R | °C | Température de fonctionnement | <i>Temperatura de funcionamiento</i> | Temperatura de funcionamento |
| t_s | °C | Température de l'huile à la sortie du circuit de refroidissement | <i>Temperatura del aceite en salida del circuito de refrigeración</i> | Temperatura do óleo em saída do circuito de arrefecimento |

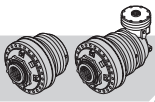

2 IDENTIFICAZIONE DEL PRODOTTO 2 PRODUCT IDENTIFICATION

2 PRODUKTKENNZEICHNUNG

2.1 Composizione di montaggio

2.1 Assembly layout

2.1 Montageaufbau

1. MOTORI
MOTORS
MOTOREN
MOTEURS
MOTOR
MOTOR

2. ENTRATE
INPUTS
EINGÄNGE
ENTREES
ENTRADAS
ENTRADAS

3. FRENI
BRAKES
BREMSEN
FREINS
FRENOS
FREIOS

4. GRUPPI RIDUZIONE
REDUCTION GEAR UNITS
UNTERSATZUNGSGETRIEBE
GROUPES DE REDUCTION
GRUPOS REDUCCIÓN
GRUPOS REDUÇÃO

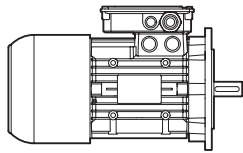

1.1 Motore elettrico
Electrical motor
Elektromotor
Moteur électrique
Motor eléctrico
Motor elétrico

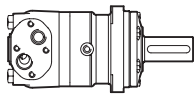

1.2 Motore idraulico
Hydraulic motor
Hydraulikmotor
Moteur hydraulique
Motor hidráulico
Motor hidráulico

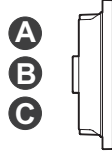

2.1 Entrata standard
Standard input
Standardeingang
Entrée standard
Entrada standard
Entrada padrão

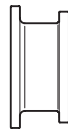

2.2 Accoppiamento motore elettrico
Electrical motor coupling
Kupplung Elektromotor
Accouplement moteur électrique
Acoplamiento motor eléctrico
Acoplagem motor elétrico

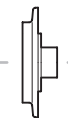

2.3 Accoppiamento motore idraulico
Hydraulic motor coupling
Kupplung Hydraulikmotor
Accouplement moteur hydraulique
Acoplamiento motor hidráulico
Acoplagem motor hidráulico

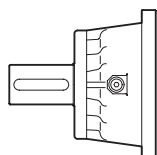

2.4 Entrata veloce
High-speed input
Schneller Eingang
Entrée rapide
Entrada rápida
Entrada rápida

3.1 Freno negativo
Negative brake
Negativbremse
Frein négatif
Freno negativo
Freio negativo

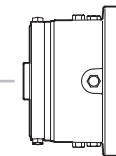

3.2 Freno negativo con accoppiamento per motore idraulico
Negative brake with hydraulic motor coupling
Negativbremse mit Kupplung für Hydraulikmotor
Frein négatif avec accouplement moteur hydraulique
Freno negativo con acoplamiento para motor hidráulico
Freio negativo com acoplagem para motor hidráulico

4.1 Stadio angolare
Angular stage
Winkelstufe
Etage angulaire
Etapa angular
Estádio angular

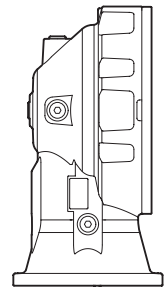

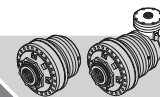

2 IDENTIFICATION DU PRODUIT

2 IDENTIFICACIÓN DEL PRODUCTO

2 IDENTIFICAÇÃO DO PRODUTO

2.1 Composition de montage

2.1 Composición de montaje

2.1 Composição de montagem

4. GRUPPI RIDUZIONE
REDUCTION GEAR UNITS
UNTERSETZUNGSGETRIEBE
GROUPES DE REDUCTION
GRUPOS REDUCCIÓN
GRUPOS REDUÇÃO

5. USCITE
OUTPUTS
AUSGÄNGE
SORTIES
SALIDAS
SAÍDAS

6. ALBERI
SHAFTS
WELLEN
ARBRES
EJES
EIXOS

7. ACCESSORI USCITA
OUTPUT ACCESSORIES
ZUBEHÖR AUSGANG
ACCESSOIRES SORTIE
ACCESORIOS SALIDA
ACESSÓRIOS SAÍDA

4.2 Stadio planetario
Planetary stage
Planetenstufe
Etage planétaire
Etapa planetario
Estádio planetário

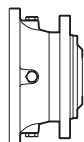
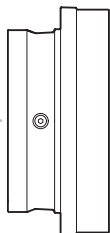

5.1 Uscita M
M Output
Ausgang M
Sortie M
Salida M
Saída M



5.2 Uscita B
B Output
Ausgang B
Sortie B
Salida B
Saída B

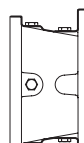

5.3 Uscita S
S Output
Ausgang S
Sortie S
Salida S
Saída S

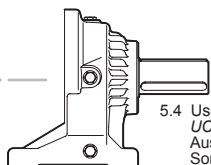

5.4 Uscita UC
UC Output
Ausgang UC
Sortie UC
Salida UC
Saída UC



5.5 Uscita FS
FS Output
Ausgang FS
Sortie FS
Salida FS
Saída FS

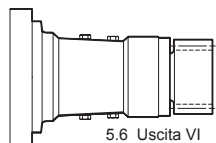

5.6 Uscita VI
VI Output
Ausgang VI
Sortie VI
Salida VI
Saída VI

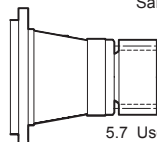

5.7 Uscita ZI
ZI Output
Ausgang ZI
Sortie ZI
Salida ZI
Saída ZI



S



C



H

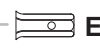

E



S



C



H



E

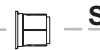

S



C



E

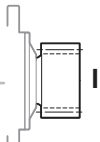

I



7.1 Flangia presa moto-tipo 28
Drive intake flange – type 28
Antriebsflansch – Typ 28
Bride prise mouvement – type 28
Brida toma movimiento – tipo 28
Flange tomada movimento – tipo 28



7.4 Flangetta di fissaggio-tipo 12
End plate – type 12
Befestigungsflansch – Typ 12
Bride de fixation – type 12
Brida de sujeción – tipo 12
Pequena flange de fixação – tipo 12



7.2 Boccola scanalata-tipo 29
Splined bush – type 29
Nutmuschse – Typ 29
Douille cannelée – type 29
Buje acanalado – tipo 29
Disco com ranhuras – tipo 29



7.3 Pignone-tipo 16
Pinion – type 16
Nutmuschse – Typ 16
Douille cannelée – type 16
Buje acanalado – tipo 16
Disco com ranhuras – tipo 16



7.5 Calettatore per attrito
Friction shrink disc
Schrumpfscheibe
Frette de serrage par frottement
Engargolador por fricción
Encaixador por atrito



7.6 Albero scanalato-tipo 27
Splined shaft – type 27
Keilwelle – Typ 27
Arbre cannelé – type 27
Eje acanalado – tipo 27
Veio com ranhuras – tipo 27

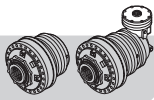

2.2 Designazione

I riduttori epicicloidali Reggiana Riduttori vengono identificati mediante una sigla composta nel seguente modo:

2.2 Designation

The Reggiana Riduttori planetary reduction gears are identified by an acronym made up in the following way:

2.2 Bezeichnung

Die Planetengetriebe von Reggiana Riduttori sind durch einen Code gekennzeichnet, der folgende Bedeutung hat:

RR 510 T FS 65.60 RF

**Configurazione ingresso (opzionale) / Input configuration (optional)
Konfiguration am Eingang (optional)**

- Ingresso standard / *Standard input* / Standardeingang
- RF** Predisposizione RF / *Setup RF* / Auslegung RF
- BOC** Predisposizione BOC / *Setup BOC* / Auslegung BOC

Rapporto di riduzione / Reduction ratio / Untersetzungsverhältnis

i = 3 - 3000

Tipo di uscita / Type of output / Typ Ausgang

- MS/BS** Maschio scanalato / *Male splined* / Zum Einstecken mit Nut
- MC/BC** Maschio cilindrico / *Male cylindrical* / Zum Einstecken zylindrisch
- MH/BH** Maschio cavo / *Male hollow* / Zum Einstecken hohl
- ME/BE** Maschio esagonale / *Male hexagonal* / Zum Einstecken sechseckig /
- SS** Rinforzato scanalato / *Splined reinforced* / Verstärkt mit Nut
- SC** Rinforzato cilindrico / *Cylindrical reinforced* / Verstärkt zylindrisch
- SE** Rinforzato esagonale / *Hexagonal reinforced* / Verstärkt sechseckig
- SI** Rinforzato con pignone integrale / *Reinforced with integral pinion* / Verstärkt mit integriertem Ritzel
- UC** Maschio cilindrico, con piedi / *Male cylindrical, with feet* / Zum Einstecken zylindrisch, mit Füßen
- FS** Femmina scanalato / *Female splined* / Zum Aufstecken mit Nut
- VI** Pignone integrale (doppio centraggio) / *Integral pinion (double centring)* / Integriertes Ritzel (doppelte Zentrierung)
- ZI** Pignone integrale (con flangia) / *Integral pinion (with flange)* / Integriertes Ritzel (mit Flansch)

Numero stadi / Number of stages / Anzahl Stufen

- Singolo stadio / *Single stage* / Einstufig
- D** Doppio stadio / *Double stage* / Zweistufig
- T** Triplo stadio / *Triple stage* / Dreistufig
- Q** Quadruplo stadio / *Quadruple stage* / Vierstufig

Grandezza / Size / Grösse

65, 105, 110, 210, 310, 510, 710, 810, 1010, 1700

Esecuzione

- RR** Riduttore lineare
- RA** Riduttore angolare

Nel caso sia possibile montare più di una grandezza di coppia conica in ingresso, le diverse alternative per le combinazioni risultanti si indicano con (A) e (B), a partire dall'alternativa con coppia conica più piccola.
Esempio: RA1700 (A), RA1700 (B).

*If it is possible to mount more than one bevel gear size in input, the different alternatives for the combinations are indicated with (A), (B) and (C) starting from the alternative with the smallest bevel gear.
Example: RA1700 (A), RA1700 (B).*

Falls mehrere Kegelpaargrößen am Eingang montiert werden können, werden die alternativen Kombinationen mit (A), (B) und (C) angegeben, ausgehend vom kleinsten Kegelpaar.
Beispiel: RA1700 (A), RA1700 (B).

2.3 Marcatura del prodotto e designazione del tipo

Tutti i prodotti Reggiana Riduttori sono dotati di targhetta di identificazione, posizionata in modo da risultare facilmente leggibile, anche dopo l'installazione.

La seguente figura mostra un esempio di targhetta.

2.3 Product marking and type designation

All Reggiana Riduttori products have an id plate positioned so as to be easily readable also after installation.

The following figure shows an example of a plate.

2.3 Produktkennzeichnung und Typschild

Alle Produkte von Reggiana Riduttori weisen ein Typenschild auf, das so angebracht ist, dass es auch nach der Installation leicht abgelesen werden kann.

Die Abbildung unten zeigt ein Beispi.

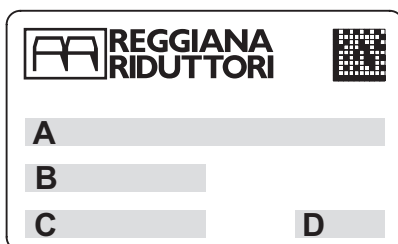

| | Legenda | Legend | Legende |
|----------|--------------------------------------|--------------------------------------|--|
| A | Tipo di riduttore e rapporto | <i>Reduction gear type and ratio</i> | Untersetzungstyp und Untersetzungsverhältnis |
| B | Codice identificativo di ordinazione | <i>ID code for ordering</i> | Identifizierungscode der Bestellung |
| C | N° progressivo di matricola | <i>Progressive serial number</i> | Fortlaufende Seriennummer |
| D | Mese/anno di produzione | <i>Months/year of production</i> | Monat/Baujahr |



2.2 Designation

Les réducteurs épicycloïdaux Reggiana Riduttori sont identifiés au moyen d'un sigle composé de la manière suivante:

2.2 Denominación

Los reductores epicicloidales Reggiana Riduttori están identificados por una sigla formada como sigue:

2.2 Designação

Os redutores epicicloidais Reggiana Riduttori são identificados mediante uma referência composta no seguinte modo:

| RR | 510 | T | FS | 65.60 | RF |
|--|-----|---|----|-------|----|
| <p>Configuración a l'entrèe (en option) / Configuración en entrada (opcional) Configuração em entrada (opcional)</p> <p>- Entrèe standard / <i>Entrada estándar</i> / Entrada padrão RF Préréglage RF / <i>Predisposición RF</i> / Predisposição RF BOC Préréglage BOC / <i>Predisposición BOC</i> / Predisposição BOC</p> | | | | | |
| <p>Rapport de réduction / Relación de reducción / Relação de redução $i = 3 - 3000$</p> | | | | | |
| <p>Type de sortie / Tipo de salida / Tipo de saída</p> <p>MS/BS Mâle cannelé / <i>Macho acanalado</i> / Macho com ranhuras MC/BC Mâle cylindrique / <i>Macho cilíndrico</i> / Macho cilíndrico MH/BH Mâle creux / <i>Macho hueco</i> / Macho ôco ME/BE Mâle hexagonal / <i>Macho hexagonal</i> / Macho hexagonal SS Renforcé cannelé / <i>Reforzado acanalado</i> / Reforçado com ranhuras SC Renforcé cylindrique / <i>Reforzado cilíndrico</i> / Reforçado cilíndrico SE Renforcé hexagonal / <i>Reforzado hexagonal</i> / Reforçado hexagonal SI Renforcé avec pignon intégral / <i>Reforzado con piñon integral</i> / Reforçado com pinhão integrado UC Mâle cylindrique avec pieds / <i>Macho cilíndrico, con patas</i> / Macho cilíndrico com pé FS Femelle cannelée / <i>Hembra acanalada</i> / Fêmea com ranhuras VI Pignon intégral (Double centrage) / <i>Piñon integral (doble centrado)</i> / Pinhão integrado (dupla centragem) ZI Pignon intégral (Avec bride) / <i>Piñon integral (con brida)</i> / Pinhão integrado (Com flange)</p> | | | | | |
| <p>Numero stadi / Number of stages / Anzahl Stufen</p> <p>— Simple étage / <i>Etapas individual</i> / Um estágio D Double étage / <i>Doble etapa</i> / Duplo estágio T Triple étage / <i>Triple etapa</i> / Triplo estágio Q Quadruple étage / <i>Cuádruple etapa</i> / Quadruplo estágio</p> | | | | | |
| <p>Grandezza / Size / Grösse 65, 105, 110, 210, 310, 510, 710, 810, 1010, 1700</p> | | | | | |
| <p>Esecuzione</p> <p>RR Riduttore lineare RA Riduttore angolare</p> | | | | | |

Si'il est possible de monter plus d'une grandeur de couple conique à l'entrée, les différentes alternatives pour les combinaisons possibles sont indiquées par les lettres (A), (B) et (C), à partir de l'alternative avec un couple conique plus petit.

Exemple: RA1700 (A), RA1700 (B).

Si fuese posible montar más de una talla de par cónico en entrada, las diferentes alternativas para las combinaciones resultante se indican con (A), (B) y (C), a partir de la alternativa con par cónico más pequeño.

Ejemplo: RA1700 (A), RA1700 (B).

No caso em que seja possível montar mais do que uma grandeza de par cónico em entrada, as várias alternativas para as combinações que resultam são indicadas com (A), (B) e (C), a partir da alternativa com par cónico mais pequeno.

Exemplo: RA1700 (A), RA1700 (B).

2.3 Marquage du produit et désignation du type

Sur tous les produits Reggiana Riduttori, une plaquette d'identification est appliquée. Elle est positionnée de manière à être facile à lire, même une fois le réducteur installé.

La figure suivante montre un exemple de la plaquette.

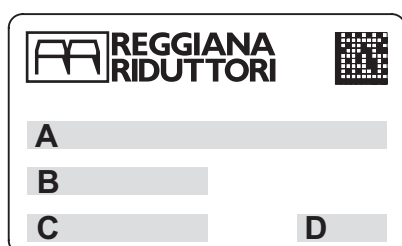

2.3 Marcado del producto y denominación del tipo

Todos los productos Reggiana Riduttori llevan una placa de identificación, colocada de manera que resulte fácilmente legible, también después de la instalación.

La siguiente figura presenta un ejemplo de placa.

2.3 Marcação do produto e designação do tipo

Todos os produtos Reggiana Riduttori são munidos de placa de identificação, colocada de modo a ser lida com facilidade, também depois da instalação.

A seguinte figura ilustra um exemplo de placa.

| | Légende | Leyenda | Legenda |
|----------|---|---|---------------------------------------|
| A | Type de réducteur et rapport de réduction | <i>Tipo de reductor y relación de reducción</i> | Tipo de reductor e relação de redução |
| B | Code d'identification de la commande | <i>Código identificador de pedido</i> | Código identificativo de encomenda |
| C | N° progressif de série | <i>N° progresivo de matrícula</i> | N° progressivo de matrícula |
| D | Mois/année de fabrication | <i>Mes/año de producción</i> | Mês/ano de produção |

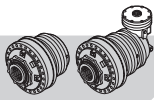

3 CARATTERISTICHE TECNICHE

3.1 Funzioni generali, gamma di applicazioni e utilizzo previsto

I riduttori epicicloidali Reggiana Riduttori sono progettati per realizzare la trasmissione di potenza all'interno di macchine operatrici. Essi possono essere collegati direttamente o indirettamente ad un motore di tipo elettrico o idraulico.

I riduttori epicicloidali vengono utilizzati nell'ambito di diverse applicazioni, sia industriali che mobili, tra le quali: industria meccanica, industria chimica e plastica, industria alimentare, edilizia e costruzioni, industria estrattiva, agricoltura e foreste, trasporti e sollevamento, settore marino, generatori eolici di energia.

3 TECHNICAL CHARACTERISTICS

3.1 General functions, range of applications and intended use

The Reggiana Riduttori planetary reduction gears are designed for transmitting power inside operating machines. They can be connected directly or indirectly to either an electric or hydraulic motor.

The planetary reduction gears are used for many different types of application, both industrial and mobile some of which are: the mechanical industry, the chemical and plastics industry, the food industry, building and constructions, mining industry, agriculture and forestry, transporting and lifting, marine sector, wind generators of energy.

3 TECHNISCHE BESCHREIBUNG

3.1 Allgemeine Funktionen, Anwendungsbereiche und vorgesehene Anwendung

Die Planetengetriebe von Reggiana Riduttori werden für die Leistungsübertragung im Inneren von Arbeitsmaschinen konzipiert und gefertigt. Sie können direkt oder indirekt an einen Elektromotor oder einen Hydraulikmotor angeschlossen werden.

Die Planetengetriebe werden sowohl in der Industrie, als auch im Fahrzeugbau in verschiedenen Anwendungen eingesetzt, darunter: Maschinenbau, chemische und Kunststoff verarbeitende Industrie, Lebensmittelindustrie, Bauwirtschaft, Bergbau, Land- und Forstwirtschaft, Transport- und Hubtechnik, Schiffbau, Windkraftanlagen.



Utilizzare il riduttore soltanto per gli usi previsti in fase di progetto. L'impiego per usi impropri può essere causa di pericolo per la sicurezza e la salute delle persone. Gli usi previsti sono quelli industriali e mobili per i quali sono stati sviluppati e costruiti i riduttori.

Use the reduction gear only for the uses contemplated in the project phase. Using it improperly can be the cause of danger for the safety and health of people. The reductions gears have been designed and made for industrial and mobile uses.

Die Planetengetriebe dürfen nur für den vom Hersteller vorgesehenen Zweck verwendet werden. Bei unsachgemäßem Gebrauch kann die Sicherheit und Gesundheit von Personen gefährdet werden. Unter vorgesehenem Gebrauch werden die industriellen und mobilen Anwendungen verstanden, für die die Planetengetriebe entwickelt und gebaut worden sind.

3.2 Coppia in uscita nominale

T_{2n} [Nm]

È un valore di coppia caratteristico di ciascuna grandezza di riduttore, utile per una selezione di massima della grandezza del riduttore. Fare riferimento alla tabella presente all'inizio della sezione relativa ai dati tecnici.

3.2 Nominal output torque

T_{2n} [Nm]

It is a torque value characteristic of each reduction gear size, useful for a general selection of the size of the reduction gear. Please refer to the table at the beginning of the technical data section.

3.2 Nominales Ausgangsdrehmoment

T_{2n} [Nm]

Dabei handelt es sich um das charakteristische Drehmoment jeder Untersetzungsgröße, das bei der Auswahl der Größe des Planetengetriebes hilfreich ist. Bitte die Tabelle am Anfang der technischen Daten beachten.

3.3 Coppia in uscita

T_2 [Nm]

È il valore di coppia trasmissibile, in funzionamento continuo e uniforme con fattore di servizio $f_s=1$, per un dato valore del fattore di durata f_h . I valori di T_2 , calcolati per alcuni valori del fattore di durata f_h , sono riportati nella tabella dei dati tecnici posta all'inizio della sezione relativa ad ogni grandezza di riduttore.

La coppia T_2 è limitata dalla resistenza a flessione o dalla resistenza superficiale dei denti degli ingranaggi, in accordo con la norma ISO 6336, ovvero dalla resistenza dei cuscinetti, in accordo con la norma ISO 281.

3.3 Output torque

T_2 [Nm]

It is the transmissible torque value in continuous and uniform operation with a service factor $f_s=1$ for a given value of the duration factor f_h . The T_2 values, calculated for some values of the duration factor f_h , are given in the technical data table at the beginning of the section relative to each reduction gear size.

T_2 torque is limited to the bending strength or the surface strength of the gear teeth, in agreement with the ISO 6336 standard, or bearing strength, in agreement with the ISO 281 standard.

3.3 Ausgangsdrehmoment

T_2 [Nm]

Dabei handelt es sich um den Wert vom übertragbaren Drehmoment bei gleichmäßigem Dauerbetrieb mit Betriebsfaktor $f_s=1$ für einen gegebenen Wert vom Zeitfaktor f_h . Die Werte von T_2 , die für einige Werte vom Zeitfaktor f_h berechnet worden sind, sind in der Tabelle mit den technischen Daten am Anfang vom Abschnitt der jeweiligen Untersetzungsgröße angegeben. Das Drehmoment T_2 wird von der Biegefestigkeit oder dem Oberflächenwiderstand der Zähne vom Getriebe nach Vorgabe der Norm ISO 6336 beschränkt, oder von der Widerstandsfähigkeit der Lager nach Vorgabe der Norm ISO 281.

3.4 Coppia in uscita massima

T_{2max} [Nm]

Rappresenta il valore di coppia massima applicabile in uscita al riduttore per brevi durate o per picchi occasionali, senza il verificarsi di danneggiamenti permanenti agli elementi più sollecitati.

3.4 Maximum output torque

T_{2max} [Nm]

It is the maximum torque value applicable in reduction gear output for short lengths of time or for occasional peaks, without any permanent damage to the most stressed elements.

3.4 Maximales Ausgangsdrehmoment

T_{2max} [Nm]

Dabei handelt es sich um den Wert vom Drehmoment, das maximal am Ausgang des Planetengetriebes für kurze Zeit oder gelegentliche Spitzen angelegt werden kann, ohne dass dies zu einer dauerhaften Schädigung der am stärksten Belasteten Bauteile führt.



3 CARACTERISTIQUES TECHNIQUES

3.1 Fonctions générales, gamme d'applications et utilisation prévue

Les réducteurs épicycloïdaux Reggiana Riduttori sont projetés pour réaliser la transmission de puissance dans des engins de travaux publics. Ils peuvent être raccordés directement ou indirectement à un moteur de type électrique ou hydraulique. Les réducteurs épicycloïdaux sont utilisés dans le cadre de plusieurs applications, aussi bien dans le domaine industriel que mobile, parmi lesquelles: l'industrie mécanique, l'industrie chimique et plastique, l'industrie alimentaire, le bâtiment et les constructions, l'industrie extractive, l'agriculture et la sylviculture, le transport et les systèmes de levage, la marine, les générateurs éoliens.



N'utiliser le réducteur que pour les usages pour lesquels il a été projeté. Son utilisation impropre peut être cause de danger pour la sécurité et la santé des personnes.

Les usages prévus sont les emplois industriels et mobiles pour lesquels les réducteurs ont été élaborés et fabriqués.

3.2 Couple à la sortie nominale

T_{2n} [Nm]

Il s'agit d'une valeur de couple caractéristique de chaque grandeur de réducteur, utile à une sélection de principe de la grandeur du réducteur. Se rapporter au tableau se trouvant au début de la section relative aux caractéristiques techniques.

3.3 Couple à la sortie

T_2 [Nm]

Il s'agit de la valeur de couple transmissible, en service continu et uniforme avec facteur de service $f_s=1$, pour une valeur du facteur de durée donnée f_h . Les valeurs de T_2 , calculées pour certaines valeurs du facteur de durée f_h , sont indiquées sur le tableau des caractéristiques techniques se trouvant au début de la section relative à chaque grandeur de réducteur.

Le couple T_2 est limité par la résistance à la flexion et par la résistance superficielle des dents des engrenages, conformément à la norme ISO 6336, c'est-à-dire par la résistance des roulements, conformément à la norme ISO 281.

3.4 Couple à la sortie maximum

T_{2max} [Nm]

Il représente la valeur de couple maximum applicable à la sortie au réducteur pour de courtes durées ou pour des pics occasionnels, sans provoquer de dommages permanents aux éléments les plus sollicités.

3 CARACTERÍSTICAS TÉCNICAS

3.1 Funciones generales, gama de aplicaciones y uso previsto

Los reductores epicicloidales Reggiana Riduttori están proyectados para realizar la transmisión de potencia dentro de máquinas operadoras. Se pueden acoplar directamente o indirectamente con un motor de tipo eléctrico o hidráulico.

Los reductores epicicloidales se utilizan en el ámbito de distintas aplicaciones, tanto industriales como móviles, entre las cuales: industria mecánica, industria química y del plástico, industria alimentaria, de la construcción, industria minera, agricultura y forestal, transportes y elevación, sector marítimo, generadores eólicos de energía.

Utilizar el reductor sólo para los usos previstos en la fase de proyecto. La utilización para usos no adecuados puede causar peligro para la seguridad y la salud de las personas.

Los usos previstos son aquellos industriales y móviles para los cuales han sido desarrollados y construidos los reductores.

3.2 Par en salida nominal

T_{2n} [Nm]

Es un valor de par característico de cada talla de reductor, útil para una selección aproximada de la talla del reductor. Hágase referencia a la tabla presentada al inicio de la sección referente a los datos técnicos.

3.3 Par en salida

T_2 [Nm]

Es el valor de par transmisible, en funcionamiento continuo y uniforme con factor de servicio $f_s=1$, para un dado valor del factor de duración f_h . Los valores de T_2 , calculados para algunos valores del factor de duración f_h , se indican en la tabla de los datos técnicos presentada al inicio de la sección referente a cada talla de reductor.

El par T_2 está limitado por la resistencia a la flexión o por la resistencia superficial de los dientes de los engranajes, según la norma ISO 6336, o bien por la resistencia de los cojinetes, según la norma ISO 281.

3.4 Par en salida máximo

T_{2max} [Nm]

Representa el valor de par máximo aplicable en salida al reductor por breves duraciones o por picos ocasionales, sin que se produzcan daños permanentes a los elementos mayormente bajo esfuerzo.

3 CARACTERÍSTICAS TÉCNICAS

3.1 Funções gerais, gama de aplicações e emprego previsto

Os redutores epicicloidais Reggiana Riduttori foram concebidos para realizar a transmissão de potência no interior de máquinas operadoras. Os mesmos podem ser ligados direta ou indiretamente a um motor de tipo elétrico ou hidráulico.

Os redutores epicicloidais são empregues no âmbito de várias aplicações, quer industriais quer móveis, entre as quais: indústria mecânica, indústria química e dos plásticos, indústria alimentar, construção civil, indústria mineirária, agricultura e florestas, transportes e levantamento, setor marítimo, geradores eólicos de energia.

Usar o reductor exclusivamente para os usos previstos na fase de projeto. O emprego em usos impróprios pode ser causa de perigo para a segurança e a saúde das pessoas.

Os usos previstos são aqueles industriais e móveis para os quais os redutores foram concebidos e construídos.

3.2 Par em saída nominal

T_{2n} [Nm]

É um valor de par característico de cada uma das grandezas do reductor, útil para uma seleção aproximada da grandeza do reductor. Consultar a tabela presente no início da seção relativa aos dados técnicos.

3.3 Par em saída

T_2 [Nm]

É o valor de par transmissível, em funcionamento contínuo e uniforme com fator de serviço $f_s=1$, para um determinado valor do fator de duração f_h . Os valores de T_2 , calculados para alguns valores do fator de duração f_h , estão indicados na tabela dos dados técnicos que se encontra no início da seção relativa a cada grandeza do reductor.

O par T_2 é limitado pela resistência à flexão ou pela resistência superficial dos dentes das engrenagens, de acordo com a norma ISO 6336, ou pela resistência dos rolamentos, de acordo com a norma ISO 281.

3.4 Par em saída máximo

T_{2max} [Nm]

Representa o valor de par máximo aplicável em saída ao reductor por breves períodos ou por picos ocasionais, sem que se verifiquem danos permanentes nos elementos mais solicitados.

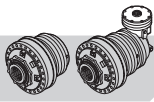

In presenza di un carico radiale, la coppia massima applicabile subisce una diminuzione.

In the case of a radial load the maximum applicable torque is reduced.

Bei Vorhandensein einer Querlast verringert sich das maximal anlegbare Drehmoment.

3.5 Coppia in uscita richiesta

$$T_{2r} \text{ [Nm]}$$

È il valore di coppia in uscita che si intende applicare al riduttore, in base ai dati di funzionamento dell'applicazione.

3.5 Required output torque

$$T_{2r} \text{ [Nm]}$$

It is the value of output torque one intends applying to the reduction gear based on the operating data of the application.

3.5 Verlangtes Ausgangsdrehmoment

$$T_{2r} \text{ [Nm]}$$

Dabei handelt es sich um den Wert vom Ausgangsdrehmoment, das an das Planetengetriebe angelegt werden soll. Der Wert basiert auf den Funktionsdaten der Anwendung.

3.6 Coppia in uscita corretta

$$T_{2c} \text{ [Nm]}$$

Si calcola in base alla coppia richiesta e al fattore di servizio ed è il valore in base al quale si seleziona il riduttore idoneo per una data applicazione.

3.6 Corrected output torque

$$T_{2c} \text{ [Nm]}$$

It is calculated on the basis of the torque required and on the service factor and is the value on the basis of which the reduction gear is chosen suitable for a given application.

3.6 Korrigiertes Ausgangsdrehmoment

$$T_{2c} \text{ [Nm]}$$

Dieser Wert wird aus dem verlangten Ausgangsdrehmoment und dem Betriebsfaktor errechnet und stellt den Ausgangswert für die Auswahl der Untersezung dar, die sich für die jeweilige Anwendung eignet.

3.7 Velocità in entrata

$$n_1 \text{ [min}^{-1}\text{]}$$

È la velocità del motore collegato in ingresso al riduttore o, nel caso di collegamento indiretto, dell'albero di entrata del riduttore.

3.7 Input speed

$$n_1 \text{ [min}^{-1}\text{]}$$

It is the speed of the motor connected to the reduction gear input or, in the case of an indirect connection, of the reduction gear's input shaft.

3.7 Eingangsgeschwindigkeit

$$n_1 \text{ [min}^{-1}\text{]}$$

Dabei handelt es sich um die Geschwindigkeit vom Motor, der am Eingang vom Planetengetriebe angeschlossen ist, oder, bei indirektem Anschluss, von der Eingangswelle des Planetengetriebes.

3.8 Velocità in uscita

$$n_2 \text{ [min}^{-1}\text{]}$$

È la velocità dell'albero di uscita del riduttore, funzione della velocità in entrata n_1 e del rapporto di riduzione effettivo i .

3.8 Output speed

$$n_2 \text{ [min}^{-1}\text{]}$$

It is the speed of the reduction gear's output shaft, as a function of the input speed n_1 and of the actual reduction ratio i .

3.8 Ausgangsgeschwindigkeit

$$n_2 \text{ [min}^{-1}\text{]}$$

Dabei handelt es sich um die Geschwindigkeit der Ausgangswelle vom Planetengetriebe, die sich aus der Eingangsgeschwindigkeit n_1 und dem effektiven Unterseetzungsverhältnis i ergibt.

3.9 Rapporto di riduzione

$$i$$

Indica l'effettivo rapporto tra la velocità in entrata n_1 e la velocità in uscita n_2 del riduttore:

3.9 Reduction ratio

$$i$$

It indicates the actual ratio between the reduction gear's input speed n_1 and output speed n_2 :

3.9 Unterseetzungsverhältnis

$$i$$

Dabei handelt es sich um das effektive Verhältnis von Eingangsgeschwindigkeit n_1 zu Ausgangsgeschwindigkeit n_2 vom Planetengetriebe:

$$i = \frac{n_1}{n_2}$$

I rapporti di riduzione disponibili sono riportati nella tabella dei dati tecnici per ogni grandezza di riduttore. Su richiesta è possibile ottenere ulteriori rapporti di riduzione.

The reduction ratios available are given in the technical data table for each reduction gear size. Other reduction ratios can be obtained on request.

Die verfügbaren Unterseetzungsverhältnisse sind für jede Größe vom Planetengetriebe in der Tabelle mit den technischen Daten zusammengestellt. Auf Wunsch sind weitere Unterseetzungsverhältnisse erhältlich.

3.10 Velocità in entrata massima

$$n_{1max} \text{ [min}^{-1}\text{]}$$

Indica la velocità massima ammessa in entrata per brevi durate o in funzionamento intermittente; la velocità in entrata del riduttore è limitata dalla velocità periferica degli ingranaggi, dai cuscinetti e dalle tenute.

3.10 Maximum input speed

$$n_{1max} \text{ [min}^{-1}\text{]}$$

It indicates the maximum permitted input speed for short lengths of time or intermittently; the reduction gear's input speed is limited by the peripheral speed of the gears, by the bearings and by the seals.

3.10 Maximale Eingangsgeschwindigkeit

$$n_{1max} \text{ [min}^{-1}\text{]}$$

Dabei handelt es sich um die maximal zulässige Eingangsgeschwindigkeit für kurze Dauer oder bei unterbrochenem Betrieb. Die Eingangsgeschwindigkeit vom Planetengetriebe ist durch die Peripheriegeschwindigkeit von Zahnrädern, Lagern und Dichtungen beschränkt.

3.11 Senso di rotazione

3.11 Rotation direction

3.11 Rotationsrichtung

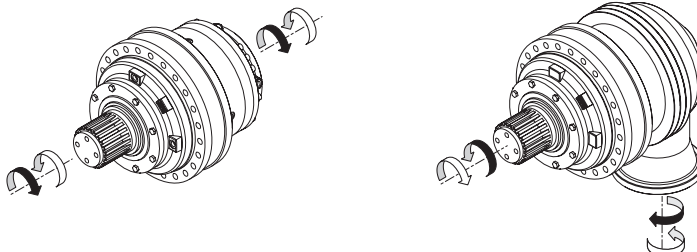

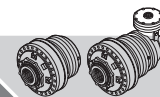

En présence d'une charge radiale, le couple maximum applicable subit une diminution.

En presencia de una carga radial, el par máximo aplicable sufre una disminución.

Em presença de uma carga radial, o par máximo aplicável sofre uma diminuição.

3.5 Couple à la sortie exigé

T_{2r} [Nm]

Il s'agit de la valeur de couple à la sortie qu'on veut appliquer au réducteur, sur la base des caractéristiques d'opération de l'application.

3.5 Par en salida requerido

T_{2r} [Nm]

Es el valor de par en salida que se desea aplicar al reductor, sobre la base de los datos de funcionamiento de la aplicación.

3.5 Par em saída necessário

T_{2r} [Nm]

É o valor de par em saída que se deseja aplicar ao redutor, segundo os dados de funcionamento da aplicação.

3.6 Couple à la sortie corrigé

T_{2c} [Nm]

Il est calculé sur la base du couple exigé et du facteur de service et c'est la valeur en fonction de laquelle on choisit le réducteur le plus approprié à une application donnée.

3.6 Par en salida corregido

T_{2c} [Nm]

Se calcula sobre la base del par requerido y del factor de servicio y es el valor sobre la base del cual se selecciona el reductor idóneo para una determinada aplicación.

3.6 Par em saída corrigido

T_{2c} [Nm]

É calculado segundo o par necessário e o fator de serviço, sendo o valor segundo o qual se selecciona o redutor idóneo para uma determinada aplicação.

3.7 Vitesse à l'entrée

n_1 [min^{-1}]

Il s'agit de la vitesse du moteur relié à l'entrée au réducteur ou, dans le cas de connexion indirecte, de l'arbre d'entrée du réducteur.

3.7 Velocidad en entrada

n_1 [min^{-1}]

Es la velocidad del motor conectado a la entrada del reductor o, en el caso de conexión indirecta, del eje de entrada del reductor.

3.7 Velocidade em entrada

n_1 [min^{-1}]

É a velocidade do motor ligado à entrada do redutor ou, no caso de ligação indireta, do veio de entrada do redutor.

3.8 Vitesse à la sortie

n_2 [min^{-1}]

Il s'agit de la vitesse de l'arbre de sortie du réducteur, en fonction de la vitesse à l'entrée n_1 et du rapport de réduction effectif i .

3.8 Velocidad en salida

n_2 [min^{-1}]

Es la velocidad del eje de salida del reductor, función de la velocidad en entrada n_1 y de la relación de reducción efectiva i .

3.8 Velocidade em saída

n_2 [min^{-1}]

É a velocidade do veio de saída do redutor, função da velocidade em entrada n_1 e da relação de redução efetiva i .

3.9 Rapport de réduction

i

Il indique le rapport effectif entre la vitesse à l'entrée n_1 et la vitesse à la sortie n_2 du réducteur:

3.9 Relación de reducción

i

Indica la efectiva relación entre la velocidad en entrada n_1 y la velocidad en salida n_2 del reductor:

3.9 Relação de redução

i

Indica a efetiva relação entre a velocidade em entrada n_1 e a velocidade em saída n_2 do redutor:

$$i = \frac{n_1}{n_2}$$

Les rapports de réduction existants sont indiqués dans le tableau des caractéristiques techniques pour chaque grandeur de réducteur. Sur demande, il est possible d'obtenir des rapports de réduction supplémentaires.

Las relaciones de reducción disponibles se indican en la tabla de los datos técnicos para cada talla de reductor. Bajo demanda es posible obtener ulteriores relaciones de reducción.

As relações de redução disponíveis estão indicadas na tabela dos dados técnicos para cada grandeza de redutor. A pedido, é possível obter outras relações de redução.

3.10 Vitesse à l'entrée maximum

$n_{1\text{max}}$ [min^{-1}]

Elle indique la vitesse maximum admise à l'entrée pour de courtes durées ou en fonctionnement intermittent; la vitesse à l'entrée du réducteur est limitée par la vitesse périphérique des engrenages, par les roulements et les garnitures.

3.10 Velocidad en entrada máxima

$n_{1\text{max}}$ [min^{-1}]

Indica la velocidad máxima admitida en entrada por breves duraciones o en funcionamiento intermitente; la velocidad en entrada del reductor está limitada por la velocidad periférica de los engranajes, por los cojinetes y por las estanqueidades.

3.10 Velocidade em entrada máxima

$n_{1\text{max}}$ [min^{-1}]

Indica a velocidade máxima admitida em entrada por breves períodos ou em funcionamento intermitente; a velocidade em entrada do redutor é limitada pela velocidade periférica das engrenagens, pelos rolamentos e pelas vedações.

3.11 Sens de rotation

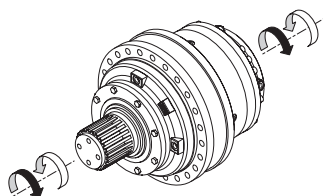

3.11 Sentido de giro

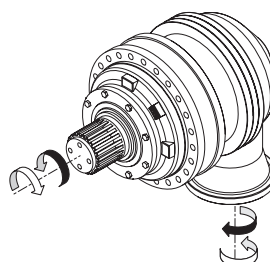

3.11 Direcção de rotação

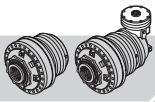
**3.11 Fattore di durata in entrata/uscita** $f_{h,1}, f_{h,2}$

È il prodotto della velocità in entrata/uscita per la durata richiesta:

3.11 Input/output duration factor $f_{h,1}, f_{h,2}$

It is the product of the input/output speed for the duration required:

3.11 Zeitfaktor Eingang/Ausgang $f_{h,1}, f_{h,2}$

Dabei handelt es sich um das Produkt aus der Eingang-/Ausgangsgeschwindigkeit und der verlangten Zeitdauer:

$$f_{h,1} = n_1 \cdot h_r$$

$$f_{h,2} = n_2 \cdot h_r$$

3.12 Potenza in entrata P_1 [kW]

È la potenza applicata in ingresso al riduttore, mediante collegamento diretto o indiretto (con ulteriori organi di trasmissione) di un motore.

3.12 Input power P_1 [kW]

It is the power applied in input to the reduction gear by either a direct or indirect connection (with additional transmission parts) of a motor.

3.12 Eingangsleistung P_1 [kW]

Dabei handelt es sich um die Leistung, die am Eingang vom Planetengetriebe über einen direkt oder indirekt (mit weiteren Übertragungsorganen) angeschlossenen Motor anliegt.

3.13 Potenza in uscita P_2 [kW]

È la potenza richiesta dall'utilizzatore collegato in uscita al riduttore. Si può calcolare come:

3.13 Output power P_2 [kW]

It is the power required by the user connected in output to the reduction gear. It can be calculated as:

3.13 Ausgangsleistung P_2 [kW]

Dabei handelt es sich um die vom Abnehmer verlangte Leistung, der am Ausgang vom Planetengetriebe angeschlossen ist. Die Ausgangsleistung wird wie folgt berechnet:

$$P_2 = \frac{T_{2r} \cdot n_2}{9550}$$

3.14 Rendimento η

È un coefficiente adimensionale dato dal rapporto tra la potenza in uscita P_2 e quella in entrata P_1 :

3.14 Efficiency η

It is a dimensionless coefficient given by the ratio between the output power P_2 and input power P_1 :

3.14 Wirkungsgrad η

Dabei handelt es sich um einen dimensionslosen Wert, der sich aus dem Verhältnis der Ausgangsleistung P_2 zur Eingangsleistung P_1 ergibt:

$$\eta = \frac{P_2}{P_1}$$

Il valore di rendimento di un singolo stadio di riduzione, in condizioni medie di velocità e coppia, è pari a 0.975; tale valore decresce nel caso di: incremento della velocità, diminuzione della coppia trasmessa, aumento della temperatura ambiente. Gli stadi angolari, di norma, sono caratterizzati da valori inferiori di rendimento.

The efficiency value of a single reduction stage under average speed and torque conditions, is equivalent to 0.975; this value decreases if: speed decreases, transmitted torque diminishes, ambient temperature increases. As a rule angular stages are characterised by inferior efficiency values.

Der Wert vom Wirkungsgrad einer einzelnen Untersetzungsstufe bei mittlerer Geschwindigkeit und Drehmoment entspricht 0.975. Dieser Wert nimmt bei zunehmender Geschwindigkeit, abnehmendem anliegendem Drehmoment und zunehmender Umgebungstemperatur ab. Die Winkelstufen sind in der Regel durch niedrigere Wirkungsgrade gekennzeichnet.

3.15 Fattore di servizio f_s

È un coefficiente moltiplicativo della coppia richiesta in uscita al riduttore, che tiene conto del tipo di servizio, della frequenza di avviamento e del numero di ore di funzionamento giornaliero.

In base alla macchina su cui va applicato il riduttore, si individua dalla tabella della classificazione delle applicazioni il tipo di servizio (uniforme, moderato o pesante). Successivamente si ottiene il valore del fattore di servizio dalla apposita tabella.

3.15 Service factor f_s

It is a multiplicative coefficient of the torque required in output from the reduction gear and takes into account the type of duty, start-up frequency and the number of hours of operation per day.

Depending on the machine the reduction gear is going to be mounted on, the type of service (uniform, moderate or heavy) can be found in the application classification table. You can then find the service factor from the relative table.

3.15 Betriebsfaktor f_s

Dabei handelt es sich um einen Multiplikationskoeffizienten des am Ausgang vom Planetengetriebe verlangten Drehmoment, der die Art vom Betrieb, die Startfrequenz und die Betriebsstunden pro Tag berücksichtigt.

Anhand der Maschine, in die das Planetengetriebe installiert wird, kann der Tabelle mit der Klassifikation der Anwendungen die Art vom Betrieb entnommen werden (gleichmäßig [u], gemäßig [m] und schwer [h]). Aus der entsprechenden Tabelle kann anschließend der Betriebsfaktor entnommen werden.



3.11 Facteur de durée à l'entrée/sortie $f_{h,1}, f_{h,2}$

Il s'agit du produit de la vitesse à l'entrée/sortie pour la durée exigée:

3.11 Factor de duración en entrada/salida $f_{h,1}, f_{h,2}$

Es el producto de la velocidad en entrada/salida por la duración requerida:

3.11 Fator de duração em entrada/saída $f_{h,1}, f_{h,2}$

É o produto da velocidade em entrada/saída pela duração necessária:

$$f_{h,1} = n_1 \cdot h_r \quad f_{h,2} = n_2 \cdot h_r$$

3.12 Puissance à l'entrée P_1 [kW]

Il s'agit de la puissance appliquée à l'entrée au réducteur, par la connexion directe ou indirecte (par le biais d'organes de transmission supplémentaires) d'un moteur.

3.12 Potencia en entrada P_1 [kW]

Es la potencia aplicada en entrada al reductor, mediante conexión directa o indirecta (con ulteriores órganos de transmisión) de un motor.

3.12 Potência em entrada P_1 [kW]

É a potência aplicada em entrada no reductor, mediante ligação direta ou indireta (com outros órgãos de transmissão) de um motor.

3.13 Puissance à la sortie P_2 [kW]

Il s'agit de la puissance exigée par l'utilisateur relié à la sortie du réducteur, qu'on peut calculer de la manière suivante:

3.13 Potencia en salida P_2 [kW]

Es la potencia requerida por el aparato usuario conectado con la salida del reductor. Se puede calcular como:

3.13 Potência em saída P_2 [kW]

É a potência requerida pelo usuário ligado em saída ao reductor. Pode ser calculada como:

$$P_2 = \frac{T_{2r} \cdot n_2}{9550}$$

3.14 Rendement η

Le rendement est un nombre adimensionnel, défini comme le rapport entre la puissance à la sortie P_2 et la puissance à l'entrée P_1 du réducteur:

3.14 Rendimiento η

Es un coeficiente adimensional dado por la relación entre la potencia en salida P_2 y aquella en entrada P_1 :

3.14 Rendimento η

É um número coeficiente dado pela relação entre a potência em saída P_2 e aquela em entrada P_1 :

$$\eta = \frac{P_2}{P_1}$$

La valeur du rendement d'un seul étage de réduction, dans des conditions moyennes de vitesse et de couple, équivaut à 0.975. Cette valeur décroît dans les cas suivants: augmentation de la vitesse, diminution du couple transmis, augmentation de la température ambiante. Les étages angulaires sont généralement caractérisés par des valeurs inférieures de rendement.

El valor de rendimiento de una etapa individual de reducción, en condiciones medias de velocidad y par, vale 0.975; dicho valor disminuye en caso de: aumento de la velocidad, disminución del par transmitido, aumento de la temperatura ambiente. Las etapas angulares, normalmente, se caracterizan por valores inferiores de rendimiento.

O valor de rendimento de apenas um estágio de redução, em condições médias de velocidade e par, é equivalente a 0.975; este valor decresce no caso de: incremento da velocidade, diminuição do par transmitido, aumento da temperatura ambiente. Os estádios angulares, geralmente, são caracterizados por valores inferiores de rendimento.

3.15 Facteur de service f_s

Il s'agit d'un coefficient multiplicatif du couple exigé à la sortie du réducteur, qui tient compte du type de service, de la cadence de démarrages et de la quantité d'heures de fonctionnement par jour. Suivant la machine sur laquelle le réducteur doit être appliqué, on peut trouver dans le tableau de la classification des applications, le type de service (uniforme, modéré ou lourd). Ensuite on obtient la valeur du facteur de service dans le tableau correspondant.

3.15 Factor de servicio f_s

Es un coeficiente multiplicador del par requerido en salida del reductor, que tiene en cuenta el tipo de servicio, la frecuencia de arranques y el número diario de horas de funcionamiento. Según la máquina en la cual se aplica el reductor, se individúa en la tabla de la clasificación de las aplicaciones el tipo de servicio (uniforme, moderado o pesado). Sucesivamente, se obtiene el valor del factor de servicio en la tabla correspondiente.

3.15 Fator de serviço f_s

É um coeficiente multiplicativo do par necessário em saída do reductor, que toma em consideração o tipo de serviço, a frequência de início de funcionamento e o número de horas de funcionamento por dia. Segundo o tipo de máquina na qual o reductor é aplicado, na tabela da classificação das aplicações pode-se identificar o tipo de serviço (uniforme, moderado ou pesado). Sucessivamente, na respetiva tabela obtém-se o valor do fator de serviço.

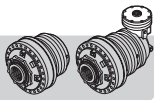

Compressori, ventilatori

| | |
|---------------------------------------|---|
| Compressori assiali e radiali | U |
| Ventilatori a torre di raffreddamento | M |
| Ventilatori a tiraggio indotto | M |
| Compressori a pistoni rotanti | M |
| Compressori turbo | U |

Industria chimica

| | |
|------------------------------------|---|
| Agitatori (materiali liquidi) | U |
| Agitatori (materiali semi-liquidi) | M |
| Centrifughe (pesanti) | M |
| Centrifughe (leggere) | U |
| Tamburi di raffreddamento | M |
| Tamburi di essiccazione | M |
| Miscelatori | M |

Compressori

| | |
|-----------------------|---|
| Compressori a pistone | H |
| Compressori turbo | M |

Convogliatori

| | |
|---|---|
| Nastro trasportatore a piastre | M |
| Sollevatori zavorra | M |
| Convogliatori nastro a sacca | M |
| Convogliatori a nastro (materie voluminose) | M |
| Convogliatori (merce a pezzi) | H |
| Convogliatori a tazza per farinacei | U |
| Convogliatori a catena | M |
| Convogliatori circolari | M |
| Montacarichi | H |
| Montacarichi inclinati | H |
| Convogliatore a nastro in acciaio | M |
| Sollevatori per persone | M |
| Trasportatori a coclea | M |
| Trasportatore a nastro concavo | M |
| Trasportatore a verricello | M |

Gru

| | |
|---|---|
| Meccanismo del braccio di trivellazione | M |
| Meccanismo di montacarico | U |
| Meccanismo rotante | M |
| Meccanismo di traslazione | H |

Draghe

| | |
|---|---|
| Convogliatori a tazza | H |
| Ruote a tazza | H |
| Teste portautensili | H |
| Verricelli per manovre | M |
| Pompe | M |
| Meccanismo rotante | M |
| Meccanismo di traslazione (mezzo cingolato) | H |
| Meccanismo di traslazione (rotaie) | M |

Macchinari per industria alimentare

| | |
|--|---|
| Macchine per il riempimento di bottiglie e contenitori | U |
| Frantumatori di canna | M |
| Coltelli per canna | H |
| Macina per canna | H |
| Impastatrice | H |
| Vasche per macerazione (cristallizzanti) | H |
| Cilindro essiccatore | H |
| Macchinari per imballaggio | U |
| Taglierine per barbabietole da zucchero | M |
| Macchine per il lavaggio di barbabietole da zucchero | M |

Compressors, fans

| | |
|-------------------------------------|---|
| <i>Axial and radial compressors</i> | U |
| <i>Cooling tower fans</i> | M |
| <i>Induced draft fans</i> | M |
| <i>Rotating piston compressors</i> | M |
| <i>Turbo compressors</i> | U |

Chemical Industry

| | |
|---|---|
| <i>Stirrers (liquid materials)</i> | U |
| <i>Stirrers (semi-liquid materials)</i> | M |
| <i>Centrifugal machines (heavy)</i> | M |
| <i>Centrifugal machines (light)</i> | U |
| <i>Cooling drums</i> | M |
| <i>Drying drums</i> | M |
| <i>Mixers</i> | M |

Compressors

| | |
|---------------------------|---|
| <i>Piston compressors</i> | H |
| <i>Turbo compressors</i> | M |

Conveyors

| | |
|---------------------------------------|---|
| <i>Slat conveyor</i> | M |
| <i>Ballast hoister</i> | M |
| <i>Pocket conveyor belt</i> | M |
| <i>Conveyor belt (bulky material)</i> | M |
| <i>Conveyor (goods in pieces)</i> | H |
| <i>Bucket conveyor for flours</i> | U |
| <i>Chain conveyor</i> | M |
| <i>Circular conveyor</i> | M |
| <i>Hoists</i> | H |
| <i>Inclined hoist</i> | H |
| <i>Steel conveyor belt</i> | M |
| <i>Lifts for people</i> | M |
| <i>Screw conveyor</i> | M |
| <i>Concave belt conveyor</i> | M |
| <i>Winch conveyor</i> | M |

Cranes

| | |
|--------------------------------------|---|
| <i>Mechanism of the drilling arm</i> | M |
| <i>Hoist mechanism</i> | U |
| <i>Rotating mechanism</i> | M |
| <i>Translation mechanism</i> | H |

Dredges

| | |
|--|---|
| <i>Bucket conveyor</i> | H |
| <i>Bucket wheels</i> | H |
| <i>Tool-holding heads</i> | H |
| <i>Winches for manoeuvres</i> | M |
| <i>Pumps</i> | M |
| <i>Rotating mechanism</i> | M |
| <i>Translation mechanism (tracked vehicle)</i> | H |
| <i>Translation mechanism (rails)</i> | M |

Machinery for the food industry

| | |
|--|---|
| <i>Machines for filling bottles and containers</i> | U |
| <i>Cane crushers</i> | M |
| <i>Knives for cane</i> | H |
| <i>Cane mill</i> | H |
| <i>Kneading machine</i> | H |
| <i>Tanks for macerating (crystallizers)</i> | H |
| <i>Drying cylinder</i> | H |
| <i>Packing machinery</i> | U |
| <i>Cutters for sugar beet</i> | M |
| <i>Machines for washing sugar beet</i> | M |

Kompressoren, Gebläse

| | |
|-------------------------------|---|
| Axial- und Radialkompressoren | U |
| Kühlturmgebläse | M |
| Gebläse mit Induktionszug | M |
| Rotationskolbenkompressoren | M |
| Turbokompressoren | U |

Chemische Industrie

| | |
|--------------------------------|---|
| Rührwerke (flüssige Stoffe) | U |
| Rührwerke (halbfüssige Stoffe) | M |
| Zentrifugen (schwer) | M |
| Zentrifugen (leicht) | U |
| Kühltrommeln | M |
| Trocknungstrommeln | M |
| Mischer | M |

Kompressoren

| | |
|--------------------|---|
| Kolbenkompressoren | H |
| Turbokompressoren | M |

Förderer

| | |
|------------------------------------|---|
| Plattenförderband | M |
| Ballastheber | M |
| Sackförderband | M |
| Förderband voluminöse Materialien) | M |
| Förderer (lose Waren) | H |
| Becherförderwerke | U |
| Kettenförderer | M |
| Kreiselförderer | M |
| Lastenaufzüge | H |
| Geneigte Lastenaufzüge | H |
| Förderbänder aus | M |
| Personenhebevorrichtungen | M |
| Schneckenförderer | M |
| Hohlbandförderer | M |
| Windenförderer | M |

Kräne

| | |
|---------------------------|---|
| Mechanik des Bohrarms | M |
| Mechanik des Lastenhebers | U |
| Rotationsmechanik | M |
| Translationsmechanik | H |

Nassbagger

| | |
|---------------------------------------|---|
| Becherförderwerke | H |
| Becherrad | H |
| Werkzeugkopfe | H |
| Manöverwinden | M |
| Pumpen | M |
| Rotationsmechanik | M |
| Translationsmechanik (Raupenfahrzeug) | H |
| Translationsmechanik (Schiene) | M |

Maschinen für die Lebensmittelindustrie

| | |
|--|---|
| Maschine zum Füllen von Flaschen und Behältern | U |
| Zuckerrohrbrecher | M |
| Messer für Zuckerrohr | H |
| Mühle für Zuckerrohr | H |
| Knetmaschine | H |
| Veinweichbecken (kristallisierend) | H |
| Trocknungszylinder | H |
| Verpackungsmaschine | U |
| Schneidemaschinen für Zuckerrüben | M |
| Waschmaschinen für Zuckerrüben | M |

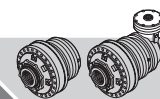
**Compresseurs, ventilateurs**

| | |
|--|---|
| Compresseurs axiaux et radiaux | U |
| Ventilateurs à tour de refroidissement | M |
| Ventilateurs à tirage induit | M |
| Compresseurs à pistons rotatifs | M |
| Compresseurs turbo | U |

Industrie chimique

| | |
|--------------------------------------|---|
| Agitateurs (matériaux liquides) | U |
| Agitateurs (matériaux semi-liquides) | M |
| Centrifuges (lourdes) | M |
| Centrifuges (légères) | U |
| Tambours de refroidissement | M |
| Tambours de séchage | M |
| Mélangeurs | M |

Compresseurs

| | |
|-----------------------|---|
| Compresseurs à piston | H |
| Compresseurs turbo | M |

Convoyeurs

| | |
|--|---|
| Tapis transporteur à plaques | M |
| Élévateurs lest | M |
| Convoyeurs à bande à poches | M |
| Convoyeurs à bande (matières volumineuses) | M |
| Convoyeurs (marchandise par pièces) | H |
| Conv. à godets pour substances farinacées | U |
| Convoyeurs à chaîne | M |
| Convoyeurs circulaires | M |
| Monte-charge | H |
| Monte-charge inclinés | H |
| Conveyeur à bande en acier | M |
| Élévateurs pour personnes | M |
| Transporteurs à vis sans fin | M |
| Transporteur à bande concave | M |
| Transporteur à treuil | M |

Grues

| | |
|-----------------------------|---|
| Mécanisme du bras de forage | M |
| Mécanisme de monte-charge | U |
| Mécanisme rotatif | M |
| Mécanisme de déplacement | H |

Dragues

| | |
|--|---|
| Convoyeurs à godets | H |
| Roues à godets | H |
| Têtes porte-outils | H |
| Treuil pour manœuvre | M |
| Pompes | M |
| Mécanisme rotatif | M |
| Mécanisme de déplacement (véhicules chenillés) | H |
| Mécanisme de déplacement (rails) | M |

Outillages pour industrie alimentaire

| | |
|---|---|
| Machines pour le remplissage de bouteilles et récipients divers | U |
| Broyeurs de canne | M |
| Lames pour canne | H |
| Meule pour canne | H |
| Pétrisseuse | H |
| Bacs pour la macération (cristallisants) | H |
| Cylindre de séchage | H |
| Appareils pour l'emballage | U |
| Cisailles pour betteraves à sucre | M |
| Machines pour le lavage de betteraves à sucre | M |

Compresores, ventiladores

| | |
|--|---|
| Compresores axiales y radiales | U |
| Ventiladores en torre de refrigeración | M |
| Ventiladores de tiro inducido | M |
| Compresores de émbolos giratorios | M |
| Compresores turbo | U |

Industria química

| | |
|--------------------------------------|---|
| Agitadores (materiales líquidos) | U |
| Agitadores (materiales semilíquidos) | M |
| Centrifugas (pesadas) | M |
| Centrifugas (ligeras) | U |
| Tambores de refrigeración | M |
| Tambores de secado | M |
| Mezcladores | M |

Compresores

| | |
|-----------------------|---|
| Compresores de émbolo | H |
| Compresores turbo | M |

Transportadores

| | |
|---|---|
| Cinta transportadora de placas | M |
| Elevadores lastre | M |
| Transportadores de cinta de saco | M |
| Transportadores de cinta (materias voluminosas) | M |
| Transportadores (mercancía en trozos) | H |
| Transportadores de cangilones para harinas | U |
| Transportadores de cadena | M |
| Carruseles | M |
| Montacargas | H |
| Montacargas inclinados | H |
| Transportadores de cinta en acero | M |
| Elevadores para personas | M |
| Transportadores de cóclea | M |
| Transportadores de cinta cóncava | M |
| Transportadores de cabrestante | M |

Grúas

| | |
|------------------------------------|---|
| Mecanismo del brazo de perforación | M |
| Mecanismo de montacargas | U |
| Mecanismo giratorio | M |
| Mecanismo de traslación | H |

Dragas

| | |
|--|---|
| Transportadores de cangilones | H |
| Ruedas de cangilones | H |
| Cabezales portaherramientas | H |
| Cabrestantes para maniobras | M |
| Bombas | M |
| Mecanismo giratorio | M |
| Mecanismo de traslación (medio con orugas) | H |
| Mecanismo de traslación (raíles) | M |

Maquinarias para industria alimentaria

| | |
|--|---|
| Máquinas para llenar botellas y contenedores | U |
| Machacadoras de caña | M |
| Cuchillos para caña | H |
| Muela para caña | H |
| Amasadora | H |
| Cubas para rendido (cristalizantes) | H |
| Cilindro secador | H |
| Máquinas para embalaje | U |
| Cortadoras para remolachas | M |
| Máquinas para lavar remolachas | M |

Compresores, ventiladores

| | |
|---------------------------------------|---|
| Compresores axiais e radiais | U |
| Ventiladores a torre de arrefecimento | M |
| Ventiladores de ação induzida | M |
| Compresores de pistões rotativos | M |
| Compresores turbo | U |

Indústria química

| | |
|--------------------------------------|---|
| Agitadores (materiais líquidos) | U |
| Agitadores (materiais semi-líquidos) | M |
| Centrifugadoras (pesadas) | M |
| Centrifugadoras (ligeiras) | U |
| Tambores de arrefecimento | M |
| Tambores de secagem | M |
| Misturadores | M |

Compresores

| | |
|----------------------|---|
| Compresores a pistão | H |
| Compresores turbo | M |

Canalizadores

| | |
|---|---|
| Tapete transportador de chapas | M |
| Levantadores lastro | M |
| Canalizadores tapete de saco | M |
| Canalizadores a tapete (matérias volumosas) | M |
| Canalizadores (mercadorias a granel) | H |
| Canalizadores de taça para farináceos | U |
| Canalizadores de cadeia | M |
| Canalizadores circulares | M |
| Elevadores | H |
| Elevadores inclinados | H |
| Canalizador a tapete de aço | M |
| Levantadores para pessoas | M |
| Transportadores de parafuso | M |
| Transportador de tapete concavo | M |
| Transportador com guincho | M |

Gruas

| | |
|--------------------------------|---|
| Mecanismo do braço de trivelar | M |
| Mecanismo de monta-cargas | U |
| Mecanismo rotativo | M |
| Mecanismo de translação | H |

Dragas

| | |
|---|---|
| Canalizadores de balde | H |
| Rodas de balde | H |
| Cabeças para utensílios | H |
| Guinchos para manobras | M |
| Bombas | M |
| Mecanismo rotativos | M |
| Mecanismo de translação (meio com lagartas) | H |
| Mecanismo de translação (carris) | M |

Máquinas para a indústria alimentar

| | |
|--|---|
| Máquinas para enchimento de garrafas e recipientes | U |
| Moinhos de cana | M |
| Facas para cana | H |
| Moinhos para cana | H |
| Máquinas de empastar | H |
| Tanques para maceração (cristalizadores) | H |
| Cilindro secador | H |
| Máquinas de embalar | U |
| Cortadoras beterraba de açúcar | M |
| Máquinas para lavagem de de beterrabas de açúcar | M |

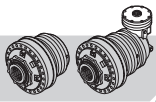

| Macchinari per costruzione | |
|-----------------------------------|---|
| Betoniere | M |
| Montacarichi | M |
| Macchinari per costruzione strade | M |

| Building machinery | |
|---------------------------------|---|
| Concrete mixers | M |
| Hoists | M |
| Machinery for road construction | M |

| Baumaschinen | |
|--------------------|---|
| Betonmischer | M |
| Lastenaufzüge | M |
| Straßenbaumaschine | M |

| Generatori e trasformatori | |
|----------------------------|---|
| Trasformatori di frequenza | H |
| Generatori | H |
| Generatori per saldatrici | H |

| Generators and transformers | |
|--------------------------------|---|
| Frequency transformers | H |
| Generators | H |
| Generators for welding machine | H |

| Generatoren und Transformatoren | |
|----------------------------------|---|
| Frequenztransformatoren | H |
| Generatoren | H |
| Generatoren für Schweißmaschinen | H |

| Lavanderie | |
|-------------|---|
| Invertitori | M |
| Lavatrici | M |
| Stiratrici | M |

| Laundries | |
|------------------|---|
| Inverters | M |
| Washing machines | M |
| Ironing machines | M |

| Wäschereien | |
|----------------|---|
| Umkehrsysteme | M |
| Waschmaschinen | M |
| Bügelmaschinen | M |

| Laminatoi per metalli | |
|--|---|
| Cesoie per laminatoi | H |
| Trasmissioni a catena | M |
| Laminatoi a freddo | H |
| Impianti per fusione continua | H |
| Basamenti refrigeranti | M |
| Cesoie per spuntatura | H |
| Laminatoi per piatti medi e pesanti | H |
| Treni sbozzatori e lingotti | H |
| Manipolatori | H |
| Trancia lamiere | H |
| Raddrizzatore rulli | M |
| Tavole a rulli (pesante) | H |
| Tavole a rulli (leggere) | H |
| Macchine saldatrici a tubo | M |
| Macchine avvolgitrici (guarnizioni fili) | M |
| Banchi da disegno a filo | M |

| Metal rollers | |
|---|---|
| Shears for rolling mills | H |
| Chain drives | M |
| Cold rolling mills | H |
| Plants for continuous milling | H |
| Cooling blocks | M |
| Shears for discarding | H |
| Rolling mills for medium and heavy plates | H |
| Roughing mills and ingots | H |
| Mechanical hands | H |
| Sheet shears | H |
| Roller rectifier | M |
| Roller tables (heavy) | H |
| Roller tables (light) | H |
| Tube-welding machines | M |
| Winding machines (wire washer) | M |
| Flush drawing boards | M |

| Metallwalzstraßen | |
|--|---|
| Scheren für Walzstraßen | H |
| Kettenantrieb | M |
| Kaltwalzstraßen | H |
| Schmelzmaschine für Dauerbetrieb | H |
| Kühlunterbauten | M |
| Schopfscheren | H |
| Walzstraßen für mittelschwere und schwere Bleche | H |
| Vorschmiedezüge und Barren | H |
| Manipolatori | H |
| Blechscherer | H |
| Rollengleichrichter | M |
| Rollentische (schwer) | H |
| Rollentische (leicht) | H |
| Rohrschweißmaschinen | M |
| Wickelmaschinen (Kabelhüllen) | M |
| Zeichentische | M |

| Macchine per la lavorazione del metallo | |
|---|---|
| Contraalberi, alberi in linea | U |
| Pressa per stampaggio a caldo | H |
| Martelli | H |
| Guide ausiliarie, macchine utensili | U |
| Guide principali, macchine utensili | M |
| Macchine per la piallatura di metalli | H |
| Raddrizzatrice per la lamiera | H |
| Pressa | H |
| Pressa per stampi | H |
| Cesoie | M |
| Macchine per piegatrici di metalli | M |

| Machines for working metal | |
|---------------------------------|---|
| Counter shafts, shafts in line | U |
| Press for hot-pressing | H |
| Hammers | H |
| Auxiliary guides, machine tools | U |
| Main guides, machine tools | M |
| Machine for metal planing | H |
| Rectifier for metal sheet | H |
| Presses | H |
| Presses for forging | H |
| Shears | M |
| Machine for folding metals | M |

| Maschinen für die Metallbearbeitung Industrie | |
|---|---|
| Gegenwellen, Welle in Linie | U |
| Pressa per stampaggio a caldo | H |
| Hämmer | H |
| Zusatzführungen, Werkzeugmaschinen | U |
| Hauptführungen, Werkzeugmaschinen | M |
| Hobelmaschinen für Metall | H |
| Gleichrichter für Bleche | H |
| Pressen | H |
| Stanzpressen | H |
| Scheren | M |
| Metallbiegemaschinen | M |

| Industria petrolifera | |
|-----------------------------------|---|
| Pompe conduttrici | M |
| Attrezzatura trapanatrice rotante | H |

| Petrol industry | |
|--------------------------|---|
| Conveying pumps | M |
| Rotating drill equipment | H |

| Petrochimica Industrie | |
|---------------------------------------|---|
| Leitungspumpen | M |
| Ausrüstung für Rotationsbohrmaschinen | H |

| Macchine per la carta | |
|-----------------------|---|
| Calandre | H |
| Manicotto | H |
| Tamburo essiccatore | H |
| Raffinatrice | H |
| Sfibratore per pasta | H |
| Rulli aspiranti | H |
| Pressa aspiranti | H |
| Pressa a umido | H |
| Battitoi | H |

| Machines for paper | |
|--------------------|---|
| Rolling presses | H |
| Coupling | H |
| Drying drum | H |
| Beater | H |
| Grinder for pulp | H |
| Suction rollers | H |
| Suction presses | H |
| Wet presses | H |
| Willows | H |

| Maschinen für die Papierherstellung | |
|-------------------------------------|---|
| Kalander | H |
| Muffe | H |
| Trocknungstrommel | H |
| Feinzeugholländer | H |
| Zerfaserer | H |
| Saugwalzen | H |
| Saugpresse | H |
| Feuchtpresse | H |
| Wolf | H |

| Macchine per la plastica | |
|--------------------------|---|
| Calandre | M |
| Frantoi | M |
| Estrusori | M |
| Miscelatori | M |

| Machines for plastic | |
|----------------------|---|
| Rolling presses | M |
| Grinders | M |
| Extruders | M |
| Mixers | M |

| Maschinen für die Kunststoffherstellung | |
|---|---|
| Kalander | M |
| Brecher | M |
| Extruder | M |
| Mischer | M |

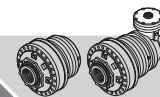
**Outillages pour construction**

| | |
|--|---|
| Bétonnières | M |
| Monte-charge | M |
| Outillages pour la construction des routes | M |

Générateurs et transformateurs

| | |
|------------------------------|---|
| Transformateurs de fréquence | H |
| Générateurs | H |
| Générateurs pour soudeuses | H |

Teintureries

| | |
|------------------|---|
| Inverseurs | M |
| Machines à laver | M |
| Repasseuses | M |

Lamineurs pour métaux

| | |
|---|---|
| Cisailles pour laminaires | H |
| Transmissions à chaîne | M |
| Laminaires à froid | H |
| Installations pour la fusion continue | H |
| Carters réfrigérants | M |
| Cisailles pour chute | H |
| Laminaires pour plateaux moyens et lourds | H |
| Trains ébaucheurs et lingots | H |
| Manipulateurs | H |
| Découpeuse de tôles | H |
| Redresseur de rouleaux | M |
| Planches à rouleaux (lourdes) | H |
| Planches à rouleaux (légères) | H |
| Soudeuses à tube | M |
| Enrouleuses (joints fils) | M |
| Planches à dessin à fil | M |

Outillages pour l'usinage du métal

| | |
|---|---|
| Contre-arbres, arbres en ligne | U |
| Presse pour moulage à chaud | H |
| Marteaux | H |
| Glissières auxiliaires, machines-outils | U |
| Glissières principales, machines-outils | M |
| Machines pour le rabotage de métaux | H |
| Redresseur pour la tôle | H |
| Presses | H |
| Presses pour moules | H |
| Cisailles | M |
| Machines pour cintreuses de métaux | M |

Industrie pétrolière

| | |
|------------------------------|---|
| Pompes à conduction | M |
| Appareils de forage rotatifs | H |

Machines pour le papier

| | |
|-------------------------|---|
| Calandres | H |
| Manchon | H |
| Tambour de séchage | H |
| Raffineuse | H |
| Défibreur pour pâte | H |
| Rouleaux aspirants | H |
| Presses aspirantes | H |
| Presses par voie humide | H |
| Batteurs | H |

Machines pour le plastique

| | |
|-------------|---|
| Calandres | M |
| Broyeurs | M |
| Extrudeuses | M |
| Mélangeurs | M |

Máquinas para construcciones

| | |
|------------------------------------|---|
| Hormigoneras | M |
| Montacargas | M |
| Máquinas para construir carreteras | M |

Generadores y transformadores

| | |
|------------------------------------|---|
| Transformadores de frecuencia | H |
| Generadores | H |
| Generadores para equipos de soldar | H |

Lavanderías

| | |
|--------------|---|
| Inversores | M |
| Lavadoras | M |
| Planchadoras | M |

Laminadores para metales

| | |
|---|---|
| Cizallas para laminadores | H |
| Transmisiones por cadena | M |
| Laminadores en frío | H |
| Plantas para fundición continua | H |
| Bancadas refrigeradoras | M |
| Cizallas para despunte | H |
| Laminadores para piezas planas medias y pesadas | H |
| Trenes desbastadores y lingotes | H |
| Manipuladores | H |
| Cizalla para planchas | H |
| Rectificador de rodillos | M |
| Tablas de rodillos (pesadas) | H |
| Tablas de rodillos (ligeras) | H |
| Máquinas para soldar de tubos | M |
| Máquinas bobinadoras (juntas hilos) | M |
| Bancos de dibujo de hilo | M |

Máquinas para trabajar metales

| | |
|--|---|
| Contraejes, ejes en línea | U |
| Prensa para embutir en caliente | H |
| Martillos | H |
| Guías auxiliares, máquinas herramientas | U |
| Guías principales, máquinas herramientas | M |
| Máquinas para acepillar metales | H |
| Enderezadora para plancha | H |
| Presnas | H |
| Presnas para moldes | H |
| Cizallas | M |
| Máquinas para plegadoras de metales | M |

Industria petrolera

| | |
|-----------------------------|---|
| Bombas conductoras | M |
| Equipo perforador giratorio | H |

Máquinas para papel

| | |
|-------------------------|---|
| Calandrias | H |
| Manguito | H |
| Tambor secador | H |
| Refinadora | H |
| Desfibradora para pasta | H |
| Rodillos aspiradores | H |
| Presnas aspiradoras | H |
| Presnas en húmedo | H |
| Batanes | H |

Máquinas para plástico

| | |
|--------------|---|
| Calandrias | M |
| Lagares | M |
| Extrudidoras | M |
| Mezcladoras | M |

Máquinas para construção

| | |
|-------------------------------------|---|
| Betoneiras | M |
| Elevadores | M |
| Máquinas para a construção estradas | M |

Geradores e transformadores

| | |
|-------------------------------|---|
| Transformadores de frequência | H |
| Geradores | H |
| Geradores para soldadoras | H |

Lavandarias

| | |
|----------------------------|---|
| Inversores | M |
| Máquinas de lavar | M |
| Máquinas de passar a ferro | M |

Laminadores para metais

| | |
|--|---|
| Tesouras para laminadores | H |
| Transmissões de cadeia | M |
| Laminadores a frio | H |
| Instalações para fusão continua | H |
| Bases refrigeradoras | M |
| Tesouras para despontar | H |
| Laminadores para pratos médios e pesados | H |
| Trens desboçar e lingotes | H |
| Manipuladores | H |
| Cortadoras de chapa | H |
| Endireitadores rolos | M |
| Mesas de rolos (pesadas) | H |
| Mesas de rolos (ligeiras) | H |
| Máquinas de soldar de tubo | M |
| Máquinas enroladoras (juntas fios) | M |
| Bancos de desenho a fio | M |

Máquinas para a laboração de metais

| | |
|---------------------------------------|---|
| Contra-veios e veios em linha | U |
| Prensa para moldagem a quente | H |
| Martelos | H |
| Guias auxiliares, máquinas utensílios | U |
| Guias principais, máquinas utensílios | M |
| Máquinas para plainar metais | H |
| Endireitadoras para chapas | H |
| Presnas | H |
| Presnas para moldes | H |
| Tesouras | M |
| Máquinas de quinar metais | M |

Indústria petrolífera

| | |
|------------------------------------|---|
| Bombas conductoras | M |
| Equipamento de trivelação rotativo | H |

Máquinas per a carta

| | |
|------------------------|---|
| Calandras | H |
| Manguito | H |
| Tambor secador | H |
| Refinadora | H |
| Desfibrador para massa | H |
| Rolos aspiradores | H |
| Presnas aspiradoras | H |
| Presnas a húmido | H |
| Batedores | H |

Máquinas para plásticos

| | |
|--------------|---|
| Calandras | M |
| Moinhos | M |
| Extrusores | M |
| Misturadores | M |

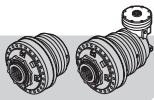

| Pompe | |
|------------------------------------|---|
| Pompa centrifuga (liquidi leggeri) | U |
| Pompa centrifuga (liquidi viscosi) | H |
| Pompe a pistoni | H |
| Pompe a pulsante | H |
| Pompe a pressione | H |

| Pumps | |
|------------------------------------|---|
| Centrifugal pump (light liquids) | U |
| Centrifugal pump (viscose liquids) | H |
| Piston pumps | H |
| Pushbutton pump | H |
| Pressure pump | H |

| Pumpen | |
|--|---|
| Zentrifugalpumpe (leichte Flüssigkeiten) | U |
| Zentrifugalpumpe (viskose Flüssigkeiten) | H |
| Kolbenpumpen | H |
| Tastenspumpen | H |
| Druckpumpen | H |

| Macchinari | |
|--------------|---|
| Calandre | M |
| Estrusori | H |
| Miscelatori | M |
| Impastatrici | H |
| Laminatoi | H |

| Machinery for rubber | |
|----------------------|---|
| Rolling presses | M |
| Extruders | H |
| Mixers | M |
| Kneading machines | H |
| Rolling mills | H |

| Maschinen für die Gummiherstellung | |
|------------------------------------|---|
| Kalander | M |
| Extruder | H |
| Mischer | M |
| Knetmaschinen | H |
| Walzstraßen | H |

| Macchine per la lavorazione della pietra e dell'argilla | |
|---|---|
| Mulino a martelli | H |
| Laminatoi per raffinare | H |
| Interruttore | H |
| Presse per mattoni | H |
| Forno rotante | H |
| Laminatoi a tubo | H |

| Machines for working stone and clay | |
|-------------------------------------|---|
| Hammer mills | H |
| Rolling mills for refining | H |
| Switch | H |
| Presses for bricks | H |
| Rotating kiln | H |
| Tube rolling mills | H |

| Maschinen für die Verarbeitung von Stein und Ton | |
|--|---|
| Hammermühle | H |
| Feinzeugholländer | H |
| Schalter | H |
| Ziegelpressen | H |
| Rotationsöfen | H |
| Strangextruder | H |

| Macchine tessili | |
|-------------------------------------|---|
| Dosatori | M |
| Telai per tessitura | M |
| Macchine per la stampa e la tintura | M |
| Vasca per la concia | M |
| Battitoi | M |

| Textile machines | |
|----------------------------------|---|
| Batchers | M |
| Looms for weaving | M |
| Machines for printing and dyeing | M |
| Tank for tanning | M |
| Willows | M |

| Maschinen für die Textilindustrie | |
|-----------------------------------|---|
| Dosiervorrichtungen | M |
| Webrahmen | M |
| Druck- und Färbemaschinen | M |
| Gerbebecken | M |
| Wolf | M |

| Trattamenti ad acqua | |
|----------------------|---|
| Aeratori | M |
| Pompa a vite | M |

| Water treatments | |
|------------------|---|
| Aerators | M |
| Screw pump | M |

| Wasserbehandlung | |
|------------------|---|
| Lüfter | M |
| Schraubenpumpen | M |

| Macchine per la lavorazione del legno | |
|---------------------------------------|---|
| Scortecciatrici | H |
| Macchine per la piallatura | M |
| Telaio per seghe | H |
| Macchine per la lavorazione del legno | U |

| Machines for working wood | |
|---------------------------|---|
| Bark-peeling machines | H |
| Planing machines | M |
| Frame for saws | H |
| Machines for working wood | U |

| Maschinen für die Holzverarbeitende Industrie | |
|---|---|
| Schälmaschinen | H |
| Hobelmaschinen | M |
| Rahmen für Sägen | H |
| Maschine für die Holzverarbeitung | U |

| f _s | | U Uniforme Gleichmäßig | | | M Moderato Gemäßigt | | | H Pesante Heavy Schwer | | |
|--|--------|--|-------|--------|---------------------|-------|--------|------------------------|-------|--------|
| | | Ore di funzionamento giornaliere / Hours of operation per day / Betriebsstunde pro Tag | | | | | | | | |
| | | <1 | 1 ÷ 8 | 8 ÷ 24 | <1 | 1 ÷ 8 | 8 ÷ 24 | <1 | 1 ÷ 8 | 8 ÷ 24 |
| N° avviamenti/ora No. of start-ups/hour Anzahl Startvorgänge/ Stunde | < 6 | 0.7 | 0.9 | 1.1 | 0.9 | 1.1 | 1.3 | 1 | 1.3 | 1.7 |
| | 6 ÷ 60 | 0.9 | 1.2 | 1.4 | 1.1 | 1.4 | 1.6 | 1.4 | 1.7 | 2 |
| | > 60 | 1.2 | 1.5 | 1.7 | 1.4 | 1.7 | 2 | 1.7 | 2.1 | 2.5 |

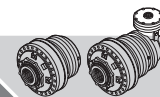

| Pompes | |
|--------------------------------------|---|
| Pompe centrifuge (liquides légers) | U |
| Pompe centrifuge (liquides visqueux) | H |
| Pompes à pistons | H |
| Pompes à touche | H |
| Pompes à pression | H |

| Outillages pour le caoutchouc | |
|-------------------------------|---|
| Calandres | M |
| Extrudeuses | H |
| Mélangeurs | M |
| Pétrisseuses | H |
| Laminoirs | H |

| Machines pour l'usinage de la pierre et de l'argile | |
|---|---|
| Moulins à marteaux | H |
| Laminoirs pour ennobrir | H |
| Interrupteur | H |
| Presses pour briques | H |
| Four rotatif | H |
| Laminoirs à tube | H |

| Machines textiles | |
|---|---|
| Doseurs | M |
| Métiers à tisser | M |
| Machines pour l'impression et la finition | M |
| Bac pour le traitement des fibres | M |
| Batteurs | M |

| Traitements à eau | |
|-------------------|---|
| Aérateurs | M |
| Pompe à vis | M |

| Machines pour le travail du bois | |
|----------------------------------|---|
| Ecorceuses | H |
| Machines pour le rabotage | M |
| Châssis pour scies | H |
| Machines pour le travail du bois | U |

| Bombas | |
|--------------------------------------|---|
| Bomba centrifuga (líquidos ligeros) | U |
| Bomba centrifuga (líquidos viscosos) | H |
| Bombas de émbolos | H |
| Bombas de pulsión | H |
| Bombas de presión | H |

| Máquinas para caucho | |
|----------------------|---|
| Calandrias | M |
| Extrudidoras | H |
| Mezcladoras | M |
| Amasadoras | H |
| Laminadoras | H |

| Máquinas para labrar piedras y tratar arcillas | |
|--|---|
| Molino de martillos | H |
| Laminador para refinar | H |
| Interruptor | H |
| Presas para ladrillos | H |
| Horno giratorio | H |
| Laminadores de tubo | H |

| Máquinas textiles | |
|--------------------------------|---|
| Dosificadores | M |
| Telares | M |
| Máquinas para estampar y teñir | M |
| Cubas para curtir | M |
| Batanes | M |

| Tratamiento con agua | |
|----------------------|---|
| Ventiladores | M |
| Bomba de caracol | M |

| Máquinas para labrar la madera | |
|--------------------------------|---|
| Descortezadoras | H |
| Máquinas de acepillar | M |
| Bastidor para sierras | H |
| Máquinas para labrar la madera | U |

| Bombas | |
|--------------------------------------|---|
| Bomba centrifuga (líquidos ligeiros) | U |
| Bomba centrifuga (líquidos viscosos) | H |
| Bombas a pistões | H |
| Bombas a botão | H |
| Bombas a pressão | H |

| Máquinas para borracha | |
|------------------------|---|
| Calandras | M |
| Extrusores | H |
| Misturadores | M |
| Máquinas de empastar | H |
| Laminadores | H |

| Máquinas para laboração de pedras e argila | |
|--|---|
| Moinho de martelos | H |
| Laminadores para refinar | H |
| Interruptor | H |
| Pressas para tijolos | H |
| Forno rotativo | H |
| Laminadores a tubo | H |

| Máquinas têxteis | |
|-------------------------------|---|
| Dosadores | M |
| Chassis para tecelagem | M |
| Máquinas de estampar e tingir | M |
| Tanques para curtumes | M |
| Batedores | M |

| Tratamentos de água | |
|---------------------|---|
| Arejadores | M |
| Bomba de parafuso | M |

| Máquinas para laboração da madeira | |
|--|---|
| Máquina de descascar troncos | H |
| Plainas | M |
| Chassis para serras | H |
| Máquinas para a transformação de madeira | U |

| f _s | | U Uniforme Uniforme | | | M Modéré Moderado | | | H Lourd Pesado | | |
|-------------------------------|--------|--|-------|--------|-------------------|-------|--------|----------------|-------|--------|
| | | Heures de fonctionnement par jour / Horas de funcionamiento al día / Horas de funcionamento ao dia | | | | | | | | |
| | | <1 | 1 ÷ 8 | 8 ÷ 24 | <1 | 1 ÷ 8 | 8 ÷ 24 | <1 | 1 ÷ 8 | 8 ÷ 24 |
| Q.té de mise en service/heure | < 6 | 0.7 | 0.9 | 1.1 | 0.9 | 1.1 | 1.3 | 1 | 1.3 | 1.7 |
| Nº arranques/hora | 6 ÷ 60 | 0.9 | 1.2 | 1.4 | 1.1 | 1.4 | 1.6 | 1.4 | 1.7 | 2 |
| Nº entradas em serviço/hora | > 60 | 1.2 | 1.5 | 1.7 | 1.4 | 1.7 | 2 | 1.7 | 2.1 | 2.5 |

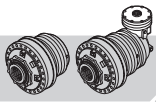

3.16 Potenza termica

P_t [kW]

La potenza termica è quella potenza che, applicata in entrata al riduttore in funzionamento continuo prolungato, stabilizza la temperatura dell'olio all'interno del riduttore a 90°C, nelle seguenti condizioni di prova:

- velocità in entrata 1000 min⁻¹;
- lubrificazione per sbattimento;
- riduttore in posizione orizzontale non soggetto a ricircolo d'aria;
- quantità di olio corrispondente a metà riempimento;
- olio minerale ISO VG 150;
- temperatura ambiente 20°C.

Il valore della potenza termica di ciascun riduttore è riportato nella relativa tabella dei dati tecnici.

Per i riduttori con tipo di uscita UC, incrementare la potenza termica del 20%.

Per condizioni differenti da quelle sopra specificate il valore della potenza termica va corretto, come spiegato più avanti.

In presenza di un freno negativo (in condizioni di funzionamento continuo), la temperatura dell'olio all'interno del riduttore è soggetta ad un continuo innalzamento.



Il montaggio del riduttore in un vano di dimensioni ridotte diminuisce notevolmente la capacità di smaltimento della potenza termica.

Se la potenza applicata in ingresso al riduttore dovesse superare il valore di potenza termica ammissibile o comunque il riduttore si trovasse a operare in un vano di ridotte dimensioni o con scarso ricircolo d'aria, si consiglia di impiegare un sistema ausiliario di raffreddamento a ricircolo d'olio.

3.17 Carico radiale in entrata/uscita

$F_{r,1}$, $F_{r,2}$

In corrispondenza delle entrate veloci tipo leggera, media e pesante e dei supporti uscita che prevedono la presenza di un carico radiale, sono riportate le curve del carico radiale ammissibile $F_{r,1}$ o $F_{r,2}$ in funzione della ascissa x (distanza da un riferimento opportuno).

Il valore di carico radiale ammissibile è riferito ad una durata dei cuscinetti, calcolata in base alla norma ISO 281, pari rispettivamente a:

- $10^7 n_1 \cdot h$ per gli alberi entrata;
- $10^5 n_2 \cdot h$ per gli alberi uscita

3.16 Thermal power

P_t [kW]

Thermal power is the power that, applied at input to the continuously working reduction gear, stabilises the temperature of the oil inside the reduction gear at 90°C under the following test conditions:

- *input speed: 1000 min⁻¹;*
- *oil splash lubrication;*
- *reduction gear in a horizontal position not subject to air recirculation;*
- *quantity of oil corresponding to the half full mark;*
- *ISO VG 150 mineral oil;*
- *ambient temperature 20°C.*

The value of the thermal power of each reduction gear is given in the relative technical data table.

For reduction gears with a UC output, increase thermal power by 20%.

For conditions differing from those described above, the thermal power value has to be corrected as explained further on.

When we have a negative brake (in continuous duty conditions), the temperature of oil inside the reduction gear keeps rising.

Mounting the reduction gear inside a small compartment reduces thermal power dispersion capacity considerably.

If the power applied in input to the reduction gear exceeds the permitted thermal power or if the reduction gear is working inside a small compartment or with only a small change of air, we suggest an oil recirculation type cooling circuit.

3.17 Input/output radial load

$F_{r,1}$, $F_{r,2}$

The curves of the permitted radial load $F_{r,1}$ or $F_{r,2}$ as a function of abscissa x (distance from a suitable reference) are given by the fast inputs (light, medium and heavy types) and by the output supports that allow a radial load.

The permitted radial load value refers to a duration of the bearings calculated on the basis of the ISO 281 standard and equivalent to, respectively:

- *$10^7 n_1 \cdot h$ for the input shafts;*
- *$10^5 n_2 \cdot h$ for the output shafts*

3.16 Wärmeleistung

P_t [kW]

Die Wärmeleistung ist der Wert, der – angewendet am Eingang der Untersetzung bei längerem Dauerbetrieb – die Temperatur des Öls im Inneren vom Planetengetriebe unter den folgenden Testbedingungen auf 90°C stabilisiert:

- Eingangsgeschwindigkeit 1000 min⁻¹;
- Schlagschmierung;
- Untersetzung in horizontaler Lage und nicht der Luftzirkulation ausgesetzt;
- Ölmenge, die der halben Füllung entspricht;
- Mineralöl ISO VG 150;
- Umgebungstemperatur 20°C.

Der Wert der Wärmeleistung der einzelnen Planetengetriebe ist in der Tabelle mit den technischen Daten aufgeführt.

Bei Untersetzungen mit Ausgängen vom Typ UC muss die Wärmeleistung um 20 % erhöht werden.

Bei Bedingungen, die von den oben genannten abweichen, muss der Wert der Wärmeleistung korrigiert werden, wie im Folgenden noch erläutert wird.

Wenn eine Negativbremse vorhanden ist (bei Dauerbetrieb), steigt die Temperatur vom Öl im Planetengetriebe ständig an.

Die Montage vom Planetengetriebe in einem Fach mit reduzierten Abmessungen reduziert die Fähigkeit zur Ableitung der Wärmeleistung.

Falls die am Eingang vom Planetengetriebe anliegende Leistung die zulässige Wärmeleistung übersteigt oder falls das Planetengetriebe in einem Fach mit reduzierten Abmessungen oder schlechter Luftzirkulation montiert wird, muss eine Ölkühlung installiert werden.

3.17 Querlast am Eingang/Ausgang

$F_{r,1}$, $F_{r,2}$

In Bezug auf die schnellen Eingänge vom Typ leicht, mittel und schwer und die Lager am Ausgang, bei denen das Vorhandensein einer Last vorgesehen ist, werden die Kurven der zulässigen Querlast $F_{r,1}$ oder $F_{r,2}$ in Abhängigkeit von der X-Achse dargestellt (Abstand von einem geeigneten Bezugspunkt).

Der Wert der zulässigen Querlast bezieht sich auf eine Lebensdauer der Lager, die nach Vorgabe der Norm ISO 281 berechnet wird, und zwar:

- $10^7 n_1 \cdot h$ für Eingangswellen;
- $10^5 n_2 \cdot h$ für Ausgangswellen

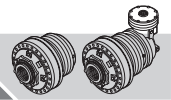

3.16 Puissance thermique

P_t [kW]

La puissance thermique est la puissance qui, appliquée à l'entrée au réducteur en marche continue prolongée, stabilise la température de l'huile à l'intérieur du réducteur à 90°C, dans les conditions d'essai suivantes:

- vitesse à l'entrée 1000 min⁻¹;
- lubrification par barbotage ;
- réducteur en position horizontale non sujette à recirculation d'air;
- quantité d'huile correspondant à un nourrissage à mi-hauteur;
- huile minérale ISO VG 150;
- température ambiante 20°C.

La valeur de la puissance thermique de chaque réducteur est indiquée sur le tableau des caractéristiques techniques.

Pour les réducteurs avec un type de sortie UC, augmenter la puissance thermique de 20 %.

Pour des conditions différentes de celles qui sont indiquées ci-dessus, la valeur de la puissance thermique doit être corrigée (voir explications plus loin).

En présence d'un frein négatif (dans des conditions de service continu), la température de l'huile à l'intérieur du réducteur est sujette à une hausse continue.



Le montage du réducteur dans un espace de petites dimensions réduit considérablement la capacité d'évacuation de la puissance thermique.

Si la puissance appliquée à l'entrée du réducteur devait dépasser la valeur de puissance thermique admissible ou si le réducteur devait fonctionner dans un espace de petites dimensions ou avec une faible recirculation d'air, il est recommandé d'employer un circuit auxiliaire de refroidissement à recirculation d'huile.

3.17 Charge radiale à l'entrée/à la sortie

$F_{r,1}$, $F_{r,2}$

À l'endroit des entrées rapides de type léger, moyen ou lourd et des supports à la sortie qui prévoient la présence d'une charge se trouvent les courbes de la charge radiale admissible $F_{r,1}$ ou $F_{r,2}$ en fonction de l'abscisse x (distance d'un repère adéquat).

La valeur de charge radiale admissible se rapporte à une durabilité des roulements, calculée conformément à la norme ISO 281, correspondant, respectivement à:

- $10^7 n_1 \cdot h$ pour les arbres à l'entrée;
- $10^5 n_2 \cdot h$ pour les arbres à la sortie

3.16 Potencia térmica

P_t [kW]

La potencia térmica es la potencia que, aplicada en la entrada del reductor en funcionamiento continuo prolongado, estabiliza la temperatura del aceite dentro del reductor en 90°C, en las siguientes condiciones de prueba:

- velocidad en entrada : 1000 min⁻¹;
- lubricación por circulación y salpicadura;
- reductor en posición horizontal no sujeto a recirculación de aire;
- cantidad de aceite correspondiente a medio llenado;
- aceite mineral ISO VG 150;
- temperatura ambiente 20°C.

El valor de la potencia térmica de cada reductor se indica en la correspondiente tabla de los datos técnicos.

Para los reductores con salida de tipo UC, incrementar la potencia térmica un 20%.

Para condiciones distintas de las especificadas más arriba, se debe corregir el valor de la potencia térmica, como explicado más adelante.

En presencia de un freno negativo (en condiciones de funcionamiento continuo), la temperatura del aceite dentro del reductor está sujeta a una subida continua.

El montaje del reductor en un espacio de medidas reducidas disminuye notablemente la capacidad de eliminación de la potencia térmica.

Si la potencia aplicada en la entrada del reductor superara el valor de potencia térmica admitido o de todas maneras el reductor trabajara en un espacio de medidas reducidas o con escasa recirculación de aire, se aconseja utilizar un sistema auxiliar de refrigeración por circulación de aceite.

3.17 Carga radial en entrada/salida

$F_{r,1}$, $F_{r,2}$

En correspondencia con las entradas rápidas de tipo ligero, medio y pesado y de los soportes de salida que prevén la presencia de una carga, se presentan las curvas de la carga radial admitida $F_{r,1}$ ó $F_{r,2}$ en función de la abscisa x (distancia con respecto a una oportuna referencia).

El valor de carga radial admitida se refiere a una duración de los cojinetes, calculada según la norma ISO 281, equivalente respectivamente a:

- $10^7 n_1 \cdot h$ para los ejes de entrada;
- $10^5 n_2 \cdot h$ para los ejes de salida

3.16 Potência térmica

P_t [kW]

A potência térmica é a potência que, aplicada em entrada no redutor em funcionamento continuo prolongado, estabiliza a temperatura do óleo no interior do redutor a 90°C, nas seguintes condições de prova:

- velocidade em entrada 1000 min⁻¹;
- lubrificação por batimento;
- redutor em posição horizontal não sujeito a recirculação do ar;
- quantidade de óleo correspondente a meio enchimento;
- óleo mineral ISO VG 150;
- temperatura ambiente 20°C.

O valor da potência térmica de cada reductor é indicado na relativa tabela dos dados técnicos.

Para os redutores com tipo de saída UC, aumentar a potência térmica de 20%.

Para condições diferentes daquelas acima especificadas o valor da potência térmica deve ser corrigido, como referido mais adiante.

Na presença de um freio negativo (em condições de funcionamento continuo), a temperatura do óleo no interior do reductor é sujeita a aumento continuo.

A montagem do reductor num ambiente de dimensões reduzidas diminui notavelmente a capacidade de eliminação da potência térmica.

Se a potência aplicada em entrada no reductor superará o valor de potência térmica admissível ou em qualquer caso, o reductor se encontrasse a trabalhar num ambiente de dimensões reduzidas ou com recirculação limitada do ar, é aconselhável usar um sistema auxiliar de arrefecimento com recirculação do óleo.

3.17 Carga radial em entrada/saída

$F_{r,1}$, $F_{r,2}$

Em correspondência das entradas rápidas de tipo ligeiro, médio e pesado, que prevêm a presença de uma carga, estão indicadas as curvas da carga radial admissível $F_{r,1}$ ou $F_{r,2}$ em função da abscissa x (distância em relação a uma referência oportuna).

O valor de carga radial admissível é referido a uma duração dos rolamentos, calculada segundo a norma ISO 281, equivalente, respetivamente, a:

- $10^7 n_1 \cdot h$ para os veios de entrada;
- $10^5 n_2 \cdot h$ para os veios de saída

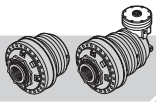

Per valori differenti dei fattori di durata è necessario introdurre un coefficiente correttivo $k_{r,1}$ o $k_{r,2}$ che si ricava da un'ulteriore curva, riportata in prossimità di quella relativa al carico radiale.

For different duration factor values a corrective coefficient $k_{r,1}$ or $k_{r,2}$ has to be used, found in another curve in proximity of the one relative to the radial load.

Für andere Zeitfaktoren muss ein Korrekturfaktor $k_{r,1}$ oder $k_{r,2}$ eingeführt werden, der einer weiteren Kurve entnommen werden kann, die neben der Kurve der Querlast abgetragen ist.



Per i supporti uscita con albero femmina scanalato o maschio cavo, le curve del carico radiale ammissibile non sono volutamente riportate, in quanto tali supporti non sono generalmente idonei a sopportare carichi radiali; tuttavia per applicazioni che prevedono la presenza di carichi radiali, è possibile valutare l'idoneità di tali supporti uscita e la durata dei cuscinetti contattando il Servizio Tecnico Reggiana Riduttori.

For the output supports with a female splined or male hollow shaft, the curves of the permitted radial load are not given on purpose as they are usually unsuitable for supporting radial loads; however, for applications where radial loads are foreseen, the suitability of such output supports and bearing life can be evaluated, contacting the Reggiana Riduttori Technical Service.

Für Lager am Ausgang mit Keilnutensteckwelle oder Hohlsteckwelle wurden auf die Kurven der zulässigen Querlast verzichtet, da diese Lager in der Regel nicht für die Belastung durch Querlasten geeignet sind. Bei Anwendungen, die das Anliegen von Querlasten vorsehen, kann zusammen mit dem Technischen Kundendienst von Reggiana Riduttori die Eignung dieser Lager am Ausgang und die Lebensdauer der Lager geprüft werden.

3.18 Carico assiale in uscita

$F_{a,2}$

Su tutte le tipologie di supporto uscita è ammessa la presenza di un carico assiale in verso entrante o uscente, purché questo sia applicato in maniera non eccentrica rispetto all'albero uscita.

3.18 Output axial load

$F_{a,2}$

An axial load, incoming or outgoing, is allowed on all types of output support provided it is not applied eccentrically in relation to the output shaft.

3.18 Achslast am Ausgang

$F_{a,2}$

Bei Anliegen von Achslast am Lager am Ausgang ist das Anliegen einer Achslast in eingehende oder ausgehende Richtung zulässig, vorausgesetzt, die Last liegt nicht außermittig bezogen auf die Ausgangswelle anliegt.

| | | Grandezza / Size / Größe | | | | | | | | | | | | | | | |
|--------------|-----|--------------------------|-------|-------|-------|-------|-------|-------|-------|-------|-------|-------|-------|-------|--------|--------|--------|
| | | 65 | 105 | 110 | 210 | 210S | 310 | 310S | 510 | 510S | 710 | 710S | 810 | 810S | 1010 | 1700 | 1700B |
| $F_{a,2}$ | [N] | 18000 | 10000 | 10000 | 10000 | 35000 | 35000 | 38000 | 35000 | 38000 | 38000 | 45000 | 58000 | 67000 | 60000 | 73000 | 73000 |
| $F_{a,2max}$ | [N] | 18000 | 18000 | 18000 | 18000 | 40000 | 40000 | 40000 | 40000 | 40000 | 40000 | 90000 | 90000 | 90000 | 100000 | 100000 | 100000 |



In presenza di carico assiale sul supporto uscita, o contemporaneamente di carico radiale e assiale, verificare l'idoneità del riduttore contattando il Servizio Tecnico Reggiana Riduttori.

When there is an axial load or an axial and radial load on the output support, verify the suitability of the reduction gear contacting the Reggiana Riduttori Technical Service.

Wenn es eine axiale Belastung oder eine axiale und radiale Belastung der Ausgang-Unterstützung, Verifizieren der Eignung des Untersetzungsgetriebe Kontaktaufnahme mit dem Reggiana Riduttori Technical Service.

3.19 Condizioni ambientali e limiti di impiego e funzionamento

La temperatura ambiente raccomandata per i riduttori epicicloidali Reggiana Riduttori è compresa nell'intervallo $-20^{\circ}\text{C}/+40^{\circ}\text{C}$.

Condizioni differenti di impiego sono, tuttavia, possibili, utilizzando particolari accorgimenti progettuali da concordare in modo specifico insieme al Servizio Tecnico Reggiana Riduttori.

Non è consentito il funzionamento al di sopra della temperatura massima ambiente di $+40^{\circ}\text{C}$ a meno di non operare a potenze inferiori alla potenza termica ammessa e dopo un opportuno test di funzionamento.

3.19 Environmental conditions and use/operating limits

The ambient temperature recommended for Reggiana Riduttori reduction gears ranges between -20°C and $+40^{\circ}\text{C}$.

Different conditions of use are however possible, taking certain designing measures which have to be agreed specifically with the Reggiana Riduttori technical service.

Operation is forbidden above the maximum ambient temperature of 40°C unless you are working at powers below the permitted thermal power and after conducting suitable operating tests.

3.19 Bedingungen am Standort und Einschränkungen für den Gebrauch

Die empfohlene Umgebungstemperatur bei Gebrauch der Planetengetriebe von Reggiana Riduttori liegt zwischen -20°C und $+40^{\circ}\text{C}$.

Bei abweichenden Bedingungen müssen die Planetengetriebe entsprechend verändert werden nach ausdrücklicher Absprache mit dem Technischen Kundendienst von Reggiana Riduttori.

Ein Betrieb bei einer Umgebungstemperatur von über $+40^{\circ}\text{C}$ ist nicht zulässig, es sei denn mit Leistungen unterhalb der zulässigen Wärmeleistung und nach einem Funktionstest.

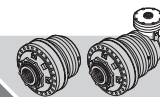

FR ES PT

Pour des valeurs différentes des facteurs de durée, il faut entrer un coefficient correctif $k_{r,1}$ ou $k_{r,2}$ qu'on obtient à partir d'une autre courbe, se trouvant à proximité de la courbe relative à la charge radiale.

Para valores distintos de los factores de duración es necesario introducir un coeficiente de corrección $k_{r,1}$ o $k_{r,2}$ que se saca de una ulterior curva, presentada al lado de aquella referente a la carga radial.

No caso de valores diferentes dos fatores de duração é necessário introduzir um coeficiente corretivo $k_{r,1}$ ou $k_{r,2}$ que se obtém de uma sucessiva curva, indicada próxima daquela relativa à carga radial.



Pour les supports de sortie avec un arbre femelle cannelé ou mâle creux, les courbes de la charge radiale admissible ne sont pas, intentionnellement, indiquées, car ces supports ne sont généralement pas faits pour soutenir des charges radiales; pour des applications prévoyant la présence de charges radiales, il est toutefois possible d'estimer le bon choix de ces supports de sortie et la durabilité des roulements en contactant le service technique Reggiana Riduttori.

Para los soportes de salida con eje hembra acanalado o macho hueco, las curvas de la carga radial admitida han sido expresamente omitidas, ya que dichos soportes en general no son idóneos para soportar cargas radiales; de todas maneras, para aplicaciones que prevén la presencia de cargas radiales, es posible evaluar la idoneidad de dichos soportes de salida y la duración de los cojinetes contactando con el Servicio Técnico de Reggiana Riduttori.

No caso de suportes de saída com veio fêmea com ranhuras ou macho oco, as curvas da carga radial admissível não foram indicadas, dado que geralmente tais suportes não são idóneos a suportar cargas radiais; contudo para aplicações que prevêm a presença de cargas radiais, é possível avaliar a idoneidade de tais suportes de saída e a duração dos rolamentos contactando o Serviço Técnico Reggiana Riduttori.

3.18 Charge axiale à la sortie

$F_{a,2}$

Sur toutes les typologies de support de sortie, la présence d'une charge axiale vers l'entrée ou vers la sortie est admise, à condition qu'elle soit appliquée de manière non excentrique par rapport à l'arbre de sortie.

3.18 Carga axial en salida

$F_{a,2}$

En todos los tipos de soporte de salida se admite la presencia de una carga axial en dirección entrante o saliente, siempre que dicha carga sea aplicada de manera no excéntrica con respecto al eje de salida.

3.18 Carga axial em saída

$F_{a,2}$

Em todos os tipos de suporte de saída é admitida a presença de uma carga axial no sentido de entrada ou saída, desde que o mesmo seja aplicado de modo não excêntrico respeito ao veio de saída.

| | Grandeur / Talla / Grandeza | | | | | | | | | | | | | | | |
|------------------|-----------------------------|-------|-------|-------|-------|-------|-------|-------|-------|-------|-------|-------|-------|--------|--------|--------|
| | 65 | 105 | 110 | 210 | 210S | 310 | 310S | 510 | 510S | 710 | 710S | 810 | 810S | 1010 | 1700 | 1700B |
| $F_{a,2}$ [N] | 18000 | 10000 | 10000 | 10000 | 35000 | 35000 | 38000 | 35000 | 38000 | 38000 | 45000 | 58000 | 67000 | 60000 | 73000 | 73000 |
| $F_{a,2max}$ [N] | 18000 | 18000 | 18000 | 18000 | 40000 | 40000 | 40000 | 40000 | 40000 | 40000 | 90000 | 90000 | 90000 | 100000 | 100000 | 100000 |



En présence de charge axiale ou charge radiale et axiale sur le support de sortie, vérifier le bon choix du réducteur en contactant le service technique Reggiana Riduttori

En presencia de carga axial o carga radial y axial sobre el soporte de salida, cabe comprobar la idoneidad del reductor contactando con el Servicio Técnico de Reggiana Riduttori.

Na presença de carga axial ou carga radial e axial no suporte saída, verificar a idoneidade do reductor contactando o Serviço Técnico Reggiana Riduttori

3.19 Conditions ambiantes et limites d'utilisation et de fonctionnement

La température ambiante recommandée pour les réducteurs épicycloïdaux Reggiana Riduttori est comprise entre $-20^{\circ}\text{C}/+40^{\circ}\text{C}$.

Des conditions d'utilisation différentes sont toutefois possibles, en ayant recours à des mesures conceptuelles particulières à décider en accord avec le service technique Reggiana Riduttori.

Le fonctionnement au-delà de la température ambiante maximum de 40°C n'est pas autorisé, à moins que le fonctionnement ne soit pas à des puissances inférieures à la puissance thermique admise et après un test de fonctionnement spécial.

3.19 Condiciones ambientales y límites de utilización y funcionamiento

La temperatura ambiente recomendada para los reductores epicicloidales Reggiana Riduttori es entre -20°C y $+40^{\circ}\text{C}$.

Condiciones de utilización distintas son, de todas maneras, posibles, utilizando especiales soluciones de proyecto a concertar de manera específica con el Servicio técnico Reggiana Riduttori.

No se permite el funcionamiento por encima de la temperatura ambiente máxima de 40°C salvo que se trabaje con potencias menores que la potencia térmica admitida y después de efectuar un oportuno test de funcionamiento.

3.19 Condições ambientais e limites de emprego e funcionamento

A temperatura ambiente recomendada para os redutores epicicloidais Reggiana Riduttori é compreendida no intervalo $-20^{\circ}\text{C}/+40^{\circ}\text{C}$.

Condições diferentes de emprego são, contudo, possíveis, recorrendo a algumas soluções durante a fase de projeto e a concordar de modo específico juntamente com Serviço Técnico Reggiana Riduttori.

Não é consentido o funcionamento acima da temperatura máxima ambiente de $+40^{\circ}\text{C}$ a não ser que se trabalhe com potências inferiores à potência térmica admitida e depois de um oportuno teste de funcionamento.

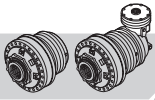
**4 SELEZIONE DEI RIDUTTORI**

Per la selezione del riduttore idoneo per una data applicazione è necessario conoscere:

- la velocità in entrata n_1 [min^{-1}];
- la velocità in uscita richiesta n_{2r} [min^{-1}];
- la coppia in uscita richiesta T_{2r} [Nm];
- la durata richiesta h_r [h];
- il fattore di servizio f_s , calcolato in base al tipo di applicazione e alle condizioni di utilizzo.

A partire da questi dati si determinano, quindi, il rapporto di riduzione richiesto:

4 SELECTING THE REDUCTION GEARS

To choose the reduction gear most suited for a given application it is necessary to know:

- input speed n_1 [min^{-1}];
- required output speed n_{2r} [min^{-1}];
- required output torque T_{2r} [Nm];
- the duration required h_r [h];
- the service factor f_s , calculated on the basis of the type of application and conditions of use.

With these data we can determine the reduction ratio required:

4 AUSWAHL VOM PLANETENGETRIEBE

Um das Planetengetriebe auszuwählen, das für die geplante Anwendung am besten geeignet ist, müssen folgende Werte bekannt sein:

- die Geschwindigkeit am Eingang n_1 [min^{-1}];
- die verlangte Geschwindigkeit am Ausgang n_{2r} [min^{-1}];
- das verlangte Drehmoment am Ausgang T_{2r} [Nm];
- die verlangte Dauer h_r [h];
- der Betriebsfaktor f_s , berechnet anhand der Art der Anwendung und den Bedingungen am Standort.

Aus diesen Werten wird das erforderliche Untersetzungsverhältnis:

$$i_r = \frac{n_1}{n_{2r}}$$

la coppia in uscita corretta:

the corrected output torque:

das korrigierte Drehmoment am Ausgang:

$$T_{2c} = T_{2r} \cdot f_s$$

e il fattore di durata:

and the duration factor:

und der Zeitfaktor berechnet:

$$f_{h,2} = n_{2r} \cdot h_r$$

Dalla tabella delle coppie nominali scegliere una grandezza di riduttore che abbia coppia nominale maggiore della T_{2c} . Quindi dalla tabella dei dati tecnici, posta all'inizio della sezione relativa alla grandezza individuata, selezionare un riduttore che abbia rapporto di riduzione i prossimo a quello richiesto i_r , assicurandosi che la coppia applicabile in uscita T_2 sia maggiore della T_{2c} in corrispondenza della colonna relativa ad un valore di $n_2 \times h$ maggiore o uguale al fattore di durata $f_{h,2}$ calcolato.

Choose a reduction gear size from the nominal torque table that has a nominal torque greater than T_{2c} . Then, from the technical data table (at the beginning of the section of the size wanted) select a reduction gear with a reduction ratio i near to what is wanted i_r , making sure that the transmissible output torque T_2 is greater than T_{2c} by the column relative to a value of $n_2 \times h$ greater or the same as the duration factor $f_{h,2}$ calculated.

Aus der Tabelle mit den Nenndrehmomenten eine Größe vom Planetengetriebe auswählen, deren Nenndrehmoment größer ist als T_{2c} .

Dann aus der Tabelle mit den technischen Daten, die sich am Anfang vom Abschnitt der ermittelten Größe befindet, das Planetengetriebe auswählen, dessen Untersetzungsverhältnis i etwa dem verlangten Untersetzungsverhältnis i_r entspricht und dabei sicherstellen, dass das am Ausgang anlegbare Drehmoment T_2 größer ist als der Wert T_{2c} , und zwar in der Spalte vom Wert $n_2 \times h$, der größer als oder gleichgroß wie der berechnete Zeitfaktor $f_{h,2}$ ist.

Esempio

Si vuole scegliere un riduttore lineare che funzioni alle seguenti condizioni:

- velocità in entrata $n_1 = 1500 \text{ min}^{-1}$
- velocità in uscita richiesta $n_{2r} = 15 \text{ min}^{-1}$
- coppia in uscita richiesta $T_{2r} = 3500 \text{ Nm}$
- durata richiesta $h_r = 5000 \text{ h}$
- fattore di servizio $f_s = 1.3$

Example

You want to choose a linear reduction gear that works at the following conditions:

- input speed $n_1 = 1500 \text{ min}^{-1}$
- required output speed $n_{2r} = 15 \text{ min}^{-1}$
- required output torque $T_{2r} = 3500 \text{ Nm}$
- the duration required $h_r = 5000 \text{ h}$
- service factor $f_s = 1.3$

Beispiel

Es soll ein lineares Planetengetriebe ausgewählt werden, das unter folgenden Bedingungen zum Einsatz kommt:

- Geschwindigkeit am Eingang $n_1 = 1500 \text{ min}^{-1}$
- verlangte Geschwindigkeit am Ausgang $n_{2r} = 15 \text{ min}^{-1}$
- verlangtes Drehmoment am Ausgang $T_{2r} = 3500 \text{ Nm}$
- verlangte Dauer $h_r = 5000 \text{ h}$
- Betriebsfaktor $f_s = 1.3$



4 SELECTION DES REDUCTEURS

Pour choisir le réducteur qui convient à une application donnée, il faut connaître:

- la vitesse à l'entrée n_1 [min^{-1}];
- la vitesse à la sortie exigée n_{2r} [min^{-1}];
- le couple à la sortie exigé T_{2r} [Nm];
- la durée exigée h_r [h];
- le facteur de service f_s , calculé en fonction du type d'application et des conditions d'utilisation.

A partir de ces données, on détermine le rapport de réduction demandé:

4 SELECCIÓN DE LOS REDUCTORES

Para seleccionar el reductor idóneo para una determinada aplicación es necesario conocer:

- la velocidad en entrada n_1 [min^{-1}];
- la velocidad en salida requerida n_{2r} [min^{-1}];
- el par en salida requerido T_{2r} [Nm];
- la duración requerida h_r [h];
- el factor de servicio f_s , calculado según el tipo de aplicación y las condiciones de uso.

A partir de estos datos se determinan, seguidamente, la relación de reducción requerida:

4 SELEÇÃO DOS REDUTORES

Para a seleção do redutor idóneo para uma dada aplicação é necessário conhecer:

- a velocidade em entrada n_1 [min^{-1}];
- a velocidade em saída necessária n_{2r} [min^{-1}];
- o par em saída necessário T_{2r} [Nm];
- a duração necessária h_r [h];
- de serviço f_s , calculado com base no tipo de aplicação e às condições de emprego.

A partir destes dados determina-se, a relação de redução necessária:

$$i_r = \frac{n_1}{n_{2r}}$$

le couple à la sortie corrigé:

el par en salida corregido:

o par em saída corrigido:

$$T_{2c} = T_{2r} \cdot f_s$$

et le facteur de durée:

y el factor de duración:

e o fator de duração:

$$f_{h,2} = n_{2r} \cdot h_r$$

A partir du tableau des couples nominaux, choisir une grandeur de réducteur ayant un couple nominal supérieur au T_{2c} .

Puis à partir du tableau des caractéristiques techniques, se trouvant au début de la section relative à la grandeur indiquée, choisir un réducteur ayant un rapport de réduction i proche du rapport demandé i_r tout en veillant à ce que le couple applicable à la sortie T_2 soit supérieur au T_{2c} dans la colonne relative à une valeur de n_{2xh} supérieure ou égale au facteur de durée $f_{h,2}$ calculé.

En la tabla de los pares nominales se debe seleccionar una talla de reductor que tenga par nominal mayor que T_{2c} .

Luego, en la tabla de los datos técnicos, presentada al inicio de la sección referente a la talla individuada, se selecciona un reductor que tenga una relación de reducción i próxima a la requerida i_r , comprobando que el par aplicable en salida T_2 sea mayor que T_{2c} en correspondencia con la columna referente a un valor de n_{2xh} mayor o igual que el factor de duración $f_{h,2}$ calculado.

Na tabela dos pares nominais escolher uma grandeza de redutor que tenha par nominal maior do que T_{2c} .

A seguir, da tabela dos dados técnicos, que se encontra no início da seção relativa à grandeza identificada, seleccionar um redutor que tenha relação de redução i próximo àquele necessário i_r , verificando que o par aplicável em saída T_2 seja maior do que T_{2c} em correspondência da coluna relativa a um valor de n_{2xh} maior ou igual ao fator de duração $f_{h,2}$ calculado.

Exemple

Pour choisir un réducteur linéaire pouvant fonctionner aux conditions suivantes:

- vitesse à l'entrée $n_1 = 1500 \text{ min}^{-1}$
- vitesse à la sortie exigée $n_{2r} = 15 \text{ min}^{-1}$
- couple à la sortie exigé $T_{2r} = 3500 \text{ Nm}$
- durée exigée $h_r = 5000 \text{ h}$
- facteur de service $f_s = 1.3$

Ejemplo

Se desea seleccionar un reductor lineal que funcione en las siguientes condiciones:

- velocidad en entrada $n_1 = 1500 \text{ min}^{-1}$
- velocidad en salida requerida $n_{2r} = 15 \text{ min}^{-1}$
- par en salida requerido $T_{2r} = 3500 \text{ Nm}$
- duración requerida $h_r = 5000 \text{ h}$
- factor de servicio $f_s = 1.3$

Exemplo

Deseja-se escolher um redutor linear que funcione às seguintes condições:

- velocidade em entrada $n_1 = 1500 \text{ min}^{-1}$
- velocidade em saída necessária $n_{2r} = 15 \text{ min}^{-1}$
- par em saída necessário $T_{2r} = 3500 \text{ Nm}$
- duração necessária $h_r = 5000 \text{ h}$
- o fator de serviço $f_s = 1.3$

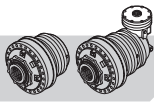

Il rapporto di riduzione richiesto vale:

The reduction ratio required is worth:

Das erforderliche Untersetzungsverhältnis beträgt:

$$i_r = \frac{n_1}{n_{2r}} = \frac{1500}{15} = 100;$$

la coppia corretta è invece:

while the corrected torque is:

Das korrigierte Drehmoment ist:

$$T_{2c} = T_{2r} \cdot f_s = 3500 \cdot 1.3 = 4500 \text{ Nm}$$

mentre il fattore di durata risulta pari a:

and the duration factor is equivalent to:

Der Zeitfaktor entspricht:

$$f_{h,2} = n_{2r} \cdot h_r = 15 \cdot 5000 = 75000$$

Dalla tabella delle coppie nominali si seleziona una grandezza di riduttore che abbia valore di coppia nominale T_{2n} maggiore della T_{2c} ; in questo caso la grandezza idonea è **RR510**.

From the nominal torque table select a reduction gear size which has a nominal torque value T_{2n} greater than T_{2c} ; in this case the suitable size is **RR510**.

Aus der Tabelle mit den Nenndrehmomenten wird eine Größe vom Planetengetriebe ausgewählt, deren Nenndrehmoment T_{2n} größer ist als T_{2c} . In diesem Fall ist die geeignete Größe **RR510**.

Nella tabella delle prestazioni dei riduttori grandezza RR510 è presente un riduttore lineare triplo stadio (T) con rapporto 95.12, prossimo a quello richiesto; in corrispondenza della colonna relativa a

In the technical data table of the RR510 size, there is a triple stage linear reduction gear (T) with a 95.12 ratio, close to what is required; in the column relative to

In der Tabelle mit den Leistungen der Planetengetriebe der Größe RR510 gibt es ein lineares dreistufiges (T) Planetengetriebe mit einem Untersetzungsverhältnis von 95.12, das in etwa dem verlangten Untersetzungsverhältnis entspricht. In der Spalte vom Wert $n_2 \cdot h = 100000 > f_{h,2}$ kann der Wert vom anlegbaren Drehmoment T_2 abgelesen werden, der 4760 Nm entspricht.

$$n_2 \cdot h = 100000 > f_{h,2}$$

$$n_2 \cdot h = 100000 > f_{h,2}$$

si legge il valore della coppia applicabile T_2 che è pari a 4760 Nm.

you can read the value of the applicable torque T_2 which is 4760 Nm.

| i | T_2 [Nm] | | | | | | n_{1max} [min ⁻¹] | T_{2max} [Nm] | P_t [kW] | |
|---------------|-----------------------------|-----------------------------------|---------------------------------|------------------------------|----------------------------------|-------------------------------|------------------------------------|--------------------|-------------------|----|
| | $n_2 \times h$ | | | | | | | | | |
| 1/... | 10000 (10 ⁴) | 25000 (2.5 · 10 ⁴) | 50000 (5 · 10 ⁴) | 100000 (10 ⁵) | 500000 (5 · 10 ⁵) | 1000000 (10 ⁶) | | | | |
| RR510 | 3.40 | 5750 | 5430 | 5290 | 5160 | 4200 | 3410 | 3500 | 7000 (M.../FS) | 21 |
| | 4.00 | 6440 | 5960 | 5360 | 4760 | 4310 | 3810 | | | |
| | 5.00 | 5350 | 4500 | 3960 | 3640 | 3290 | 3160 | | | |
| | 5.80 | 4710 | 3960 | 3480 | 3280 | 2970 | 2840 | | | |
| | 7.00 | 3650 | 3070 | 2720 | 2600 | 2360 | 2260 | | | |
| RR510D | 13.60 | 5750 | 5430 | 5290 | 5160 | 4200 | 3410 | 3500 | 7000 (M.../FS) | 13 |
| | 16.00 | 6440 | 5960 | 5360 | 4760 | 4310 | 3810 | | | |
| | 20.00 | 6440 | 5960 | 5360 | 4760 | 4310 | 3810 | | | |
| | 23.20 | 6440 | 5960 | 5360 | 4760 | 4310 | 3810 | | | |
| | 29.00 | 5350 | 4500 | 3960 | 3640 | 3290 | 3160 | | | |
| | 35.00 | 5350 | 4500 | 3960 | 3640 | 3290 | 3160 | | | |
| | 40.60 | 4710 | 3960 | 3480 | 3280 | 2970 | 2840 | | | |
| | 49.00 | 3650 | 3070 | 2720 | 2600 | 2360 | 2260 | | | |
| RR510T | 65.60 | 6440 | 5960 | 5360 | 4760 | 4310 | 3810 | 3500 | 7000 (M.../FS) | 10 |
| | 82.00 | 6440 | 5960 | 5360 | 4760 | 4310 | 3810 | | | |
| | 95.12 | 6440 | 5960 | 5360 | 4760 | 4310 | 3810 | | | |
| | 115.20 | 6440 | 5960 | 5360 | 4760 | 4310 | 3810 | | | |
| | 144.00 | 6440 | 5960 | 5360 | 4760 | 4310 | 3810 | | | |
| | 167.04 | 6440 | 5960 | 5360 | 4760 | 4310 | 3810 | | | |
| | 208.80 | 5350 | 4500 | 3960 | 3640 | 3290 | 3160 | | | |
| | 252.00 | 5350 | 4500 | 3960 | 3640 | 3290 | 3160 | | | |
| | 292.32 | 4710 | 3960 | 3480 | 3280 | 2970 | 2840 | | | |
| | 352.80 | 3650 | 3070 | 2720 | 2600 | 2360 | 2260 | | | |
| RR510Q | 381.30 | 6440 | 5960 | 5360 | 4760 | 4310 | 3810 | | | |
| | 442.31 | 6440 | 5960 | 5360 | 4760 | 4310 | 3810 | | | |
| | 509.22 | 6440 | 5960 | 5360 | 4760 | 4310 | 3810 | | | |
| | 584.71 | 6440 | 5960 | 5360 | 4760 | 4310 | 3810 | | | |
| | 669.60 | 6440 | 5960 | 5360 | 4760 | 4310 | 3810 | | | |

Poiché questo valore è maggiore della coppia T_{2c} il riduttore selezionato è idoneo per lavorare alle condizioni richieste.

Since this value is greater than torque T_{2c} the reduction gear selected is suitable for working at the conditions required.

Da dieser Wert größer ist als das Drehmoment T_{2c} , eignet sich das ausgewählte Planetengetriebe für den Einsatz unter den verlangten Bedingungen.



Le rapport de réduction demandé vaut:

La relación de reducción requerida vale:

A relação de redução necessária vale

$$i_r = \frac{n_1}{n_{2r}} = \frac{1500}{15} = 100;$$

le couple corrigé est au contraire:

El par corregido es:

por sua vez, o par corrigido é:

$$T_{2c} = T_{2r} \cdot f_s = 3500 \cdot 1.3 = 4500 \text{ Nm}$$

alors que le facteur de durée est égal:

mientras que el factor de duración resulta igual que:

enquanto que o fator de duração resulta equivalente a:

$$f_{h,2} = n_{2r} \cdot h_r = 15 \cdot 5000 = 75000$$

A partir du tableau des couples nominaux, on choisit une grandeur de réducteur ayant une valeur de couple nominal T_{2n} supérieure à T_{2c} ; dans ce cas, la grandeur appropriée est **RR510**.

En la tabla de los pares nominales se selecciona una talla de reductor que tenga valor de par nominal T_{2n} mayor que T_{2c} ; en este caso la talla idónea es **RR510**.

Na tabela dos pares nominais selecciona-se uma grandeza de reductor que tenha valor de par nominal T_{2n} maior de T_{2c} ; neste caso a grandeza idónea é **RR510**.

Sur le tableau des performances des réducteurs grandeur RR510 se trouve un réducteur linéaire à trois étages (T) avec un rapport de 95.12, proche du rapport demandé; en face de la colonne relative à

En la tabla de las prestaciones de los reductores de talla RR510 hay un reductor lineal de triple etapa (T) con relación 95.12, próxima a la requerida; en correspondencia con la columna referente a

Na tabela das prestações dos reductores grandeur RR510 é presente um reductor linear triplo estágio (T) com relação 95.12, próximo àquele necessário; em correspondência da coluna relativa a

$$n_2 \cdot h = 100000 > f_{h,2}$$

$$n_2 \cdot h = 100000 > f_{h,2}$$

$$n_2 \cdot h = 100000 > f_{h,2}$$

on peut lire la valeur du couple applicable T_2 de 4760 Nm.

leemos el valor del par aplicable T_2 que es igual que 4760 Nm.

lê-se o valor do par aplicável T_2 que é igual a 4760 Nm

| i | T_2 [Nm] | | | | | | n_{1max} [min ⁻¹] | T_{2max} [Nm] | P_t [kW] | |
|---------------|-----------------------------|-----------------------------------|---------------------------------|------------------------------|----------------------------------|-------------------------------|------------------------------------|--------------------|-------------------|----|
| | $n_2 \times h$ | | | | | | | | | |
| 1/... | 10000 (10 ⁴) | 25000 (2.5 · 10 ⁴) | 50000 (5 · 10 ⁴) | 100000 (10 ⁵) | 500000 (5 · 10 ⁵) | 1000000 (10 ⁶) | | | | |
| RR510 | 3.40 | 5750 | 5430 | 5290 | 5160 | 4200 | 3410 | 3500 | 7000 (M.../FS) | 21 |
| | 4.00 | 6440 | 5960 | 5360 | 4760 | 4310 | 3810 | | | |
| | 5.00 | 5350 | 4500 | 3960 | 3640 | 3290 | 3160 | | | |
| | 5.80 | 4710 | 3960 | 3480 | 3280 | 2970 | 2840 | | | |
| | 7.00 | 3650 | 3070 | 2720 | 2600 | 2360 | 2260 | | | |
| RR510D | 13.60 | 5750 | 5430 | 5290 | 5160 | 4200 | 3410 | 3500 | 7000 (M.../FS) | 13 |
| | 16.00 | 6440 | 5960 | 5360 | 4760 | 4310 | 3810 | | | |
| | 20.00 | 6440 | 5960 | 5360 | 4760 | 4310 | 3810 | | | |
| | 23.20 | 6440 | 5960 | 5360 | 4760 | 4310 | 3810 | | | |
| | 29.00 | 5350 | 4500 | 3960 | 3640 | 3290 | 3160 | | | |
| | 35.00 | 5350 | 4500 | 3960 | 3640 | 3290 | 3160 | | | |
| | 40.60 | 4710 | 3960 | 3480 | 3280 | 2970 | 2840 | | | |
| | 49.00 | 3650 | 3070 | 2720 | 2600 | 2360 | 2260 | | | |
| RR510T | 65.60 | 6440 | 5960 | 5360 | 4760 | 4310 | 3810 | 3500 | 7000 (M.../FS) | 10 |
| | 82.00 | 6440 | 5960 | 5360 | 4760 | 4310 | 3810 | | | |
| | 95.12 | 6440 | 5960 | 5360 | 4760 | 4310 | 3810 | | | |
| | 115.20 | 6440 | 5960 | 5360 | 4760 | 4310 | 3810 | | | |
| | 144.00 | 6440 | 5960 | 5360 | 4760 | 4310 | 3810 | | | |
| | 167.04 | 6440 | 5960 | 5360 | 4760 | 4310 | 3810 | | | |
| | 208.80 | 5350 | 4500 | 3960 | 3640 | 3290 | 3160 | | | |
| | 252.00 | 5350 | 4500 | 3960 | 3640 | 3290 | 3160 | | | |
| | 292.32 | 4710 | 3960 | 3480 | 3280 | 2970 | 2840 | | | |
| | 352.80 | 3650 | 3070 | 2720 | 2600 | 2360 | 2260 | | | |
| RR510Q | 381.30 | 6440 | 5960 | 5360 | 4760 | 4310 | 3810 | | | |
| | 442.31 | 6440 | 5960 | 5360 | 4760 | 4310 | 3810 | | | |
| | 509.22 | 6440 | 5960 | 5360 | 4760 | 4310 | 3810 | | | |
| | 584.71 | 6440 | 5960 | 5360 | 4760 | 4310 | 3810 | | | |
| | 669.60 | 6440 | 5960 | 5360 | 4760 | 4310 | 3810 | | | |

Cette valeur étant supérieure à la valeur du couple T_{2c} , le réducteur choisi est adapté à un travail dans les conditions requises.

Puesto que este valor es mayor que el par T_{2c} , el reductor seleccionado es idóneo para trabajar en las condiciones requeridas.

Considerando que este valor é maior do par T_{2c} o reductor seleccionado é idóneo para trabalhar às condições necessárias.

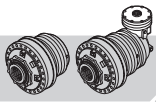

4.1 Funzionamento variabile

4.1 Variable operation

4.1 Variabler Betrieb

Nel caso in cui le condizioni di funzionamento sono variabili, ovvero il riduttore è soggetto ad un ciclo di lavoro con diversi livelli di coppia e/o velocità in uscita, è necessario calcolare la coppia in uscita richiesta equivalente, con la formula:

If operating conditions are variable, that is, the reduction gear is subject to a work cycle with different levels of torque and/or output speeds, you have to calculate the equivalent output torque required with the formula:

Bei variablen Betriebsbedingungen, d.h. dann, wenn das Planetengetriebe einem Arbeitszyklus mit unterschiedlichen Drehmomentstufen u/o Geschwindigkeiten am Ausgang unterliegt, muss das erforderliche äquivalente Drehmoment anhand folgender Formel berechnet werden:

$$T_{2r,eq} = \sqrt[6.7]{\frac{T_{2r,1}^{6.7} \cdot n_{2r,1} \cdot t_1\% + T_{2r,2}^{6.7} \cdot n_{2r,2} \cdot t_2\% + \dots + T_{2r,i}^{6.7} \cdot n_{2r,i} \cdot t_i\%}{n_{2r,1} \cdot t_1\% + n_{2r,2} \cdot t_2\% + \dots + n_{2r,i} \cdot t_i\%}}$$

e la velocità in uscita richiesta equivalente con la formula:

and the equivalent output speed with the formula:

und die erforderliche äquivalente Geschwindigkeit am Ausgang mit folgender Formel:

$$n_{2r,eq} = \frac{n_{2r,1} \cdot t_1\% + n_{2r,2} \cdot t_2\% + \dots + n_{2r,i} \cdot t_i\%}{100\%}$$

essendo $t_1, t_2 \dots t_i$ le percentuali di tempo (sul 100% del ciclo) in cui agiscono le coppie $T_{2r,1}, T_{2r,2} \dots T_{2r,i}$ alle velocità $n_{2r,1}, n_{2r,2} \dots n_{2r,i}$.
Una volta ottenuti i valori di coppia e velocità in uscita equivalenti è possibile procedere con la selezione del riduttore nel modo descritto in precedenza, moltiplicando, se necessario, la coppia in uscita equivalente per il fattore di servizio e calcolando il fattore di durata come prodotto della velocità equivalente per la durata totale richiesta.

*where $t_1, t_2 \dots t_i$ are the percentages of time (on 100% of the cycle) when the torques $T_{2r,1}, T_{2r,2} \dots T_{2r,i}$ act at the speed of $n_{2r,1}, n_{2r,2} \dots n_{2r,i}$.
Once you have the equivalent output speed and torque values, you can then proceed with selecting the reduction gear as described earlier, multiplying, if necessary, the equivalent output torque by the service factor and calculating the duration factor as the product of the equivalent speed by the total duration required.*

wobei $t_1, t_2 \dots t_i$ (auf 100% vom Zyklus) sind, in denen die Drehmomente $T_{2r,1}, T_{2r,2} \dots T_{2r,i}$ mit den Geschwindigkeiten $n_{2r,1}, n_{2r,2} \dots n_{2r,i}$ anliegen.
Nachdem die Werte vom äquivalenten Drehmoment und der äquivalenten Geschwindigkeit am Ausgang berechnet worden sind, kann das Planetengetriebe wie oben beschrieben ausgewählt werden, wobei das äquivalente Ausgangsdrehmoment ggf. mit dem Betriebsfaktor multipliziert und der Zeitfaktor als Produkt von äquivalenter Geschwindigkeit und insgesamt verlangter Dauer berechnet wird.

Esempio

Un riduttore è soggetto al seguente ciclo di lavoro:

Example

A reduction gear is subject to the following work cycle:

Beispiel

Ein Planetengetriebe ist folgendem Arbeitszyklus ausgesetzt:

| Livello Level Stufe | t% | T _{2r} | n _{2r} |
|---------------------------|----|-----------------|-----------------|
| 1 | 10 | 23000 | 10 |
| 2 | 25 | 16500 | 15 |
| 3 | 65 | 10000 | 25 |

La coppia in uscita richiesta equivalente risulta pari a:

The equivalent output torque required is equal to:

Das äquivalente Ausgangsdrehmoment entspricht:

$$T_{2r,eq} = \sqrt[6.7]{\frac{23000^{6.7} \cdot 10 \cdot 10\% + 16500^{6.7} \cdot 15 \cdot 25\% + 10000^{6.7} \cdot 25 \cdot 65\%}{10 \cdot 10\% + 15 \cdot 25\% + 25 \cdot 65\%}} = 15460 \text{ Nm}$$

mentre la velocità in uscita equivalente è:

while the equivalent output speed is equal to:

Die äquivalente Ausgangsgeschwindigkeit entspricht:

$$n_{2r,eq} = \frac{10 \cdot 10\% + 15 \cdot 25\% + 25 \cdot 65\%}{100\%} = 21 \text{ min}^{-1}$$

Da qui in poi si può procedere come visto nell'esempio precedente.

From this point on, you can proceed as for the previous example.

Von hier ab wird wie im oben beschriebenen Beispiel vorgegangen.



4.1 Fonctionnement variable

Si les conditions de fonctionnement sont variables, c'est-à-dire si le réducteur est sujet à un cycle de fonctionnement à plusieurs niveaux de couple et/ou de vitesse à la sortie, il est nécessaire de calculer le couple à la sortie exigé équivalent, en appliquant la formule suivante:

$$T_{2r,eq} = \sqrt[6,7]{\frac{T_{2r,1}^{6,7} \cdot n_{2r,1} \cdot t_1\% + T_{2r,2}^{6,7} \cdot n_{2r,2} \cdot t_2\% + \dots + T_{2r,i}^{6,7} \cdot n_{2r,i} \cdot t_i\%}{n_{2r,1} \cdot t_1\% + n_{2r,2} \cdot t_2\% + \dots + n_{2r,i} \cdot t_i\%}}$$

et la vitesse à la sortie exigée équivalente en employant la formule:

$$n_{2r,eq} = \frac{n_{2r,1} \cdot t_1\% + n_{2r,2} \cdot t_2\% + \dots + n_{2r,i} \cdot t_i\%}{100\%}$$

$t_1, t_2 \dots t_i$ étant les pourcentages de temps (sur 100 % du cycle) où les couples $T_{2r,1}, T_{2r,2} \dots T_{2r,i}$ agissent aux vitesses $n_{2r,1}, n_{2r,2} \dots n_{2r,i}$.

Après avoir obtenu les valeurs de couple et les vitesses à la sortie équivalentes, il est possible de procéder au choix du réducteur suivant les indications précédemment données, en multipliant, si besoin est, le couple à la sortie équivalent pour le facteur de service et en calculant le facteur de durée comme produit de la vitesse équivalente pour la durée totale exigée.

Exemple

Un réducteur est sujet au cycle de fonctionnement suivant:

4.1 Funcionamiento variable

Si las condiciones de funcionamiento son variables, es decir que el reductor está sujeto a un ciclo de trabajo con distintos niveles de par y/o velocidad en salida, es necesario calcular el par en salida requerido equivalente, aplicando la fórmula:

y la velocidad en salida requerida equivalente con la fórmula:

Con $t_1, t_2 \dots t_i$ son los porcentajes de tiempo (sobre el 100% del ciclo) en los cuales actúan los pares $T_{2r,1}, T_{2r,2} \dots T_{2r,i}$ a las velocidades $n_{2r,1}, n_{2r,2} \dots n_{2r,i}$.

Una vez conseguidos los valores de par y velocidad en salida equivalentes, es posible proceder con la selección del reductor de la manera descrita anteriormente, multiplicando, si fuese necesario, el par en salida equivalente por el factor de servicio y calculando el factor de duración como producto de la velocidad equivalente por la duración total requerida.

Ejemplo

Un reductor está sujeto al siguiente ciclo de trabajo:

| Niveau Nivel Nível | t% | T_{2r} | n_{2r} |
|--------------------------|----|----------|----------|
| 1 | 10 | 23000 | 10 |
| 2 | 25 | 16500 | 15 |
| 3 | 65 | 10000 | 25 |

Le couple à la sortie exigé équivalent est égal à:

$$T_{2r,eq} = \sqrt[6,7]{\frac{23000^{6,7} \cdot 10 \cdot 10\% + 16500^{6,7} \cdot 15 \cdot 25\% + 10000^{6,7} \cdot 25 \cdot 65\%}{10 \cdot 10\% + 15 \cdot 25\% + 25 \cdot 65\%}} = 15460 \text{ Nm}$$

alors que la vitesse à la sortie équivalente est:

$$n_{2r,eq} = \frac{10 \cdot 10\% + 15 \cdot 25\% + 25 \cdot 65\%}{100\%} = 21 \text{ min}^{-1}$$

A partir de là, il est possible de procéder comme indiqué dans l'exemple précédent.

4.1 Funcionamento variável

No caso em que as condições de funcionamento sejam variáveis, ou o redutor seja sujeito a um ciclo de trabalho com diversos níveis de par e/ou velocidade em saída, é necessário calcular o par em saída necessário equivalente, com a fórmula:

e a velocidade em saída necessária equivalente com a fórmula:

sendo $t_1, t_2 \dots t_i$ as percentagens de tempo (sobre 100% do ciclo) em que agem ao pares $T_{2r,1}, T_{2r,2} \dots T_{2r,i}$ às velocidades $n_{2r,1}, n_{2r,2} \dots n_{2r,i}$.

Depois de termos obtido os valores de par e velocidade em saída equivalentes é possível proceder com a seleção do reductor no modo descrito precedentemente, multiplicando, se necessário, o par em saída equivalente para o fator de serviço e calculando o fator de duração como produto da velocidade equivalente pela duração total necessária.

Exemplo

Um reductor está sujeito ao seguinte ciclo de trabalho:

El par en salida requerido equivalente resulta ser:

O par em saída necessário equivalente resulta igual a:

mientras que la velocidad en salida equivalente es:

mentre a velocidade em saída equivalente é:

Desde aquí en adelante se puede proceder como visto en el ejemplo precedente.

Daqui para diante pode-se proceder como visto no exemplo precedente.

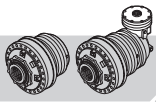

5 VERIFICHE

Una volta selezionato il riduttore in base ai parametri di funzionamento è opportuno procedere con le seguenti verifiche, per garantire la piena compatibilità del riduttore con l'applicazione.

5.1 Verifica della velocità massima in entrata

Il valore della velocità massima in entrata di ciascun riduttore, sia in configurazione lineare sia in configurazione angolare, è riportato nella apposita colonna della tabella dei dati tecnici. In caso di riduttore angolare si raccomanda di non oltrepassare i 1500 min^{-1} in funzionamento continuo, onde evitare un sensibile innalzamento del livello sonoro e un incremento della temperatura dovuta allo sbattimento dell'olio. Se è presente un'entrata veloce si consiglia di non superare i 1500 min^{-1} in condizioni di funzionamento continuo, per non causare notevoli incrementi della temperatura dell'olio. Nel caso di freni negativi si consiglia di non superare le seguenti velocità:

- **RF2** : 1500 min^{-1} ;
- **RF5** : 1000 min^{-1} ;
- **RF170÷290** : 750 min^{-1} .



In generale, quando le condizioni di carico prevedono lunghi periodi di funzionamento a velocità prossima a $n_{1\text{max}}$ o picchi con velocità superiore a $n_{1\text{max}}$, contattare il Servizio Tecnico Reggiana Riduttori.

5.2 Verifica della coppia massima

La coppia massima, cioè il livello di coppia ammesso durante l'avviamento o durante picchi occasionali, non deve mai superare il valore $T_{2\text{max}}$ riportato nella apposita colonna della tabella dei dati tecnici per il riduttore selezionato.

Quando le condizioni di carico prevedono frequenti avviamenti, inversioni del moto o lunghi periodi di funzionamento ad una coppia prossima a $T_{2\text{max}}$ è consigliabile selezionare un riduttore di grandezza superiore.



In presenza di un carico radiale, la coppia massima applicabile subisce una diminuzione.

In questi casi contattare il Servizio Tecnico Reggiana Riduttori per verificare l'idoneità del supporto uscita.

5 CHECKS

Once the reduction gear has been selected based on operating parameters, it is advisable to proceed with the following checks to guarantee complete compatibility of the reduction gear with the application.

5.1 Checking maximum input speed

The value of maximum input speed of each reduction gear, both in the linear and angular configuration, is given in the relative column of the technical data table. For angular reduction gears do not exceed 1500 min^{-1} in continuous operation to avoid a significant increase in the sound level and in the temperature due to oil splash. In the case of a fast input, we recommend not exceeding 1500 min^{-1} in continuous operating conditions so as not to overheat the oil. In the case of negative brakes, we recommend not to exceed the following speeds:

- **RF2** : 1500 min^{-1} ;
- **RF5** : 1000 min^{-1} ;
- **RF170÷290** : 750 min^{-1} .

In general, when load conditions entail long periods of operation at a speed close to $n_{1\text{max}}$ or peaks with speed higher than $n_{1\text{max}}$, contact the Reggiana Riduttori Technical Service.

5.2 Checking maximum torque

Maximum torque, that is, the level of torque permitted during start-up or occasional peaks, must never exceed $T_{2\text{max}}$ which is given in the relative column in the technical data table for the reduction gear selected.

When load conditions entail frequent start-ups, direction reversals or long periods of operation at a torque close to $T_{2\text{max}}$ it is advisable to select a bigger size reduction gear.

In the case of a radial load the maximum applicable torque is reduced. In these cases contact the Reggiana Riduttori Technical Service to verify the suitability of the output support.

5 KONTROLLEN

Nachdem das Planetengetriebe anhand der Betriebsparameter ausgewählt worden ist, sollten folgende Kontrollen durchgeführt werden, um die volle Kompatibilität vom Planetengetriebe mit der Anwendung zu garantieren.

5.1 Kontrolle der maximalen Eingangsgeschwindigkeit

Der Wert der maximalen Eingangsgeschwindigkeit von jedem Planetengetriebe mit linearer Konfiguration oder mit Winkelkonfiguration ist in der entsprechenden Spalte der Tabelle mit den technischen Daten angegeben. Bei Planetengetrieben mit Winkelkonfiguration wird dazu geraten, den Wert von 1500 min^{-1} bei Dauerbetrieb nicht zu überschreiten, um ein deutliches Ansteigen vom Schallpegel und eine Zunahme der Temperatur durch das Schlagen vom Öl zu vermeiden. Wenn ein schneller Eingang vorhanden ist, wird dazu geraten, den Wert von 1500 min^{-1} bei Dauerbetrieb nicht zu übersteigen, da es sonst zu einem beachtlichen Anstieg der Öltemperatur kommen kann. Im Fall von Negativbremsen sollten folgende Geschwindigkeiten nicht übersteigen werden:

- **RF2** : 1500 min^{-1} ;
- **RF5** : 1000 min^{-1} ;
- **RF170÷290** : 750 min^{-1} .

Bei Belastungsbedingungen, die lange Betriebszeiten mit einer Geschwindigkeit von etwa $n_{1\text{max}}$ oder Spitzen mit einer Geschwindigkeit von $n_{1\text{max}}$ vorsehen, bitte Rücksprache mit dem Technischen Kundendienst von Reggiana Riduttori halten.

5.2 Kontrolle vom maximalen Drehmoment

Das maximale Drehmoment, d.h. das Drehmoment, das beim Anlaufen oder bei gelegentlichen Spitzen zugelassen ist, darf auf keinen Fall den Wert $T_{2\text{max}}$ übersteigen, der in der entsprechenden Spalte der Tabelle mit den technischen Daten vom ausgewählten Planetengetriebe angegeben ist.

Wenn die Belastungsbedingungen ein häufiges Starten, häufige Umkehrungen der Laufbewegung oder lange Betriebszeiten mit einem Drehmoment von $T_{2\text{max}}$ vorsehen, sollte ein größer ausgelegtes Planetengetriebe gewählt werden.

Bei Vorhandensein einer Querlast verringert sich das maximal anlegbare Drehmoment. In diesem Fall bitte mit dem Technischen Kundendienst von Reggiana Riduttori Rücksprache halten, um die Eignung vom Lager am Ausgang zu prüfen.

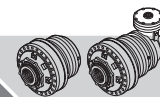

5 CONTROLES

Après avoir choisi le réducteur suivant les paramètres de fonctionnement, il convient de procéder aux contrôles suivants, pour s'assurer que le réducteur est parfaitement compatible avec l'application.

5.1 Contrôle de la vitesse maximum à l'entrée

La valeur de la vitesse maximum à l'entrée de chaque réducteur, aussi bien en configuration linéaire qu'en configuration angulaire, figure dans la colonne correspondante du tableau des caractéristiques techniques. En cas de réducteur angulaire, il est recommandé de ne pas dépasser 1500 min^{-1} en service continu, afin d'éviter une augmentation importante des nuisances sonores et une hausse de la température, due au barbotage de l'huile. Si une entrée rapide est présente, il est conseillé de ne pas dépasser 1500 min^{-1} dans des conditions de service continu, pour ne pas provoquer de hausses de la température de l'huile. En cas de freins négatifs, il est conseillé de ne pas dépasser les vitesses suivantes:

- **RF2** : 1500 min^{-1} ;
- **RF5** : 1000 min^{-1} ;
- **RF170÷290** : 750 min^{-1} .



En général, quand les conditions de charge prévoient de longues périodes de fonctionnement à une vitesse proche de $n_{1\text{max}}$ ou des pics à une vitesse supérieure à $n_{1\text{max}}$, contacter le service technique Reggiana Riduttori.

5.2 Contrôles du couple maximum

Le couple maximum, c'est-à-dire le niveau de couple admis au cours du démarrage ou au moment des pics occasionnels, ne doit jamais dépasser la valeur $T_{2\text{max}}$ figurant dans la colonne du tableau des caractéristiques techniques pour le réducteur choisi. Quand les conditions de charge prévoient des démarrages fréquents, des inversions du mouvement ou de longues périodes de fonctionnement à un couple proche de $T_{2\text{max}}$, il est conseillé de choisir un réducteur de grandeur supérieure.



En présence d'une charge radiale, le couple maximum applicable subit une diminution. Dans ces cas, contacter le service technique Reggiana Riduttori pour vérifier l'adéquation du support à la sortie.

5 COMPROBACIONES

Una vez seleccionado el reductor sobre la base de los parámetros de funcionamiento, es oportuno proceder con las siguientes comprobaciones, para garantizar la plena compatibilidad del reductor con la aplicación.

5.1 Comprobación de la velocidad máxima en entrada

El valor de la velocidad máxima en entrada de cada reductor, tanto en configuración lineal como en configuración angular, se presenta en la correspondiente columna de la tabla de los datos técnicos. En caso de reductor angular, se recomienda no superar las 1500 min^{-1} en funcionamiento continuo, a fin de evitar un aumento notable del nivel sonoro y un aumento de la temperatura debido a la agitación del aceite. Si hay presente una entrada rápida, se aconseja no superar las 1500 min^{-1} en condiciones de funcionamiento continuo, para no causar notables aumentos de la temperatura del aceite. En el caso de frenos negativos, se aconseja no superar las siguientes velocidades .

- **RF2** : 1500 min^{-1} ;
- **RF5** : 1000 min^{-1} ;
- **RF170÷290** : 750 min^{-1} .

En general, cuando las condiciones de carga prevén largos periodos de funcionamiento a velocidad próxima a $n_{1\text{max}}$ o picos con velocidad mayor que $n_{1\text{max}}$, contactar con el Servicio Técnico de Reggiana Riduttori.

5.2 Comprobación del par máximo

El par máximo, es decir el nivel de par admitido durante el arranque o durante picos ocasionales, no debe superar nunca el valor $T_{2\text{max}}$ presentado en la correspondiente columna de la tabla de los datos técnicos para el reductor seleccionado.

Cuando las condiciones de carga prevén frecuentes arranques, inversiones de la marcha o largos periodos de funcionamiento con un par próximo a $T_{2\text{max}}$ se aconseja seleccionar un reductor de talla superior.

En presencia de una carga radial, el par máximo aplicable sufre una disminución. En estos casos cabe contactar con el Servicio Técnico de Reggiana Riduttori para comprobar la idoneidad del soporte de salida.

5 VERIFICAÇÕES

Depois de termos seleccionado o redutor com base nos parâmetros de funcionamento é oportuno proceder com as seguintes verificações, para garantir a plena compatibilidade do redutor com a aplicação.

5.1 Verificação da velocidade máxima em entrada

O valor da velocidade máxima em entrada de cada redutor, seja em configuração linear seja em configuração angular, é indicado na respetiva coluna da tabela dos dados técnicos. No caso de redutor angular recomendamos de não ultrapassar os 1500 min^{-1} em funcionamento contínuo, para evitar um sensível aumento do nível sonoro e um incremento da temperatura devida ao batimento do óleo. Se se encontra presente uma entrada rápida aconselhamos não superar os 1500 min^{-1} em condições de funcionamento contínuo, para não provocar notáveis aumentos da temperatura do óleo. No caso de freios negativos aconselhamos não superar as seguintes velocidades:

- **RF2** : 1500 min^{-1} ;
- **RF5** : 1000 min^{-1} ;
- **RF170÷290** : 750 min^{-1} .

Em geral, quando as condições de carga prevêem longos períodos de funcionamento a velocidade próxima a $n_{1\text{max}}$ ou picos com velocidade superior a $n_{1\text{max}}$, contatar o Serviço Técnico Reggiana Riduttori.

5.2 Verificação do par máximo

O par máximo, ou seja o nível de par admitido durante o início de funcionamento ou durante picos ocasionais, nunca se deve superar o valor $T_{2\text{max}}$ indicado na respetiva coluna da tabela dos dados técnicos do redutor seleccionado.

Quando as condições de carga prevêem frequentes inícios de funcionamento, inversões do movimento ou longos períodos de funcionamento a um par próximo a $T_{2\text{max}}$ é aconselhável seleccionar um redutor de grandeza superior.

Em presença de uma carga radial, o par máximo aplicável sofre uma diminuição. Nestes casos contatar o Serviço Técnico Reggiana Riduttori para verificar a idoneidade do suporte saída.

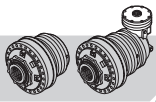

5.3 Verifica dei carichi radiali e assiali

Nel caso in cui sia presente un carico radiale sull'albero uscita occorre verificare che questo non sia superiore al valore massimo applicabile (funzione dell'ascissa x), per il fattore di durata richiesto.

Le curve dei carichi radiali sono riportate all'interno delle sezioni relative a ciascuna grandezza di riduttore, in base al tipo di supporto uscita.

Se il fattore di durata richiesto $f_{h,2}$ è diverso da 10^5 (valore in base al quale sono state ottenute le curve) occorre moltiplicare il carico massimo applicabile per un coefficiente correttivo $k_{r,2}$, che si ricava dalle apposite curve.

Qualora il carico radiale che si intende applicare risulti superiore a quello applicabile, occorre passare alla grandezza superiore di riduttore.

Volendo calcolare il fattore di durata conseguente all'applicazione di un carico radiale $F_{r,2}$ nella posizione x occorre calcolare $k_{r,2}$ come rapporto tra carico applicato e carico massimo applicabile in x (ricavato dalla curva relativa al supporto uscita considerato); entrando con questo valore sulla curva che fornisce $k_{r,2}$ in funzione del fattore di durata è possibile ricavare la durata del supporto uscita in termini di $n_2 \cdot h$.



Nel caso di presenza simultanea di carichi radiali e assiali occorre verificare l'idoneità del supporto uscita contattando il Servizio Tecnico Reggiana Riduttori.

Allo stesso modo se è presente un carico radiale in ingresso bisogna verificare che questo non sia superiore a quello massimo ammissibile riportato sulla curva corrispondente al tipo di entrata veloce applicata al riduttore. Anche in questo caso se il fattore di durata in ingresso $k_{r,1}$ è diverso da 10^7 (valore in base al quale sono state ottenute le curve) occorre correggere il valore ricavato dalla curva del carico radiale mediante il fattore $k_{r,1}$ che si ricava dalle apposite curve.

5.3 Checking radial and axial loads

If there is a radial load on the output shaft you need to verify that it is no higher than the maximum applicable value (abscissa x function) for the duration factor required.

The curves of the radial loads are given in the sections relative to each reduction gear size, based on the type of output support.

If the duration factor required $f_{h,2}$ is different from 10^5 (value on the basis of which the curves are obtained) you have to multiply the maximum applicable load by a corrective coefficient $k_{r,2}$, which is found by way of the relative curves.

If the radial load you intend applying is greater than the applicable load, you have to go to the next higher size reduction gear.

Wanting to calculate the duration factor consequential to the application of a radial load $F_{r,2}$ in position x , $k_{r,2}$ has to be calculated as the ratio between the applied load and the maximum applicable load in x (gleaned from the curve relative to the output support considered); entering with this value on the curve that provides $k_{r,2}$ as a function of the duration factor, it is possible to find the duration of the output support in terms of $n_2 \cdot h$.

If we have radial and axial loads simultaneously, it is necessary to verify the suitability of the output support contacting the Reggiana Riduttori Technical Service.

In the same way, if there is a radial load in input you have to verify that it is no higher than the maximum applicable one shown on the curve corresponding to the type of fast input applied to the reduction gear. Also in this case, if the duration factor in input $k_{r,1}$ is different from 10^7 (value on the basis of which the curves are obtained) it is necessary to correct the value gleaned from the radial load curve by means of factor $k_{r,1}$ which is gleaned from the relative curves.

5.3 Kontrolle von Querlasten und Achslasten

Sollte eine Querlast auf die Ausgangswelle einwirken, muss sichergestellt werden, dass die Querlast für den verlangten Zeitfaktor nicht den maximal anlegbaren Wert (Funktion der X-Koordinate) übersteigt.

Die Kurven der Querlasten sind in den Abschnitten der einzelnen Planetengetriebe angegeben, je nach Ausgangslager.

Wenn ein anderer Zeitfaktor $f_{h,2}$ als 10^5 verlangt wird (Wert, anhand dessen die Kurven berechnet wurden), muss die maximal anlegbare Last mit einem Korrektorkoeffizienten $k_{r,2}$ multipliziert werden, der den entsprechenden Kurven entnommen werden kann.

Sollte die Querlast, die angelegt werden soll, größer sein als der Wert der maximal anlegbaren Querlast, muss ein größeres ausgelegtes Planetengetriebe. Wenn der Zeitfaktor für das Einwirken einer Querlast $F_{r,2}$ in Position x berechnet werden soll, muss $k_{r,2}$ als das Verhältnis von anliegender Last und maximal anlegbarer Last in Punkt x berechnet werden (welche der Kurve vom berücksichtigten Ausgangslager entnommen werden kann). Mit diesem Wert kann dann anhand der Kurve von $k_{r,2}$ in Abhängigkeit vom Zeitfaktor die Dauer vom Ausgangslager als $n_2 \cdot h$ abgeleitet werden.

Sollten gleichzeitig Querlasten und Achslasten anliegen, bitte Rücksprache mit dem Technischen Kundendienst von Reggiana Riduttori halten, um die Eignung vom Ausgangslager zu prüfen.

Die gleichen Überlegungen gelten für den Fall, dass am Eingang eine Querlast anliegt. Auch hier muss sichergestellt werden, dass diese nicht die maximal zulässige Last übersteigt, die der Kurve vom Typ der schnellen Eingangs entnommen werden kann, welcher am Planetengetriebe montiert ist. Wenn sich der Zeitfaktor am Eingang $k_{r,1}$ von 10^7 (Wert, anhand dessen die Kurven berechnet wurden) unterscheidet, muss auch in diesem Fall der Wert, der der Querlastkurve entnommen worden ist, mit dem Faktor $k_{r,1}$ korrigiert werden, der den entsprechenden Kurven entnommen werden kann.

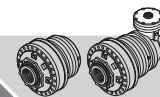

5.3 Contrôle des charges radiales et axiales

En présence d'une charge radiale sur l'arbre à la sortie, veiller à ce qu'elle ne soit pas supérieure à la valeur maximum applicable (fonction de l'abscisse x), pour le facteur de durée exigé.

Les courbes des charges radiales sont indiquées dans les sections relatives à chaque grandeur de réducteur, suivant le support à la sortie.

Si le facteur de durée exigé $f_{h,2}$ est différent de 10^5 (valeur en fonction de laquelle les courbes ont été obtenues) il faut multiplier la charge maximum applicable par un coefficient correctif $k_{r,2}$, qu'on prend des courbes correspondantes.

Si la charge radiale qu'on veut appliquer est supérieure à la charge applicable, il faut passer à la grandeur supérieure de réducteur.

Si l'on veut calculer le facteur de durée consécutif à l'application d'une charge radiale $F_{r,2}$ dans la position x , il faut calculer $k_{r,2}$ comme rapport entre charge appliquée et charge maximum applicable en x (pris de la courbe relative au support à la sortie pris en considération); en entrant avec cette valeur sur la courbe qui fournit $k_{r,2}$ en fonction du facteur de durée, il est possible de trouver la durée du support à la sortie en termes de $n_2 \cdot h$.



En cas de présence simultanée de charges radiales et axiales, vérifier l'adéquation du support à la sortie en contactant le service technique Reggiana Riduttori.

De la même manière, si une charge radiale est présente à l'entrée, il faut veiller à ce qu'elle ne dépasse la charge maximum admissible indiquée sur la courbe correspondant au type d'entrée rapide appliquée au réducteur. Dans ce cas également, si le facteur de durée à l'entrée $k_{r,1}$ est différent de 10^7 (valeur selon laquelle on a obtenu les courbes) il faut corriger la valeur trouvée à partir de la courbe de la charge radiale par l'intermédiaire du facteur $k_{r,1}$ qu'on obtient à partir des courbes correspondantes.

5.3 Comprobación de las cargas radiales y axiales

Si hay presente una carga radial sobre el eje de salida, cabe comprobar que no supere el valor máximo aplicable (función de la abscisa x), por el factor de duración requerido.

Las curvas de las cargas radiales se indican dentro de las secciones correspondientes a cada talla de reductor, según el tipo de soporte de salida.

Si el factor de duración requerido $f_{h,2}$ es distinto de 10^5 (valor sobre la base del cual se han obtenido las curvas) es necesario multiplicar la carga máxima aplicable por un coeficiente de corrección $k_{r,2}$, que se saca de las curvas correspondientes.

Si la carga radial que se desea aplicar resulta ser mayor que la aplicable, es necesario pasar a la talla superior de reductor.

Deseando calcular el factor de duración consiguiente a la aplicación de una carga radial $F_{r,2}$ en la posición x es necesario calcular $k_{r,2}$ como relación entre carga aplicada y carga máxima aplicable en x (sacado de la curva correspondiente al soporte de salida considerado); entrando con este valor en la curva que proporciona $k_{r,2}$ en función del factor de duración es posible sacar la duración del soporte de salida en términos de $n_2 \cdot h$.

En caso de presencia simultánea de cargas radiales y axiales, es necesario comprobar la idoneidad del soporte de salida contactando con el Servicio Técnico de Reggiana Riduttori.

De la misma manera, si hay presente una carga radial en entrada es necesario comprobar que ésta no supere la máxima admitida, indicada en la curva correspondiente al tipo de entrada rápida aplicada al reductor. También en este caso si el factor de duración en entrada $k_{r,1}$ es distinto de 10^7 (valor sobre la base del cual se han conseguido las curvas) es necesario corregir el valor sacado de la curva de la carga radial mediante el factor $k_{r,1}$ que se saca de las curvas correspondientes.

5.3 Verificação das cargas radiais e axiais

No caso em que se encontre presente uma carga radial no eixo de saída é necessário verificar que esta não seja superior ao valor máximo aplicável (função da abscissa x), para o fator de duração necessário.

As curvas das cargas radiais estão indicadas no interior das seções relativas a cada grandezza de reductor, segundo o tipo de suporte saída.

Se o fator de duração necessário $f_{h,2}$ é diverso de 10^5 (valor segundo o qual foram obtidas as curvas) é necessário multiplicar a carga máxima aplicável por um coeficiente corretivo $k_{r,2}$, que se obtém nas respetivas curvas.

No caso em que a carga radial que se deseja aplicar resulte superior àquela aplicável, é necessário passar à grandezza superior de reductor.

Desejando calcular o fator de duração consequente à aplicação de uma carga radial $F_{r,2}$ na posição x é necessário calcular $k_{r,2}$ como relação entre a carga aplicada e carga máxima aplicável em x (obtida na curva relativa ao suporte saída considerado); entrando com este valor na curva que fornece $k_{r,2}$ em função do fator de duração é possível obter a duração do suporte saída em termos de $n_2 \cdot h$.

No caso de presença simultânea de cargas radiais e axiais é necessário verificar a idoneidade do suporte saída contactando o Serviço Técnico Reggiana Riduttori.

Do mesmo modo, se se encontra presente uma carga radial em entrada é preciso verificar que a mesma não seja superior àquela máxima admissível indicada na curva correspondente ao tipo de entrada veloz aplicada ao reductor. Também neste caso se o fator de duração em entrada $k_{r,1}$ é diverso de 10^7 (valor segundo o qual foram obtidas as curvas) é necessário corrigir o valor obtido da curva da carga radial mediante o fator $k_{r,1}$ que se obtém nas respetivas curvas.

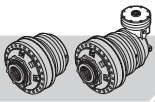

Esempio 1

Nota la posizione del carico radiale $x=45\text{mm}$ e il fattore di durata richiesto $n_2 \cdot h = 500000$, si vuole conoscere il carico radiale $F_{r,2}$ applicabile sull'albero uscita del riduttore RR510 MS.

Example 1

Knowing the position of the radial load $x=45\text{mm}$ and the duration factor required $n_2 \cdot h = 500000$, we want to know the radial load $F_{r,2}$ that can be applied on the output shaft of the RR510 MS reduction gear.

Beispiel 1

Bei einer Position der Achslast $x=45\text{mm}$ und einem verlangten Zeitfaktor von $n_2 \cdot h = 500000$, soll die Querlast $F_{r,2}$ ermittelt werden, die an der Ausgangswelle vom Planetengetriebe RR510 MS angelegt werden kann.

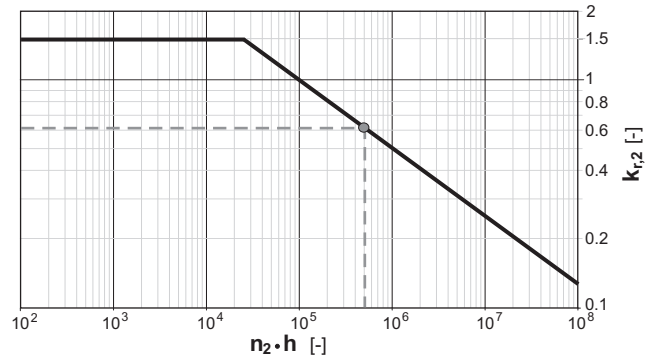
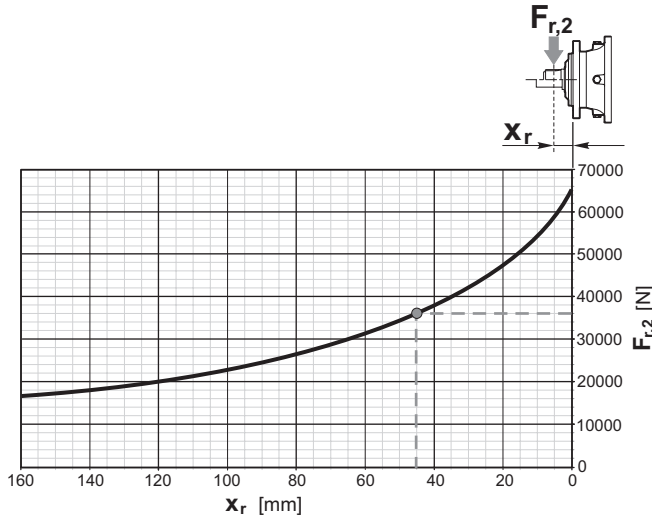

Dal grafico del carico radiale si ricava il valore nominale applicabile a 45 mm, pari a 36000 N. Questo valore deve essere corretto attraverso il fattore $k_{r,2}$ per tenere conto del fattore di durata diverso da 10^5 ; dal secondo grafico, in corrispondenza dell'ascissa $n_2 \cdot h = 500000$ si ricava il valore di $k_{r,2}$ cercato, pari a 0.62.

In the radial load graph we can find the nominal applicable value at 45 mm, equal to 36000 N. This value has to be corrected by means of factor $k_{r,2}$ in order to take into account the duration factor different from 10^5 ; in the second graph, where the abscissa $n_2 \cdot h = 500000$ is, we can find the $k_{r,2}$ value we are looking for, equal to 0.62.

Aus der Querlastkurve wird der bei 45 mm anlegbare Nennwert ermittelt, der 36000 N entspricht. Dieser Wert muss mit dem Faktor $k_{r,2}$ korrigiert werden, um den von 10^5 abweichenden Zeitfaktor zu berücksichtigen. Aus der zweiten Kurve kann auf Höhe der X-Koordinate $n_2 \cdot h = 500000$ der gesuchte Wert $k_{r,2}$ entnommen werden, der 0.62 entspricht.

Dunque il carico radiale massimo che è possibile applicare in posizione x è pari a:

So, the maximum radial load that can be applied in position x is equal to:

In Position x kann also eine maximale Querlast mit folgendem Wert angelegt werden:

$$F_{r,2} = F_{r,2nom} \cdot k_{r,2} = 36000 \cdot 0.62 = 22320 \text{ N}$$

Esempio 2

Nota la posizione del carico radiale $x=45\text{ mm}$ ed il suo valore $F_{r,2} = 30000\text{ N}$, si vuole determinare il fattore di durata del supporto uscita per il riduttore RR510 MS.

Example 2

Knowing the position of the radial load $x=45\text{ mm}$ and its $F_{r,2} = 30000\text{ N}$ value, we want to know the output support's duration factor for the RR510 MS reduction gear.

Beispiel 2

Bei einer Position der Achslast $x=45\text{ mm}$ und deren Wert $F_{r,2} = 30000\text{ N}$ soll der Zeitfaktor vom Ausgangslager für das Planetengetriebe RR510 MS ermittelt werden.

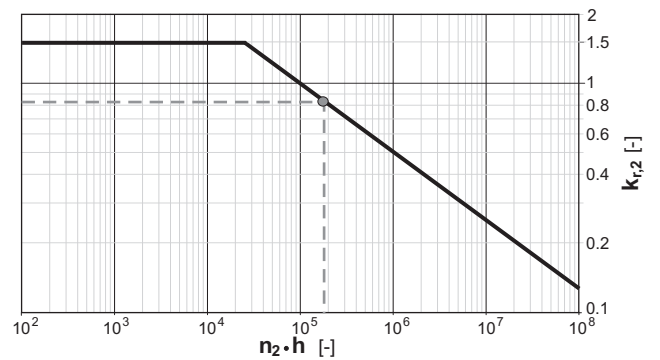
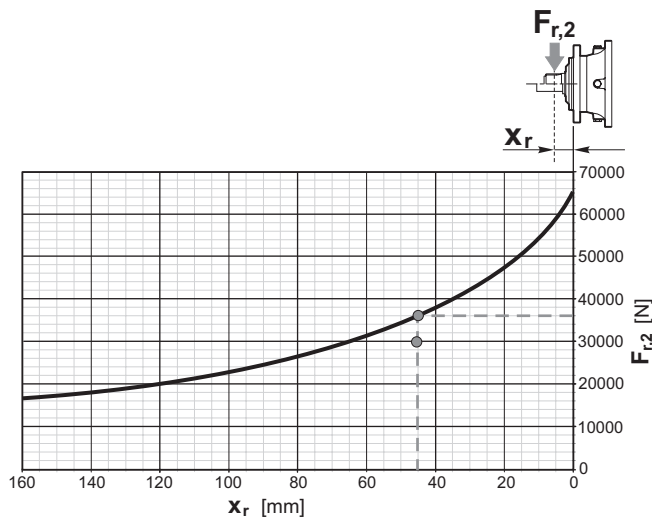

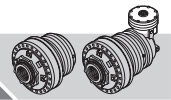

Exemple 1

Connaissant la position de la charge radiale $x = 45\text{mm}$ et le facteur de durée exigé $n_2 \cdot h = 500000$, on cherche la charge radiale $F_{r,2}$ applicable sur l'arbre à la sortie du réducteur RR510 MS.

Ejemplo 1

Conocida la posición de la carga radial $x=45\text{mm}$ y el factor de duración requerido $n_2 \cdot h = 500000$, se desea conocer la carga radial $F_{r,2}$ aplicable sobre el eje de salida del reductor RR510 MS.

Exemplo 1

Conhecida a posição da carga radial $x = 45\text{mm}$ e o fator de duração necessário $n_2 \cdot h = 500000$, deseja-se conhecer a carga radial $F_{r,2}$ aplicável no eixo saída do redutor RR510 MS.

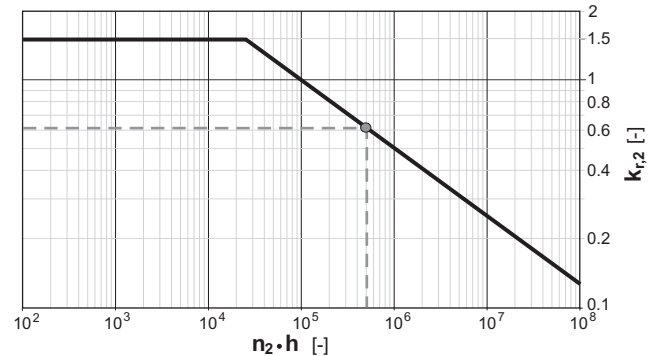
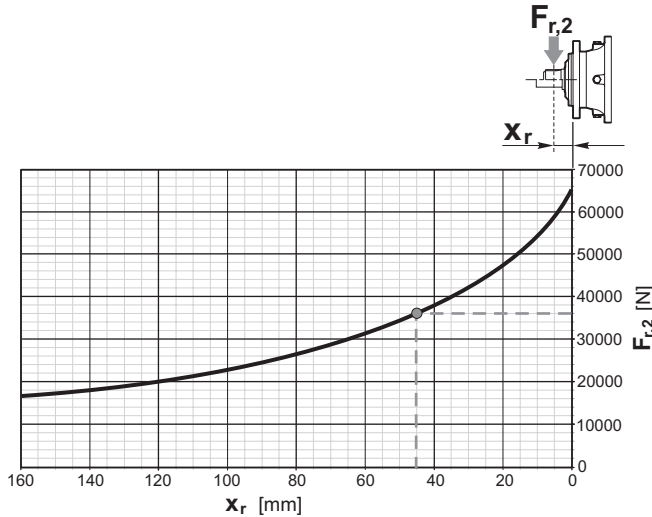

A partir du graphique de la charge radiale, on obtient la valeur nominale applicable à 45 mm, égale à 36000 N. Cette valeur doit être corrigée par le facteur $k_{r,2}$ pour tenir compte du facteur de durée différent de 10^5 ; à partir du deuxième graphique, à la hauteur de l'abscisse, $n_2 \cdot h = 500000$, on trouve la valeur de $k_{r,2}$ cherchée, égale à 0.62.
La charge radiale maximum qu'il est possible d'appliquer en position x est donc égale à :

Del gráfico de la carga radial se saca el valor nominal aplicable a 45 mm, que vale 36000N. Este valor se debe corregir a través del factor $k_{r,2}$ para tener en cuenta el factor de duración distinto de 10^5 ; del segundo gráfico, en correspondencia con la abscisa, $n_2 \cdot h = 500000$, se saca el valor de $k_{r,2}$ buscado, que vale 0.62.
Por lo tanto, la carga radial máxima que es posible aplicar en la posición x es:

Da gráfico da carga radial obtém-se o valor nominal aplicável a 45 mm, equivalente a 36000 N. Este valor deve ser corrigido através do fator $k_{r,2}$ para considerar o fator de duração diferente de 10^5 ; do segundo gráfico, em correspondência da abscissa $n_2 \cdot h = 500000$, obtém-se o valor de $k_{r,2}$ procurado, equivalente a 0.62.
Portanto, a carga radial máxima que é possível aplicar na posição x é igual a :

$$F_{r,2} = F_{r,2nom} \cdot k_{r,2} = 36000 \cdot 0.62 = 22320 \text{ N}$$

Exemple 2

Connaissant la position de la charge radiale $x=45\text{ mm}$ et sa valeur $F_{r,2}=30000 \text{ N}$, on cherche le facteur de durée du support à la sortie pour le réducteur RR510 MS.

Ejemplo 2

Conocida la posición de la carga radial $x=45\text{ mm}$ y su valor $F_{r,2}=30000 \text{ N}$, se desea determinar el factor de duración del soporte de salida para el reductor RR510 MS.

Exemplo 2

Conhecida a posição da carga radial $x= 45\text{ mm}$ e o seu valor $F_{r,2} = 30000 \text{ N}$, deseja-se calcular o fator de duração do suporte saída para o redutor RR510 MS.

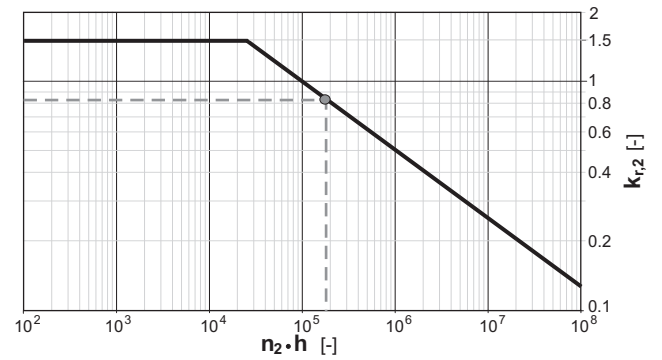
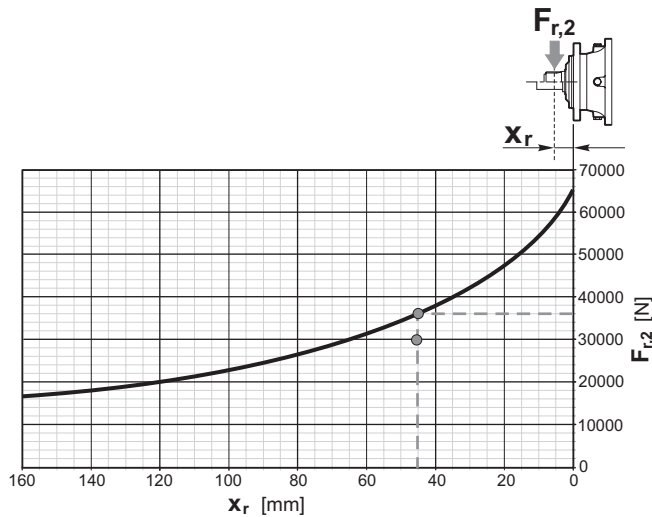

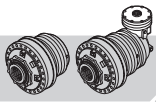

Dal rapporto tra il carico nominale applicabile in x, pari a 36000N, ed il carico applicato si ottiene il fattore correttivo $k_{r,2}$:

From the ratio between the nominal load applicable in x, equal to 36000N, and the load applied, we have the corrective coefficient $k_{r,2}$:

Aus dem Verhältnis von anlegbarer Nennlast in x, die 36000N entspricht, und angelegter Last erhält man den Korrekturfaktor $k_{r,2}$:

$$k_{r,2} = \frac{F_{r,2}}{F_{r,2nom}} = \frac{30000}{36000} = 0.83$$

Nel grafico del fattore correttivo, in corrispondenza di questo valore di $k_{r,2}$ si trova un valore del fattore di durata, pari a circa 200000 $n_2 \cdot h$.

In the corrective coefficient graph, where we find the $k_{r,2}$ value, we find a value of the duration factor which is equivalent to about 200000 $n_2 \cdot h$.

In der Kurve vom Korrekturfaktor kann auf Höhe von diesem Wert $k_{r,2}$ der Wert vom Zeitfaktor abgelesen werden, der ca. 200000 $n_2 \cdot h$ entspricht.

5.4 Verifica della potenza termica

5.4 Checking thermal power

5.4 Kontrolle der Wärmeleistung

Se la potenza trasmessa dal riduttore, ossia la potenza richiesta in entrata P_{r1} , è superiore alla potenza termica P_t è necessario predisporre un sistema di raffreddamento ausiliario. Poiché il valore della potenza termica dei riduttori è calcolato nell'ipotesi di $t_a=20^\circ\text{C}$ e $n_1=1000 \text{ min}^{-1}$, quando le reali condizioni di funzionamento si discostano da questa condizione è necessario correggere il valore di P_t mediante i fattori K_t , fattore di temperatura, e K_v , fattore di velocità, ricavabili dalle tabelle che seguono:

If the power transmitted by the reduction gear, that is, the power required in input P_{r1} , is higher than thermal power P_t an auxiliary cooling system is necessary. Since the value of the reduction gears' thermal power is calculated hypothesising $t_a=20^\circ\text{C}$ and $n_1=1000 \text{ min}^{-1}$, when the actual operating conditions deviate from this condition the P_t value has to be corrected by means of the K_t factors, the temperature factor, and K_v , and the speed factor which can be found in the following tables:

Wenn die vom Planetengetriebe übertragene Leistung, d.h. die am Eingang verlangte Leistung P_{r1} größer ist als die Wärmeleistung P_t , muss ein zusätzliches Kühlsystem vorgesehen werden. Da der Wert der Wärmeleistung der Planetengetriebe unter der Annahme berechnet wird, dass $t_a=20^\circ\text{C}$ und $n_1=1000 \text{ min}^{-1}$, muss der Wert P_t bei Abweichung von diesen Bedingungen mit dem Temperaturfaktor K_t und dem Geschwindigkeitsfaktor K_v korrigiert werden, die den Tabellen unten entnommen werden können:

| K_t | minuti di funzionamento / ora minutes operating/hour Minuten Betrieb/pro Stunde | | t_a | | | | | |
|---|---|------|-------|------|------|------|------|------|
| | | | 10°C | 20°C | 30°C | 40°C | 50°C | 60°C |
| Servizio continuo Continuous duty Dauerbetrieb | 60 | 100% | 0.9 | 1 | 1.15 | 1.4 | 1.75 | 2.35 |
| | 48 | 80% | 0.8 | 0.9 | 1.05 | 1.25 | 1.55 | 2.1 |
| Servizio intermittente Intermittent duty Aussetzbetrieb | 36 | 60% | 0.7 | 0.8 | 0.95 | 1.1 | 1.4 | 1.85 |
| | 24 | 40% | 0.6 | 0.7 | 0.8 | 0.95 | 1.2 | 1.6 |
| | 12 | 20% | 0.5 | 0.6 | 0.7 | 0.8 | 1.05 | 1.35 |

| n_1 [min ⁻¹] | K_v |
|----------------------------|-------|
| 500 | 1.08 |
| 750 | 1.04 |
| 1000 | 1.00 |
| 1250 | 0.95 |
| 1500 | 0.89 |
| 1750 | 0.82 |
| 2000 | 0.75 |
| 2250 | 0.66 |
| 2500 | 0.59 |
| 2750 | 0.54 |
| 3000 | 0.48 |

La potenza termica corretta P'_t si calcola con la formula:

The corrected thermal power P'_t is calculated with the formula:

Die korrigierte Wärmeleistung P'_t wird anhand folgender Formel berechnet:

$$P'_t = \frac{P_t \cdot K_v}{K_t}$$

Se risulta $P_{r1} > P'_t$ occorre installare un sistema ausiliario di raffreddamento per smaltire la potenza termica in eccesso, ricavabile dalla formula:

If the result is $P_{r1} > P'_t$ an auxiliary cooling system has to be installed to get rid of the thermal power in excess, found with the formula:

Wenn $P_{r1} > P'_t$ muss ein zusätzliches Kühlsystem installiert werden, um die übermäßige Wärmeleistung abzuleiten, die anhand folgender Formel berechnet werden kann:

$$P_s = \frac{(P_{r1} - P'_t) \cdot C_{rt}}{860}$$

in cui C_{rt} è un coefficiente che si ricava dalla tabella che segue, in base alla configurazione del riduttore e al tipo di riempimento (illustrato più avanti nel capitolo sulla lubrificazione).

where C_{rt} is a coefficient that is found in the following table, based on the configuration of the reduction gear and on the filling up type (illustrated further on in the lubricating chapter).

wobei der Koeffizient C_{rt} anhand der Konfiguration vom Planetengetriebe und der Art der Füllung der Tabelle unten entnommen werden kann (siehe auch Kapitel Schmierung).



Sur la base du rapport entre la charge nominale applicable en x, égale à 36000N, et la charge appliquée, on obtient le facteur correctif $k_{r,2}$:

De la relación entre la carga nominal aplicable en x, que vale 36000N, y la carga aplicada se obtiene el factor de corrección $k_{r,2}$:

Da relação entre a carga nominal aplicável em x, equivalente a 36000N, e a carga aplicada obtém-se o fator corretivo $k_{r,2}$:

$$k_{r,2} = \frac{F_{r,2}}{F_{r,2nom}} = \frac{30000}{36000} = 0.83$$

Sur le graphique du facteur correctif, correspondant à cette valeur de $k_{r,2}$ on trouve une valeur du facteur de durée, égale à environ 200000 $n_2 \cdot h$.

En el gráfico del factor de corrección, en correspondencia con este valor de $k_{r,2}$ tenemos un valor del factor de duración, que vale aproximadamente 200000 $n_2 \cdot h$.

No gráfico do fator corretivo, em correspondência deste valor de $k_{r,2}$ encontra-se um valor do fator de duração, igual a cerca de 200000 $n_2 \cdot h$.

5.4 Contrôle de la puissance thermique

Si la puissance transmise du réducteur, c'est-à-dire la puissance exigée à l'entrée P_{r1} , est supérieure à la puissance thermique P_t , il est nécessaire de prévoir un système auxiliaire de refroidissement. La valeur de la puissance thermique des réducteurs étant calculée dans l'hypothèse de $t_a=20^\circ\text{C}$ et $n_1=1000 \text{ mn}^{-1}$, quand les conditions de fonctionnement réelles s'écartent de cette condition, il faut corriger la valeur de P_t par les facteurs K_t , facteur de température, et K_v , facteur de vitesse, qu'on peut trouver sur les tableaux suivants:

5.4 Comprobación de la potencia térmica

Si la potencia transmitida por el reductor, es decir la potencia requerida en entrada P_{r1} , es mayor que la potencia térmica P_t entonces es necesario predisponer un sistema de refrigeración auxiliar. Puesto que el valor de la potencia térmica de los reductores está calculado en el supuesto de $t_a=20^\circ\text{C}$ y $n_1=1000 \text{ min}^{-1}$, cuando las condiciones reales de funcionamiento difieren de esta condición es necesario corregir el valor de P_t utilizando los factores K_t , factor de temperatura, y K_v , factor de velocidad, que se pueden sacar de las tablas siguientes:

5.4 Verificação da potência térmica

Se a potência transmitida pelo redutor, ou seja, a potência necessária em entrada P_{r1} , é superior à potência térmica P_t é necessário preparar um sistema de arrefecimento auxiliar. Considerando que o valor da potência térmica dos redutores é calculado na hipótese de $t_a = 20^\circ\text{C}$ e $n_1 = 1000 \text{ min}^{-1}$, quando as reais condições de funcionamento se afastam desta condição é necessário corrigir o valor de P_t mediante os fatores K_t , fator de temperatura, e K_v , fator de velocidade, que se podem obter nas seguintes tabelas:

| K_t | minutes de fonctionnement/h Minutos de funcionamiento / hora minutos de funcionamento / hora | | t_a | | | | | |
|---|--|------|-------|------|------|------|------|------|
| | | | 10°C | 20°C | 30°C | 40°C | 50°C | 60°C |
| Service continu Servicio continuo Serviço contínuo | 60 | 100% | 0.9 | 1 | 1.15 | 1.4 | 1.75 | 2.35 |
| | 48 | 80% | 0.8 | 0.9 | 1.05 | 1.25 | 1.55 | 2.1 |
| Service intermittent Servicio intermitente Serviço intermitente | 36 | 60% | 0.7 | 0.8 | 0.95 | 1.1 | 1.4 | 1.85 |
| | 24 | 40% | 0.6 | 0.7 | 0.8 | 0.95 | 1.2 | 1.6 |
| | 12 | 20% | 0.5 | 0.6 | 0.7 | 0.8 | 1.05 | 1.35 |

| n_1 [min ⁻¹] | K_v |
|----------------------------|-------|
| 500 | 1.08 |
| 750 | 1.04 |
| 1000 | 1.00 |
| 1250 | 0.95 |
| 1500 | 0.89 |
| 1750 | 0.82 |
| 2000 | 0.75 |
| 2250 | 0.66 |
| 2500 | 0.59 |
| 2750 | 0.54 |
| 3000 | 0.48 |

La puissance thermique corrigée P'_t se calcule en appliquant la formule suivante:

La potencia térmica corregida P'_t se calcula con la fórmula:

A potência térmica corrigida P'_t é calculada com a seguinte fórmula:

$$P'_t = \frac{P_t \cdot K_v}{K_t}$$

Si $P_{r1} > P'_t$ il faut installer un système auxiliaire de refroidissement pour évacuer la puissance thermique en excès, qu'on peut trouver en appliquant la formule suivante:

Si resulta $P_{r1} > P'_t$ es necesario instalar un sistema auxiliar de refrigeración para eliminar la potencia térmica en exceso, que se puede obtener con la fórmula:

Se resulta $P_{r1} > P'_t$ é necessário instalar um sistema auxiliar de arrefecimento para eliminar a potência térmica em excesso, que se pode obter através da fórmula:

$$P_s = \frac{(P_{r1} - P'_t) \cdot C_{rt}}{860}$$

où C_{rt} est un coefficient qu'on trouve dans le tableau ci-dessous, en fonction de la configuration du réducteur et du type de remplissage (illustré plus loin dans le chapitre sur la lubrification).

Donde C_{rt} es un coeficiente que se saca de la tabla siguiente, según la configuración del reductor y el tipo de llenado (ilustrado más adelante en el capítulo sobre la lubricación).

na qual C_{rt} é um coeficiente que se obtém através da tabela que segue, com base na configuração do redutor e do tipo de enchimento (ilustrado mais adiante no capítulo relativo à lubrificação).

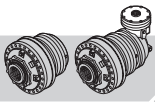

| C_{rt} | | Metà riempimento Filled half way Halb gefüllt | Pieno riempimento Filled to the top Ganz gefüllt |
|----------|----------|---|--|
| | | RR ... - | - |
| RR ... D | RA ... - | 34 | 42 |
| RR ... T | RA ... D | 50 | 63 |
| RR ... Q | RA ... T | 66 | 83 |

La portata di olio in litri al minuto, necessaria per smaltire la potenza P_s si calcola come:

The flow rate of oil in litres a minute, necessary to get rid of power P_s , is calculated as:

Der Öldurchsatz in Litern pro Minute, der zum Ableiten der Leistung P_s erforderlich ist, wird wie folgt berechnet:

$$q = \frac{(P_{r1} - P'_t) \cdot C_{rt} \cdot 0.07}{t_R - t_S}$$

dove t_R e t_S sono rispettivamente la temperatura di funzionamento del riduttore (ovvero la temperatura dell'olio all'interno del riduttore) e la temperatura dell'olio in uscita dallo scambiatore.

where t_R and t_S are, respectively, the reduction gear operating temperature (that is, the temperature of the oil inside the reduction gear) and the temperature of the oil leaving the exchanger.

wobei t_R und t_S die Betriebstemperatur vom Planetengetriebe (d.h. die Öltemperatur im Planetengetriebe) bzw. die Öltemperatur am Ausgang vom Wärmeaustauscher sind.

Esempio

Un riduttore RR1010T funziona alle seguenti condizioni:

- velocità in ingresso $n_1=1500 \text{ min}^{-1}$;
- potenza richiesta in ingresso $P_{r1} = 30 \text{ kW}$;
- metà riempimento;
- temperatura ambiente $t_a=30^\circ\text{C}$;
- 24 minuti di funzionamento ogni ora.

Example

An RR1010T reduction gear works at the following conditions:

- input speed $n_1=1500 \text{ min}^{-1}$;
- power required in input $P_{r1} = 30 \text{ kW}$;
- filled halfway;
- ambient temperature $t_a=30^\circ\text{C}$;
- 24 minutes working every hour.

Beispiel

Ein Planetengetriebe RR1010T funktioniert unter folgenden Bedingungen:

- Geschwindigkeit am Eingang $n_1=1500 \text{ min}^{-1}$;
- verlangte Leistung am Eingang $P_{r1} = 30 \text{ kW}$;
- halbe Füllung;
- Umgebungstemperatur $t_a=30^\circ\text{C}$;
- 24 Minuten Betrieb pro Stunde.

Dalla tabella dei dati tecnici dei riduttori RR1010 si ricava il valore di potenza termica $P_t=17 \text{ kW}$ del riduttore in oggetto, che deve essere corretto introducendo i fattori K_t e K_v ottenuti dalle rispettive tabelle:

The thermal power value $P_t=17 \text{ kW}$ of the subject reduction gear is found in the RR1010 reduction gears table and has to be corrected by introducing factors K_t and K_v taken from the relative tables:

Aus der Tabelle mit den technischen Daten der Planetengetriebe RR1010 kann der Wert für die Wärmeleistung $P_t=17 \text{ kW}$ vom Planetengetriebe entnommen werden. Dieser Wert muss mit den Faktoren K_t und K_v korrigiert werden, die den jeweiligen Tabellen entnommen werden können:

$$P'_t = \frac{P_t \cdot K_v}{K_t} = \frac{17 \cdot 0.89}{0.80} = 18.9 \text{ kW}$$

Poiché la potenza richiesta è maggiore della potenza termica che il riduttore è in grado di smaltire, occorre installare un sistema ausiliario di raffreddamento per smaltire una potenza pari a:

Since the power required is greater than the thermal power the reduction gear is able to get rid of, an auxiliary cooling system needs to be installed to get rid of a power equivalent to:

Da die verlangte Leistung größer ist als die Wärmeleistung, die das Planetengetriebe ableiten kann, muss ein zusätzliches Kühlsystem zur Wärmeableitung mit folgender Leistung installiert werden:

$$P_s = \frac{(P_{r1} - P'_t) \cdot C_{rt}}{860} = \frac{(30 - 18.9) \cdot 50}{860} = 0.64 \text{ kW}$$

dove il valore di C_{rt} è stato ricavato dall'apposita tabella per il riduttore L3.

where the C_{rt} value was taken from the relative table for the L3 reduction gear.

wobei der Wert C_{rt} der entsprechenden Tabelle für das Planetengetriebe L3 entnommen werden kann.

Utilizzando un sistema di raffreddamento a ricircolo d'olio, supponendo che la temperatura dell'olio entrante nello scambiatore è $t_R=90^\circ\text{C}$ mentre quella uscente è $t_S=65^\circ\text{C}$, la portata necessaria a smaltire tale potenza è pari a:

Utilising an oil recirculating cooling system, assuming that the temperature of the oil entering the exchanger is $t_R=90^\circ\text{C}$ while when it leaves the exchanger it is $t_S=65^\circ\text{C}$, the rate necessary to get rid of such a power is equivalent to:

Bei Einsatz eines Kühlsystems mit Ölrücklauf und unter der Annahme, dass die Temperatur vom Öl am Eingang vom Wärmeaustauscher $t_R=90^\circ\text{C}$ und am Ausgang $t_S=65^\circ\text{C}$ beträgt, ist folgender Durchsatz zur Ableitung der Wärmeleistung erforderlich:

$$q = \frac{(P_{r1} - P'_t) \cdot C_{rt} \cdot 0.07}{t_R - t_S} = \frac{(30 - 18.9) \cdot 50 \cdot 0.07}{90 - 65} = 1.6 \text{ l/min}$$

Consultare il capitolo relativo alla lubrificazione per la scelta del sistema ausiliario di raffreddamento più idoneo tra quelli proposti.

Consult the lubrication chapter to choose the most suitable auxiliary cooling system out of those proposed.

Nähere Informationen zur Auswahl vom geeigneten zusätzlichen Kühlsystem können dem Kapitel "Schmierung" entnommen werden.

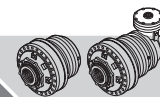

| C_{rt} | | Metà riempimento Filled half way Halb gefüllt | Pieno riempimento Filled to the top Ganz gefüllt |
|----------|----------|---|--|
| | | RR ... - | - |
| RR ... D | RA ... - | 34 | 42 |
| RR ... T | RA ... D | 50 | 63 |
| RR ... Q | RA ... T | 66 | 83 |

Le débit d'huile en litres/minute, nécessaire pour évacuer la puissance P_s se calcule de la manière suivante:

El caudal de aceite en litros por minuto, necesario para eliminar la potencia P_s se calcula como:

A capacidade de óleo em litros por minuto, necessária para eliminar a potência P_s calcula-se como:

$$q = \frac{(P_{r1} - P'_t) \cdot C_{rt} \cdot 0.07}{t_R - t_S}$$

où t_R et t_S sont respectivement la température de fonctionnement du réducteur (c'est-à-dire la température de l'huile à l'intérieur du réducteur) et la température de l'huile à la sortie de l'échangeur.

Donde t_R y t_S son, respectivamente, la temperatura de funcionamiento del reductor (es decir la temperatura del aceite dentro del reductor) y la temperatura del aceite en salida del intercambiador.

onde t_R e t_S são, respetivamente, a temperatura de funcionamento do redutor (ou seja, a temperatura do óleo no interior do redutor) e a temperatura do óleo à saída do permutador.

Exemple

Un réducteur RR1010T fonctionne aux conditions suivantes:

- vitesse à l'entrée $n_1=1500 \text{ min}^{-1}$;
- puissance exigée à l'entrée $P_{r1} = 30 \text{ kW}$;
- remplissage à moitié ;
- température ambiante $t_a=30^\circ\text{C}$;
- 24 minutes de fonctionnement/h.

A partir du tableau des caractéristiques techniques des réducteurs RR1010, on trouve la valeur de puissance thermique $P_t=17 \text{ kW}$ du réducteur en objet, qui doit être corrigée en introduisant les facteurs K_t et K_v obtenus à partir des tableaux respectifs:

Ejemplo

Un reductor RR1010T funciona en las siguientes condiciones:

- velocidad en entrada $n_1=1500 \text{ min}^{-1}$;
- potencia requerida en entrada $P_{r1} = 30 \text{ kW}$;
- mitad llenado;
- temperatura ambiente $t_a=30^\circ\text{C}$;
- 24 minutos de funcionamiento cada hora.

En la tabla de los datos técnicos de los reductores RR1010 sacamos el valor de potencia térmica $P_t=17 \text{ kW}$ del reductor considerado, que se debe corregir introduciendo los factores K_t y K_v obtenidos de las respectivas tablas:

Exemplo

Um redutor RR1010T funciona às seguintes condições:

- velocidade em entrada $n_1=1500 \text{ min}^{-1}$;
- potência necessária em entrada $P_{r1} = 30 \text{ kW}$;
- meio enchimento;
- temperatura ambiente $t_a=30^\circ\text{C}$;
- 24 minutos de funcionamento cada hora.

Através da tabela dos dados técnicos dos redutores RR1010 obtém-se o valor de potência térmica $P_t=17 \text{ kW}$ do redutor em objeto, que deve ser corrigido introduzindo os fatores K_t e K_v obtidos pelas respetivas tabelas:

$$P'_t = \frac{P_t \cdot K_v}{K_t} = \frac{17 \cdot 0.89}{0.80} = 18.9 \text{ kW}$$

La puissance exigée étant supérieure à la puissance thermique que le réducteur est en mesure d'évacuer, il faut installer un système auxiliaire de refroidissement pour évacuer une puissance égale à:

Puesto que la potencia requerida es mayor que la potencia térmica que el reductor logra eliminar, es necesario instalar un sistema auxiliar de refrigeración para eliminar una potencia igual que:

Dado que a potência necessária é maior do que a potência térmica que o redutor é capaz de eliminar, é necessário instalar um sistema auxiliar de arrefecimento para eliminar uma potência equivalente a:

$$P_s = \frac{(P_{r1} - P'_t) \cdot C_{rt}}{860} = \frac{(30 - 18.9) \cdot 50}{860} = 0.64 \text{ kW}$$

où la valeur de C_{rt} a été trouvée par l'intermédiaire du tableau pour le réducteur L3.

Donde el valor de C_{rt} se ha sacado de la correspondiente tabla para el reductor L3.

onde o valor de C_{rt} foi obtido na respetiva tabela para o redutor L3.

En utilisant un système de refroidissement à recirculation d'huile, en supposant que la température de l'huile entrant dans l'échangeur est $t_R=90^\circ\text{C}$ alors que la température de l'huile sortant est $t_S=65^\circ\text{C}$, le débit nécessaire à évacuer cette puissance est égal à:

Utilizando un sistema de refrigeración por recirculación de aceite, suponiendo que la temperatura del aceite entrante en el intercambiador es $t_R=90^\circ\text{C}$ mientras que la de salida es $t_S=65^\circ\text{C}$, el caudal necesario para eliminar dicha potencia es de:

Utilizando um sistema de arrefecimento de recirculação de óleo, supondo que a temperatura do óleo que entra no permutador é $t_R = 90^\circ\text{C}$ enquanto que aquele que sai é $t_S = 65^\circ\text{C}$, o caudal necessário para eliminar tal potência é equivalente a:

$$q = \frac{(P_{r1} - P'_t) \cdot C_{rt} \cdot 0.07}{t_R - t_S} = \frac{(30 - 18.9) \cdot 50 \cdot 0.07}{90 - 65} = 1.6 \text{ l/min}$$

Voir le chapitre relatif à la lubrification pour choisir le système auxiliaire de refroidissement le plus adapté parmi ceux qui sont proposés.

Consúltese el capítulo correspondiente a la lubricación para la selección del sistema auxiliar de refrigeración más idóneo entre los propuestos.

Consultar o capítulo relativo à lubrificação para a escolha do sistema auxiliar de arrefecimento mais idóneo entre aqueles propostos.

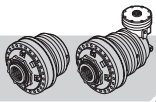

6 LUBRIFICAZIONE

Salvo diverse indicazioni, tutti i riduttori sono forniti privi di olio lubrificante; è compito dell'utilizzatore effettuare il riempimento prima della messa in servizio.

I riduttori con uscita tipo SI (dove presente l'ingrassatore), VI e ZI vengono forniti privi di grasso; si raccomanda l'utilizzo di grasso per cuscinetti al sapone di Lito (olio base minerale).

L'olio lubrificante all'interno di un riduttore epicicloidale ha il compito di:

- ridurre l'attrito tra gli organi di trasmissione, aumentandone il rendimento;
- contribuire allo smaltimento del calore, trasferendolo dagli organi in movimento alla carcassa;
- proteggere le superfici dalla formazione di ruggine;
- ridurre la rumorosità.



Una corretta lubrificazione assicura un buon funzionamento ed una lunga durata del riduttore.

6 LUBRICATION

Unless specified otherwise, all reduction gears are supplied without lubricant oil; the user has to fill up prior to commissioning.

Reduction gears with an SI (with the greaser), VI and ZI type output, are supplied without grease; we recommend using lithium soap grease for bearings (mineral based oil).

The lubricant oil inside a planetary reduction gear has the job of:

- *reducing friction between the transmission parts, increasing their efficiency;*
- *helping to get rid of heat, transferring it from the moving parts to the casing;*
- *protecting surfaces from going rusty;*
- *reducing noise.*

Correct lubrication ensures good operation and a long life of the reduction gear.

6 SCHMIERUNG

Vorbehaltlich anders lautender Angaben werden alle Planetengetriebe ohne Schmieröl geliefert. Der Benutzer ist deshalb dafür zuständig, das Öl vor der Inbetriebnahme einzufüllen. Die Untersetzungen mit Ausgang des Typs SI (wo eine Schmierungsvorrichtung vorhanden ist) sowie die Modelle VI und ZI werden ohne Fett ausgeliefert; es wird empfohlen, Fett mit Lithiumseife für Lager (Öl auf Mineralbasis) zu verwenden. Das Schmieröl im Planetengetriebe hat die Aufgabe:

- die Reibung zwischen den Antriebsorganen zu reduzieren und damit den Wirkungsgrad zu verbessern;
- zur Wärmeableitung beizutragen, und war durch Übertragung der Wärme von den laufenden Getriebeteilen auf das Gehäuse;
- die Oberflächen vor Rostbildung zu schützen;
- den Lärmpegel zu reduzieren.

Eine korrekte Schmierung garantiert für einen störungsfreien Betrieb und eine lange Lebensdauer des Planetengetriebes.

6.1 Viscosità

La viscosità cinematica del lubrificante deve essere scelta in funzione della temperatura di esercizio e della velocità di rotazione.

Poiché la viscosità diminuisce al crescere della temperatura, per temperature di funzionamento elevate è opportuno scegliere un olio con classe di viscosità maggiore.

Nel caso di riduzioni molto lente (velocità in uscita n_2 inferiore a 5 min^{-1}) si consiglia di utilizzare un olio con classe di viscosità elevata; viceversa, nel caso di riduttore con elevata velocità di rotazione si consiglia di impiegare un olio con classe di viscosità bassa.

6.2 Additivi

L'uso di additivi di tipo EP (Extreme Pressure) serve a diminuire l'usura superficiale di ingranaggi e cuscinetti. Questi additivi, infatti, sotto l'effetto del calore e della pressione tra le superfici sottoposte a carico, reagiscono chimicamente con le superfici stesse, formando un rivestimento protettivo che impedisce la formazione di micro-saldature ed il conseguente grippaggio.

6.1 Viscosity

The lubricant's kinematic viscosity must be chosen in accordance with both the operating temperature and rotation speed.

Since viscosity diminishes as the temperature rises, for high operating temperatures it is advisable to choose a higher viscosity class oil.

In the case of very slow reductions (input speed below 5 min^{-1}) we recommend using a high viscosity class oil or, vice versa, in the case of reduction gears with a high rotation speed, we recommend using a low viscosity class oil.

6.2 Additives

The use of EP type additives (Extreme Pressure) helps reduce surface wear of the gears and bearings. As a matter of fact, these additives, under the effect of the heat and pressure between surfaces subject to load, react chemically with these same surfaces, forming a protective coating that prevents the formation of micro-weldings and consequent seizure.

6.1 Viskosität

Die kinematische Viskosität vom Schmiermittel muss in Abhängigkeit von der Betriebstemperatur und der Rotationsgeschwindigkeit gewählt werden.

Da die Viskosität mit steigender Temperatur abnimmt, müssen für Anwendungen mit hohen Betriebstemperaturen Öle einer größeren Viskositätsklasse gewählt werden.

Bei sehr langsamen Planetengetrieben (Geschwindigkeit am Ausgang n_2 unter 5 min^{-1}) wird zur Verwendung von Ölen mit einer hohen Viskosität geraten. Umgekehrt gilt, dass für Planetengetriebe mit hoher Rotationsgeschwindigkeit Öle mit einer niedrigen Viskosität verwendet werden sollten.

6.2 Additive

Durch die Verwendung von Additiven vom Typ EP (Extreme Pressure) wird der Oberflächenverschleiß von Zahnrädern und Lagern reduziert. Diese Additive unter Einwirkung der Wärme und dem Druck zwischen den belasteten Oberflächen eine chemische Reaktion mit den Oberflächen aus, die zur Bildung einer Schutzschicht führt, welche die Ausbildung von Mikroschweißungen und das daraus folgende Festfressen verhindert.



6 LUBRIFICATION

A moins d'indications différentes, tous les réducteurs sont livrés sans huile de lubrification; c'est à l'utilisateur d'effectuer le nourrissage avant la mise en service du réducteur. Les réducteurs, avec sortie type SI (s'il y a graisseur) VI et ZI sont livrés sans graisse. L'utilisation de graisses pour roulements au savon de lithium (huile base minérale) est recommandée. Le rôle de l'huile de lubrification à l'intérieur d'un réducteur épicycloïdal est de:

- réduire le frottement entre les organes de transmission, ce qui contribue à augmenter leur rendement;
- contribuer à l'évacuation de la chaleur, en la faisant passer des organes en mouvement au bâti;
- protéger les surfaces de la formation de rouille;
- réduire les nuisances sonores.



Une lubrification correcte assure un bon fonctionnement et une durabilité majeure du réducteur.

6.1 Viscosité

La viscosité cinématique du lubrifiant doit être choisie en fonction de la température de fonctionnement et de la vitesse de rotation.

La viscosité diminue au fur et à mesure que la température monte, pour des températures de fonctionnement élevées, il est recommandé de choisir une huile ayant une classe de viscosité supérieure. En cas de réductions très lentes (vitesse à la sortie n_2 inférieure à 5 mn^{-1}) il est conseillé d'utiliser une huile ayant une classe de viscosité élevée; vice-versa, dans le cas de réducteur dont la vitesse de rotation est rapide, il est conseillé de choisir une huile ayant une classe de viscosité basse.

6.2 Additifs

L'emploi d'additifs de type EP (Extreme Pressure) permet de diminuer l'usure des surfaces des engrenages et des roulements. En effet, sous l'effet de la chaleur et de la pression entre les surfaces soumises à la charge, ces additifs réagissent chimiquement avec les surfaces en question, en formant un revêtement protecteur qui empêche la formation de micro-soudures et par conséquent le grippage.

6 LUBRICACIÓN

Salvo indicaciones contrarias, todos los reductores son suministrados sin aceite lubricante; es tarea del usuario efectuar el llenado antes de ponerlos en servicio. Los reductores con salida de tipo SI (donde está presente el engrasador), VI y ZI son suministrados sin grasa; se recomienda utilizar grasa para cojinetes al jabón de Litio (aceite base mineral). El aceite lubricante dentro de un reductor epicicloidal tiene la tarea de:

- *reducir la fricción entre los órganos de transmisión, aumentando su rendimiento;*
- *contribuir en la eliminación del calor, transfiriéndolo desde los órganos en movimiento a la carcasa;*
- *proteger las superficies contra la formación de óxido;*
- *reducir el ruido.*

Una lubricación correcta asegura un buen funcionamiento y una larga duración del reductor.

6.1 Viscosidad

Se debe seleccionar la viscosidad cinemática del lubricante en función de la temperatura de funcionamiento y de la velocidad de rotación.

Puesto la viscosidad disminuye al aumentar la temperatura, para altas temperaturas de funcionamiento es oportuno elegir un aceite con clase de viscosidad mayor. En el caso de reducciones muy lentas (velocidad en salida n_2 por debajo de 5 min^{-1}) se aconseja utilizar un aceite con alta clase de viscosidad; viceversa, en caso de reductor con alta velocidad de rotación se aconseja utilizar un aceite con baja clase de viscosidad.

6.2 Aditivos

El uso de aditivos de tipo EP (Extreme Pressure) sirve para reducir el desgaste superficial de engranajes y cojinetes. Estos aditivos, efectivamente, bajo el efecto del calor y de la presión entre las superficies sometidas a carga, reaccionan químicamente con las propias superficies, formando un revestimiento protector que impide la formación de micro-soldaduras con consiguiente agarrotamiento.

6 LUBRIFICAÇÃO

Salvo diversas indicações, todos os reductores são fornecidos sem óleo lubrificante e portanto o usuário deve efetuar o enchimento antes da entrada em funcionamento. Os reductores com saída nas versões: SI (em que está presente o lubrificador) VI e ZI são fornecidos sem graxa; recomenda-se usar graxa para rolamentos à base de sabão de lítio (óleo base mineral). O óleo lubrificante no interior de um reductor epicicloidal tem a função de:

- reduzir o atrito entre os órgãos de transmissão, aumentando o seu rendimento;
- contribuir para a eliminação do calor, transferindo-o dos órgãos em movimento para a carcaça;
- proteger as superfícies contra a formação de ferrugem;
- reduzir o nível de barulho.

Uma correta lubrificação garante o bom funcionamento e a longevidade do reductor.

6.1 Viscosidade

A viscosidade cinemática do lubrificante deve ser escolhida em função da temperatura de exercício e da velocidade de rotação.

Dado que a viscosidade diminui ao aumentar da temperatura, no caso de temperaturas elevadas de funcionamento é oportuno escolher um óleo com classe de viscosidade superior.

No caso de reduções muito lentas (velocidade em saída n_2 inferior a 5 min^{-1}) aconselhamos usar um óleo com classe de viscosidade elevada; vice-versa, no caso de reductor com elevada velocidade de rotação aconselhamos usar um óleo com classe de viscosidade baixa.

6.2 Aditivos

O uso de aditivos de tipo EP (Extreme Pressure) serve para diminuir o desgaste superficial de engrenagens e rolamentos. De fato, estes aditivos, sob o efeito do calor e da pressão entre as superfícies submetidas a carga, reagem quimicamente com as próprias superfícies, formando um revestimento de proteção que impede a formação de micro-soldaduras e a consequente gripagem.

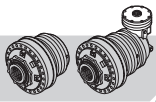

6.3 Contaminazione

Durante le prime ore di funzionamento dei riduttori, a causa del contatto tra le superfici non rodiate, si verifica una diffusione di particelle metalliche nell'olio. La presenza di queste particelle ha un effetto certamente negativo sulla durata di vita di ingranaggi e cuscinetti.

Per ridurre la presenza di particelle metalliche nell'olio si consiglia di:

- effettuare la sostituzione dell'olio dei riduttori e dei freni dopo le prime 100 ore di funzionamento e successivamente ogni 1500- 2000h od ogni 12 mesi;
- pulire periodicamente i tappi magnetici;
- eseguire il filtraggio dell'olio, mediante un sistema ausiliario di raffreddamento.

I tipi di lubrificante consigliati sono indicati nelle tabelle seguenti:

6.3 Contamination

During the first hours of operation of the reduction gears, due to the contact between surfaces that have not been run-in, you will find metallic particles in the oil. Undoubtedly these particles have a negative effect on the life of gears and bearings.

To reduce the number of metallic particles in the oil we recommend:

- *changing the oil of the gearboxes and brakes after the first 100 hours of working and then every 1500-2000 hours or every 12 months.;*
- *cleaning the magnetic plugs regularly;*
- *filtering the oil by means of an auxiliary cooling system.*

The recommended lubricants are listed in the following table:

6.3 Verunreinigungen

Während der ersten Betriebsstunden der Planetengetriebe gelangen durch den Kontakt der nicht eingelaufenen Oberflächen Metallpartikel ins Öl. Das Vorhandensein dieser Metallpartikel wird sich deutlich zum Nachteil der Lebensdauer von Zahnrädern und Lagern aus.

Zur Reduzierung der Metallpartikel im Öl wie folgt vorgehen:

- Nach den ersten 100 Betriebsstunden einen Ölwechsel durchführen der planetengetriebe und die Bremsen, dann alle 1500-2000 Betriebsstunden, mindestens aber alle 12 Monate;
- Die Magnetdeckel regelmäßig sauber machen;
- Das Öl mit einem zusätzlichen Kühlsystem filtern.

Die empfohlenen Schmiermittel können der Tabelle unten entnommen werden:

Lubrificanti per uso generale

General purpose lubricants

Schmiermittel für allgemeinen Gebrauch

| Temperatura ambiente Ambient temperature Umgebungstemperatur | Oli Minerali Mineral oils Mineralöle | | | Oli Sintetici Polialfaolefine (PAO) Poly-Alpha-Olefin synthetic oils (PAO) Synthetische Poly-Alpha-Olefin-Öle (PAO) | | | Oli Sintetici Poliglicoli (PG) Polyglycol synthetic oils (PG) Synthetische Polyglykolöle (PG) | | |
|--|--|---------------------|---------------------|---|--------------------------|--------------------------|---|----------------------|----------------------|
| | -10°C/+30°C | +10°C/+45°C | +30°C/+60°C | -20°C/+60°C | | | -20°C/+60°C | | |
| Produttore Manufacturer Hersteller | ISO VG 150 | ISO VG 220 | ISO VG 320 | ISO VG 150 | ISO VG 220 | ISO VG 320 | ISO VG 150 | ISO VG 220 | ISO VG 320 |
| AGIP | Blasia 150 | Blasia 220 | Blasia 320 | - | Blasia SX 220 | Blasia SX 320 | Blasia S 150 | Blasia S 220 | Blasia S 320 |
| BP | Energol GR-XP 150 | Energol GR-XP 220 | Energol GR-XP 320 | Enersyn EPX 150 | Enersyn EPX 220 | Enersyn EPX 320 | Enersyn SG 150 | Enersyn SG-XP 220 | Enersyn SG-XP 320 |
| CASTROL | Alpha SP 150 | Alpha SP 220 | Alpha SP 320 | Alphasyn EP 150 | Alphasyn EP 220 | Alphasyn EP 320 | Alphasyn PG 150 | Alphasyn PG 220 | Alphasyn PG 320 |
| CHEVRON | Ultra Gear 150 | Ultra Gear 220 | Ultra Gear 320 | Tegra Synthetic Gear 150 | Tegra Synthetic Gear 220 | Tegra Synthetic Gear 320 | HiPerSYN 150 | HiPerSYN 220 | HiPerSYN 320 |
| KLÜBER | Klüberoil GEM 1-150 | Klüberoil GEM 1-220 | Klüberoil GEM 1-320 | Klübersynth EG 4-150 | Klübersynth EG 4-220 | Klübersynth EG 4-320 | Klübersynth GH 6-150 | Klübersynth GH 6-220 | Klübersynth GH 6-320 |
| MOBIL | Mobilgear XMP 150 | Mobilgear XMP 220 | Mobilgear XMP 320 | Mobilgear SHC Gear 150 | Mobilgear SHC Gear 220 | Mobilgear SHC Gear 320 | Glygoyle 150 | Glygoyle 220 | Glygoyle 320 |
| MOLIKOTE | L-0115 | L-0122 | L-0132 | L-1115 | L-1122 | L-1132 | - | - | - |
| SHELL | Omala S2 G 150 | Omala S2 G 220 | Omala S2 G 320 | Omala S4 GX 150 | Omala S4 GX 220 | Omala S4 GX 320 | Omala S4 WE 150 | Omala S4 WE 220 | Omala S4 WE 320 |
| TEXACO | Meropa 150 | Meropa 220 | Meropa 320 | Pinnacle EP 150 | Pinnacle EP 220 | Pinnacle EP 320 | - | Synlube CLP 220 | Synlube CLP 320 |
| TOTAL | Carter EP 150 | Carter EP 220 | Carter EP 320 | Carter SH 150 | Carter SH 220 | Carter SH 320 | Carter SY 150 | Carter SY 220 | Carter SY 320 |
| TRIBOL | 1100/150 | 1100/220 | 1100/320 | 1510/150 | 1510/220 | 1510/320 | 800/150 | 800/220 | 800/320 |

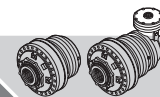

6.3 Encrassement

Durant les premières heures de fonctionnement des réducteurs, à cause du contact entre les surfaces non rodées, des particules métalliques salissent l'huile. La présence de ces particules a un effet négatif sur la durée de vie des engrenages et des roulements.

Pour réduire la présence de particules métalliques dans l'huile, il est conseillé de:

- changer l'huile de les réducteurs et de les freins après les 100 premières heures de fonctionnement et par la suite, toutes les 1500-2000 heures ou tous les 12 mois;
- nettoyer périodiquement les bouchons magnétiques;
- filtrer l'huile, à l'aide d'un système auxiliaire de refroidissement.

Les types de lubrifiant conseillés sont indiqués sur le tableau suivant:

6.3 Contaminación

Durante las primeras horas de funcionamiento de los reductores, debido al contacto entre las superficies no rodadas, se produce una difusión de partículas metálicas en el aceite. La presencia de estas partículas tiene un efecto ciertamente negativo sobre la duración de vida de engranajes y cojinetes.

Para reducir la presencia de partículas metálicas en el aceite se aconseja:

- *sustituir el aceite de los reductores y de los frenos al cabo de las primeras 100 horas de funcionamiento y sucesivamente cada 1500-2000 horas o cada 12 meses;*
- *limpiar periódicamente los tapones magnéticos;*
- *filtrar el aceite, mediante un sistema auxiliar de refrigeración.*

Los tipos de lubricante aconsejados se indican en la tabla siguiente:

6.3 Contaminação

Durante as primeiras horas de funcionamento dos redutores, devido ao contato entre as superfícies não rodadas, verifica-se uma difusão de partículas metálicas no óleo. A presença destas partículas tem um efeito certamente negativo na duração de vida das engrenagens e dos rolamentos.

Para reduzir a presença de partículas metálicas no óleo aconselhamos:

- proceder à substituição do óleo dos redutores e os freios depois das primeiras 100 horas de funcionamento e em seguida cada 1500-2000 horas ou cada 12 meses;
- limpar periodicamente os tampões magnéticos;
- efetuar a filtragem do óleo, através de um sistema auxiliar de arrefecimento.

Os tipos de lubrificante aconselhados estão indicados na tabela seguinte:

Lubrifiants pour toute utilisation

Lubricantes para uso general

Lubrificantes para uso geral

| | Huiles Minérales Aceites Minerales Óleos Minerais | | | Huiles Synthétiques Polyalphaoléfine (PAO) Aceites Sintéticos Polialfaolefinas (PAO) Óleos Sintéticos Polialfaolefine (PAO) | | | Huiles Synthétiques Polyglycoles (PG) Aceites Sintéticos Poliglicol (PG) Óleos Sintéticos Poliglicóis (PG) | | |
|--|---|---------------------|---------------------|---|--------------------------|--------------------------|--|----------------------|----------------------|
| | -10°C/+30°C | +10°C/+45°C | +30°C/+60°C | -20°C/+60°C | | | -20°C/+60°C | | |
| Température ambiante Temperatura ambiente Temperatura ambiente | ISO VG | ISO VG | ISO VG | ISO VG | ISO VG | ISO VG | ISO VG | ISO VG | ISO VG |
| Producteur Productor Produtor | 150 | 220 | 320 | 150 | 220 | 320 | 150 | 220 | 320 |
| AGIP | Blasia 150 | Blasia 220 | Blasia 320 | - | Blasia SX 220 | Blasia SX 320 | Blasia S 150 | Blasia S 220 | Blasia S 320 |
| BP | Energol GR-XP 150 | Energol GR-XP 220 | Energol GR-XP 320 | Enersyn EPX 150 | Enersyn EPX 220 | Enersyn EPX 320 | Enersyn SG 150 | Enersyn SG-XP 220 | Enersyn SG-XP 320 |
| CASTROL | Alpha SP 150 | Alpha SP 220 | Alpha SP 320 | Alphasyn EP 150 | Alphasyn EP 220 | Alphasyn EP 320 | Alphasyn PG 150 | Alphasyn PG 220 | Alphasyn PG 320 |
| CHEVRON | Ultra Gear 150 | Ultra Gear 220 | Ultra Gear 320 | Tegra Synthetic Gear 150 | Tegra Synthetic Gear 220 | Tegra Synthetic Gear 320 | HiPerSYN 150 | HiPerSYN 220 | HiPerSYN 320 |
| KLÜBER | Klüberoil GEM 1-150 | Klüberoil GEM 1-220 | Klüberoil GEM 1-320 | Klübersynth EG 4-150 | Klübersynth EG 4-220 | Klübersynth EG 4-320 | Klübersynth GH 6-150 | Klübersynth GH 6-220 | Klübersynth GH 6-320 |
| MOBIL | Mobilgear XMP 150 | Mobilgear XMP 220 | Mobilgear XMP 320 | Mobilgear SHC Gear 150 | Mobilgear SHC Gear 220 | Mobilgear SHC Gear 320 | Glygoyle 150 | Glygoyle 220 | Glygoyle 320 |
| MOLIKOTE | L-0115 | L-0122 | L-0132 | L-1115 | L-1122 | L-1132 | - | - | - |
| SHELL | Omala S2 G 150 | Omala S2 G 220 | Omala S2 G 320 | Omala S4 GX 150 | Omala S4 GX 220 | Omala S4 GX 320 | Omala S4 WE 150 | Omala S4 WE 220 | Omala S4 WE 320 |
| TEXACO | Meropa 150 | Meropa 220 | Meropa 320 | Pinnacle EP 150 | Pinnacle EP 220 | Pinnacle EP 320 | - | Synlube CLP 220 | Synlube CLP 320 |
| TOTAL | Carter EP 150 | Carter EP 220 | Carter EP 320 | Carter SH 150 | Carter SH 220 | Carter SH 320 | Carter SY 150 | Carter SY 220 | Carter SY 320 |
| TRIBOL | 1100/150 | 1100/220 | 1100/320 | 1510/150 | 1510/220 | 1510/320 | 800/150 | 800/220 | 800/320 |

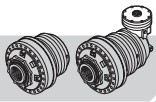

| Produttore Manufacturer Hersteller | Oli Idrraulici Hydraulic oils Hydrauliköle | | | Oli per ingranaggi Gear oils Getriebeöle | | |
|--|--|----------------------------|----------------------------|--|--------------------------|---------------------------------|
| | ISO VG 32 | ISO VG 46 | ISO VG 68 | ISO VG 150 | ISO VG 220 | ISO VG 320 |
| AGIP | Rocol Foodlube Hi Power 32 | - | - | Rocol Foodlube Hi-Torque 150 | - | Rocol Foodlube Hi-Torque 320 |
| BP | Enerpar M 32 | Enerpar M 46 | Enerpar M 68 | - | - | - |
| KLÜBER | Summit Hysyn FG 32 | Summit Hysyn FG 46 | Summit Hysyn FG 68 | Klüberoil 4 UH1 N 150 | Klüberoil 4 UH1 N 220 | Klüberoil 4 UH1 N 320 |
| MOBIL | DTE FM 32 | DTE FM 46 | DTE FM 68 | DTE FM 150 | DTE FM 220 | DTE FM 320 |
| SHELL | Cassida Fluid HF 32 | Cassida Fluid HF 46 | Cassida Fluid HF 68 | Cassida Fluid GL 150 | Cassida Fluid GL 220 | Cassida Fluid GL 320 |
| TEXACO | Cygnus Hydraulic Oil 32 | Cygnus Hydraulic Oil 46 | Cygnus Hydraulic Oil 68 | Cygnus Gear PAO 150 | Cygnus Gear PAO 220 | - |
| TOTAL | Nevastane AW 32 | Nevastane AW 46 | Nevastane AW 68 | Nevastane SL 150 | Nevastane SL 220 | Nevastane SL 320 |
| TRIBOL | Food Proof 1840/32 | Food Proof 1840/ 46 | Food Proof 1840/68 | - | Food Proof 1810/220 | Food Proof 1810/320 |

Nel caso di impiego di altri lubrificanti sintetici, verificarne la compatibilità con le tenute paraolio in NBR presenti nel riduttore.

If other synthetic lubricants are used always check their compatibility with the NBR oil seals used in the reduction gear.

Bei Verwendung synthetischer Schmiermittel muss die Kompatibilität mit den im Planetengetriebe montierten Öldichtungen aus NBR geprüft werden.



Non mescolare lubrificanti sintetici di tipo differente.

Do not mix different kinds of synthetic lubricant together.

Unterschiedliche Typen von synthetischen Schmiermitteln dürfen nicht gemischt werden.

Se le condizioni di esercizio del riduttore prevedono prolungati periodi di funzionamento tali da produrre una elevata temperatura dell'olio (>60°C) si consiglia l'utilizzo di olio sintetico, per garantire una minore usura dei componenti ed aumentare gli intervalli di sostituzione.

If the operating conditions of the reduction gear entail prolonged periods of operation such to cause the oil temperature to rise considerably (>60°C) we suggest using a synthetic oil to guarantee less wear of the components and to prolong the intervals between replacing them.

Wenn die Betriebsbedingungen vom Planetengetriebe längere Betriebszeiten vorsehen, die zu hohen Öltemperaturen führen (>60°C), wird zur Verwendung von synthetischem Öl geraten, das für einen geringeren Verschleiß der Teile und größere Abstände zwischen den Ölwechseln garantiert.

La temperatura massima del lubrificante all'interno del riduttore non deve oltrepassare i 90°C.

Maximum temperature of the lubricant inside the reduction gear must not go above 90°C.

Die Temperatur vom Schmiermittel im Planetengetriebe darf 90°C nicht übersteigen.

6.4 Posizioni di montaggio e disposizione dei tappi

Nelle figure seguenti sono mostrate le possibili posizioni di montaggio, la cui sigla deve essere specificata in fase di ordine del riduttore. Inoltre sono indicati la disposizione e la tipologia dei tappi ed il livello minimo di lubrificante, come da legenda.

6.4 Mounting positions and plugs position

You can see the possible mounting positions in the figures below. The relative initial must be specified when ordering the reduction gear. The layout and type of plugs as well as the minimum lubricant level are also indicated, as per the legend.

6.4 Montageposition und Anordnung der Deckel

Die Abbildungen unten zeigen die möglichen Montagepositionen, deren Kürzel bei der Bestellung vom Planetengetriebe angegeben werden muss. Außerdem sind die Anordnung und der Typ der Deckel sowie der Mindestölstand angegeben (siehe Legende).

Attenzione:

Per servizi continuativi (24 h) consigliamo di utilizzare tappi di sfiato con il labirinto e filtro sinterizzato assieme ad una colonnetta.

Attention!

For continuous duty (24h) uses venting plug with labyrinth and filter and a column.

Achtung!

Bei Dauerbetrieb ist es besser auf Säule gebauten Belüftungspfropfen mit synthetischem Filter und Labyrinth einzusetzen.

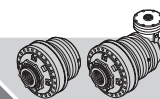

| Producteur Productor Produtor | Huiles hydrauliques Aceites hidráulicos Óleos hidráulicos | | | Huiles pour engrenages Aceites para engranajes Óleos para engranagens | | |
|-------------------------------------|---|----------------------------|----------------------------|---|--------------------------|---------------------------------|
| | ISO VG 32 | ISO VG 46 | ISO VG 68 | ISO VG 150 | ISO VG 220 | ISO VG 320 |
| AGIP | Rocol Foodlube Hi Power 32 | - | - | Rocol Foodlube Hi-Torque 150 | - | Rocol Foodlube Hi-Torque 320 |
| BP | Enerpar M 32 | Enerpar M 46 | Enerpar M 68 | - | - | - |
| KLÜBER | Summit Hysyn FG 32 | Summit Hysyn FG 46 | Summit Hysyn FG 68 | Klüberoil 4 UH1 N 150 | Klüberoil 4 UH1 N 220 | Klüberoil 4 UH1 N 320 |
| MOBIL | DTE FM 32 | DTE FM 46 | DTE FM 68 | DTE FM 150 | DTE FM 220 | DTE FM 320 |
| SHELL | Cassida Fluid HF 32 | Cassida Fluid HF 46 | Cassida Fluid HF 68 | Cassida Fluid GL 150 | Cassida Fluid GL 220 | Cassida Fluid GL 320 |
| TEXACO | Cygnus Hydraulic Oil 32 | Cygnus Hydraulic Oil 32 | Cygnus Hydraulic Oil 32 | Cygnus Gear PAO 150 | Cygnus Gear PAO 220 | - |
| TOTAL | Nevastane AW 32 | Nevastane AW 46 | Nevastane AW 68 | Nevastane SL 150 | Nevastane SL 220 | Nevastane SL 320 |
| TRIBOL | Food Proof 1840/32 | Food Proof 1840/ 46 | Food Proof 1840/68 | - | Food Proof 1810/220 | Food Proof 1810/320 |

Si on utilise d'autres lubrifiants synthétiques, vérifier leur compatibilité avec les joints étanches à l'huile en NBR présents dans le réducteur.

En caso de utilización de otros lubricantes sintéticos, comprobar la compatibilidad con los sellos de aceite de NBR presentes en el reductor.

No caso de emprego de outros lubrificantes sintéticos, verificar a compatibilidade com as vedações do óleo em NBR presentes no redutor.



Ne pas mélanger des lubrifiants synthétiques de types différents.

No mezclar lubricantes sintéticos de diferentes tipos.

Não misturar lubrificantes sintéticos de tipo diferente.

Si les conditions de service du réducteur prévoient des périodes de fonctionnement prolongées entraînant une température de l'huile élevée (>60°C) il est conseillé d'utiliser de l'huile synthétique, pour que les composants s'usent moins rapidement et par conséquent distancier les substitutions qui s'avèrent tôt ou tard nécessaires.

Si las condiciones de funcionamiento del reductor prevén largos periodos de funcionamiento tales que se produzcan altas temperaturas del aceite (>60°C), se aconseja utilizar aceite sintético, para garantizar un menor desgaste de los componentes y aumentar los intervalos de sustitución.

Se as condições de exercício do redutor prevêem longos períodos de funcionamento que possam produzir uma elevada temperatura do óleo (> 60 °C) aconselhamos o uso de óleo sintético, para garantir um menor desgaste dos componentes e aumentar os intervalos de substituição.

La température maximum du lubrifiant dans le réducteur ne doit pas dépasser 90°C.

La temperatura máxima del lubricante dentro del reductor no debe superar los 90°C.

A temperatura máxima do lubrificante no interior do redutor não deve ultrapassar os 90°C.

6.4 Positions de montage et disposition des bouchons

Les figures ci-dessous montrent les possibilités de positionnement de montage, dont il faut indiquer le sigle au moment de la commande du réducteur.

La disposition et la typologie des bouchons et le niveau minimum de lubrifiant sont aussi indiqués, comme le montre la légende.

Attention:

En cas de services continus (de 24 heures) nous vous conseillons d'utiliser des bouchons d'évent avec le labyrinthe et le filtre fritté ensemble à une colonnette.

6.4 Posiciones de montaje y ubicación de los tapones

En las figuras siguientes se muestran las posibles posiciones de montaje, cuya sigla se debe especificar en el pedido del reductor.

Además se indican la ubicación y el tipo de los tapones y el nivel mínimo de lubricante, conforme a las explicaciones.

¡Atención!

Para servicios continuados (24h) aconsejamos utilizar tapones con respiradero con el laberinto y el filtro sinterizado junto con un racor.

6.4 Posições de montagem e disposição dos tampões

Nas figuras seguintes estão ilustradas as possíveis posições de montagem, cuja referência deve ser especificada na fase de encomenda do redutor.

Além disso, também estão indicados a disposição, o tipo de tampões e o nível mínimo de lubrificante, como ilustrado na legenda.

Atenção!

Para os serviços em curso (24 horas) recomendamos o uso de tampões ventilados labirinto com filtro sinterizado e com uma coluna.

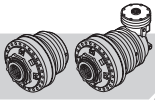

- ① Carico e sfiato
Filling up and venting
Füllen und Entlüften
- ② Livello
Level
Ölstand
- ③ Scarico
Drainage
Ablass
- ④ Sfiato durante il carico
Venting while filling up
Entlüften beim Füllen
- Livello minimo
Minimum level
Mindestölstand

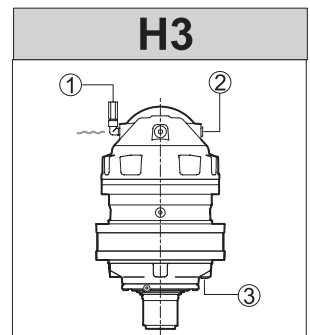
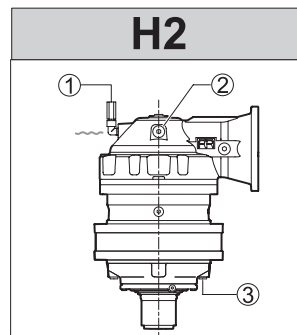
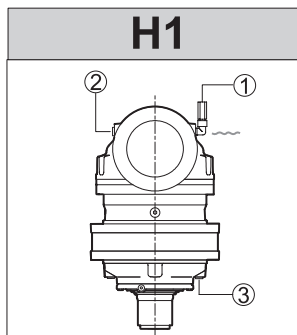
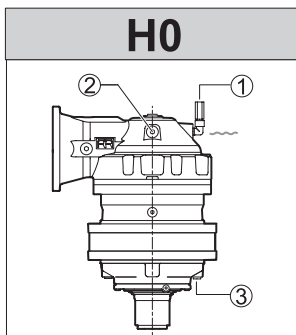
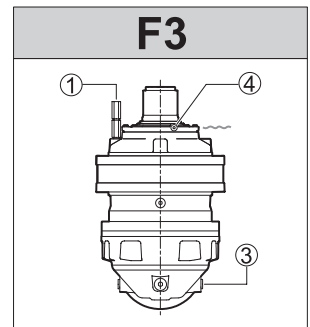
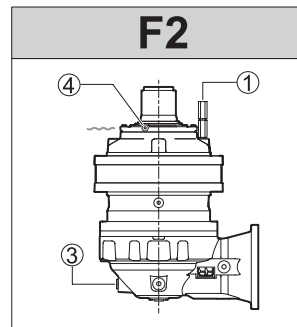
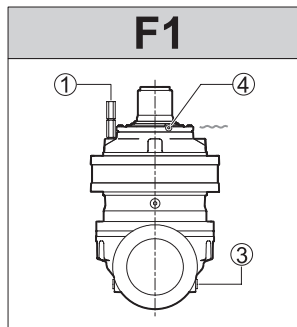
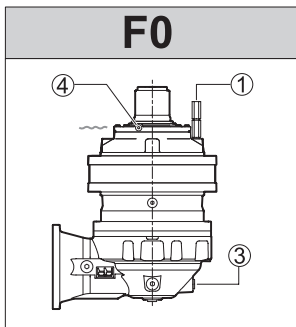
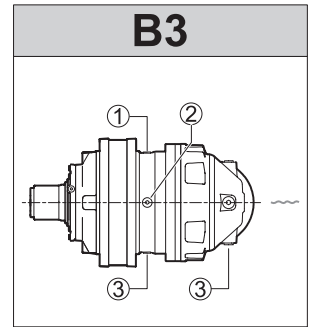
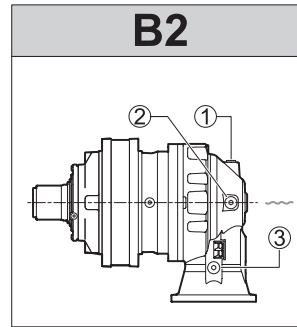
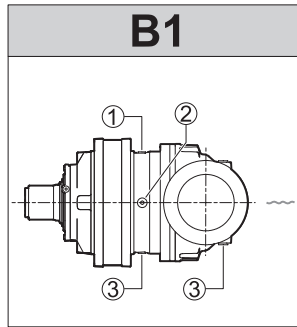
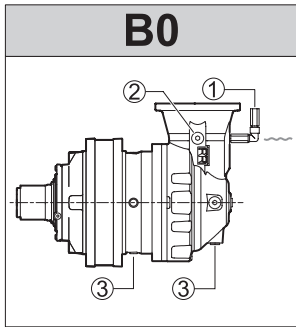
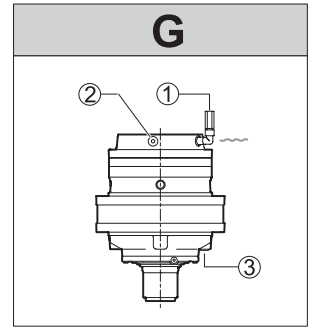
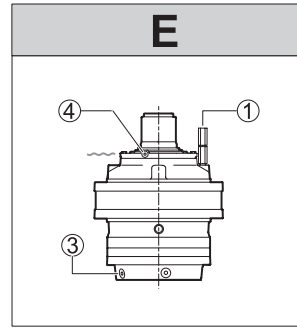
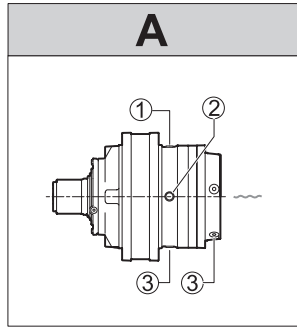

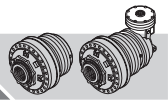

- ① Nourissage et évent
Carga y purga
Carga e resfolgo
- Niveau
- ② Nivel
Nivel
- Vidange
- ③ Descarga
Esvazamiento
- Event pendant le nourissage
Purga durante la carga
Resfolgo durante a carga
- ④ Niveau minimum
Nivel mínimo
- ~ Nivel mínimo

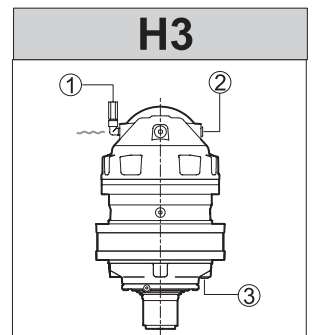
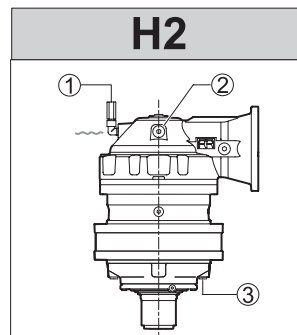
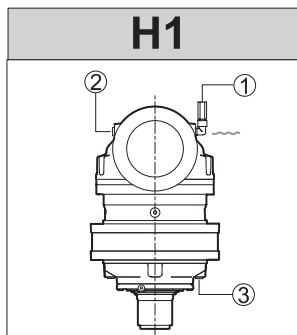
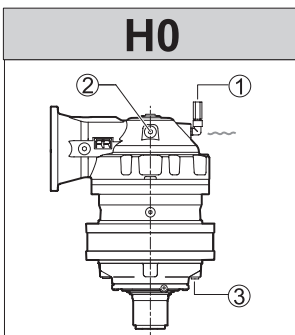
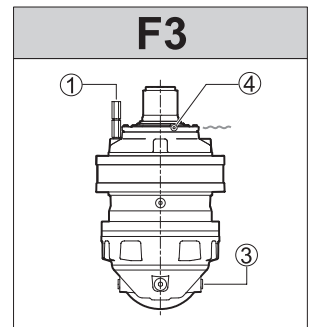
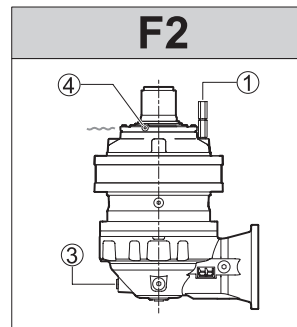
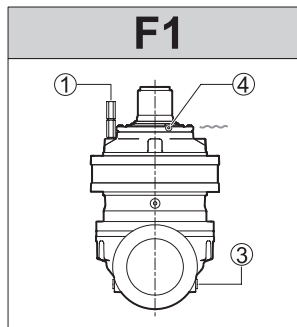
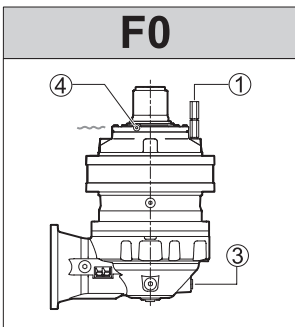
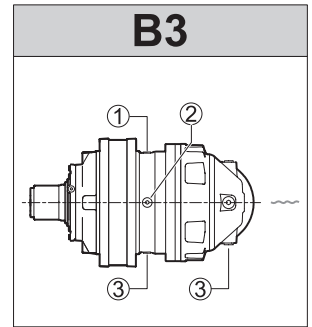
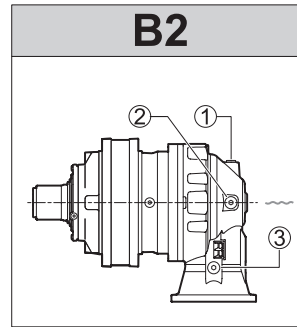
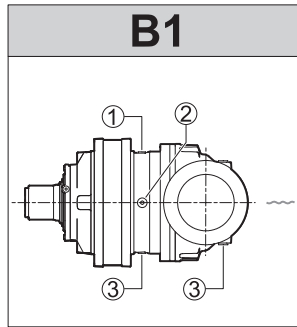
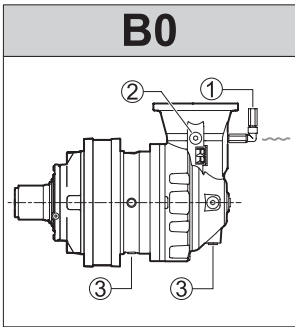
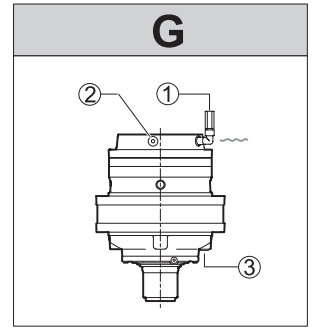
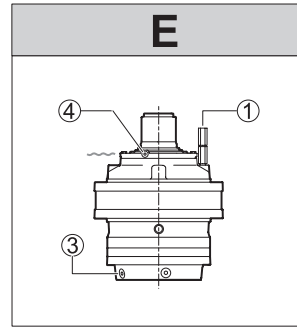
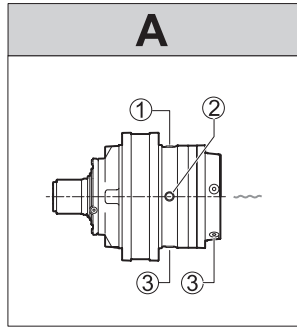

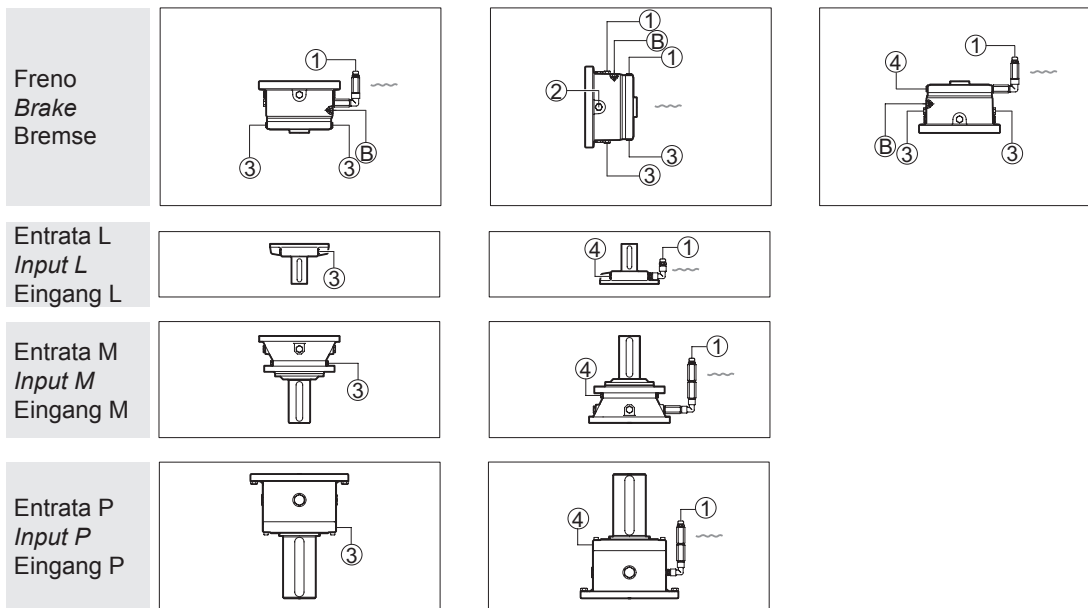
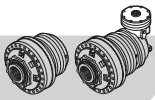

- ① Carico e sfiato
Filling up and venting
Füllen und Entlüften
- ② Livello
Level
Ölstand
- ③ Scarico
Drainage
Ablass
- ④ Sfiato durante il carico
Venting while filling up
Entlüften beim Füllen
- ⓑ Comando apertura freno
Brake opening control
Steuerung Bremsenöffnung
- ~~~~ Livello minimo
Minimum level
Mindestölstand

6.5 Riempimento

Per le posizioni di montaggio A, B1, B2 e B3 il riempimento va effettuato fino alla mezzieria del riduttore; il corretto livello del lubrificante può essere verificato mediante gli appositi tappi di livello, indicati con (2) nella figura precedente.

Per le posizioni di montaggio E, G, B0, F0, F1, F2, F3, H0, H1, H2 e H3, è necessario effettuare il completo riempimento, in modo da consentire la corretta lubrificazione dei componenti posti nella parte più alta del riduttore. In questo caso durante il riempimento occorre rimuovere almeno uno dei tappi posti nella parte più alta del riduttore, indicati con (4) nella figura precedente, in modo da evitare la formazione di bolle d'aria.

6.5 Filling up

For the assembly positions A, B1, B2 and B3 fill up to the halfway point of the reduction gear; the right level of the lubricant can be checked with the level plugs, indicated with (2) in the previous figure.

For the assembly positions E, G, B0, F0, F1, F2, F3, H0, H1, H2 and H3, they have to be filled right up to the top to allow correct lubrication of the components situated at the upper most part of the reduction gear. In this case, when filling up, you have to remove at least one of the plugs from the upper most part of the reduction gear, indicated with (4) in the previous figure, so as to prevent air bubbles forming.

6.5 Einfüllen vom Öl

Bei den Montagepositionen A, B1, B2 und B3 erfolgt das Einfüllen bis zur Mittellinie vom Planetengetriebe. Der korrekte Ölstand kann über die dafür vorgesehenen Ölstandsdeckel kontrolliert werden (siehe Abbildung oben (2)).

Bei den Montagepositionen E, G, B0, F0, F1, F2, F3, H0, H1, H2 und H3 ist eine komplette Füllung erforderlich, um die korrekte Schmierung der Teile an der höchsten Stelle im Planetengetriebe zu garantieren. In diesem Fall muss beim Einfüllen mindestens einer der Deckel oben (Abbildung oben (4)) abgenommen werden, damit sich keine Luftblasen bilden.

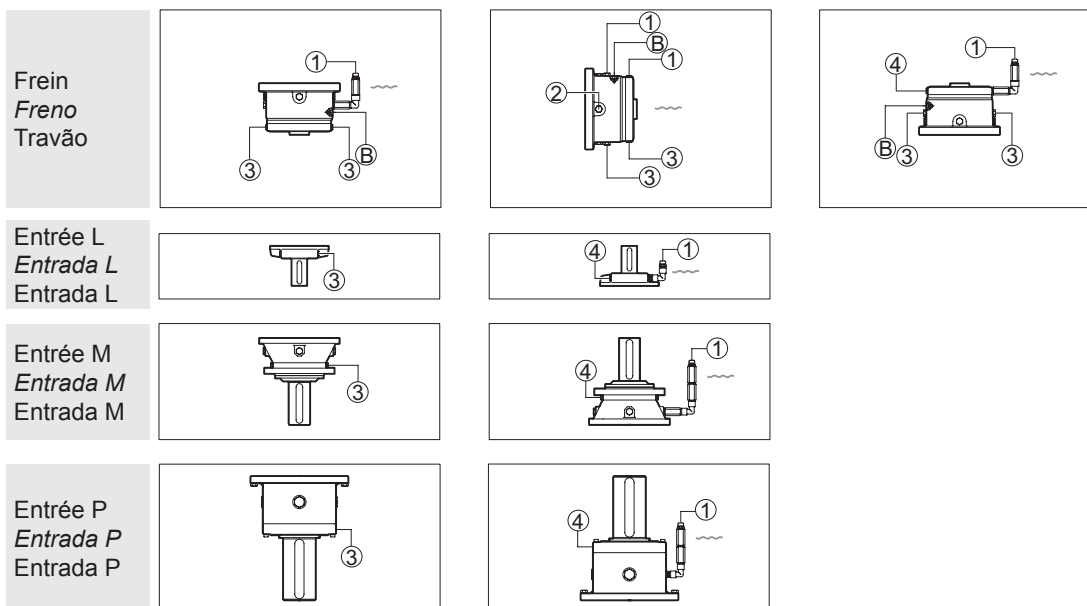
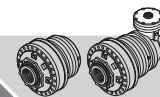

- ① Nourissage et évent
Carga y purga
Carga e resfolgo
- ② Niveau
Nivel
Nível
- ③ Vidange
Descarga
Esvazamiento
- ④ Event pendant le nourissage
Purga durante la carga
Resfolgo durante a carga
- Ⓑ Commande d'ouverture du frein
Mando apertura freno
Comando abertura travão
- ~~~~ Niveau minimum
Nivel mínimo
Nível mínimo

6.5 Nourissage

Pour les positions de montage A, B1, B2 et B3 le nourissage doit être fait jusqu'à la ligne médiane du réducteur; le niveau correct de lubrifiant peut être vérifié à l'aide de jauges, indiquées par un (2) sur la figure précédente.

Pour les positions de montage E, G, B0, F0, F1, F2, F3, H0, H1, H2 et H3, il est nécessaire d'effectuer un nourissage complet, pour permettre la bonne lubrification des composants se trouvant dans la partie la plus haute du réducteur. Dans ce cas, pendant le nourissage, enlever au moins l'un des bouchons se trouvant dans la partie la plus haute du réducteur, indiqués par un (4) sur la figure précédente, de manière à éviter la formation de bulles d'air.

6.5 Llenado

Para las posiciones de montaje A, B1, B2 y B3 el llenado se debe efectuar hasta la línea mediana del reductor; el nivel correcto del lubricante se puede comprobar a través de los correspondientes tapones de nivel, indicados con (2) en la figura precedente.

Para las posiciones de montaje E, G, B0, F0, F1, F2, F3, H0, H1, H2 y H3, es necesario efectuar un llenado completo, para consentir la lubricación correcta de los componentes situados en la parte más alta del reductor. En este caso, durante el llenado es preciso quitar por lo menos uno de los tapones situados en la parte más alta del reductor, indicados con (4) en la figura precedente, a fin de evitar que se formen burbujas de aire.

6.5 Enchimento

Para as posições de montagem A, B1, B2 e B3 o enchimento deve ser efetuado até metade do redutor; o correto nível do lubrificante pode ser verificado através dos respetivos tampões de nível, indicados como (2) na figura precedente.

Para as posições de montagem E, G, B0, F0, F1, F2, F3, H0, H1, H2 e H3, é necessário efetuar o enchimento completo, de modo a consentir a correta lubrificação dos componentes situados na parte mais elevada do redutor. Neste caso durante o enchimento é necessário retirar pelo menos um dos tampões situados na parte mais elevada do redutor, indicados com (4) na figura precedente, de modo a evitar a formação de bolhas de ar.

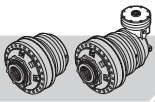

Poiché il lubrificante aumenta il suo volume al crescere della temperatura, quando il riduttore lavora in condizioni di pieno riempimento è necessario predisporre un serbatoio che permetta l'espansione dell'olio e riduca il rischio di pressioni elevate all'interno del riduttore stesso.

Per agevolare l'operazione di riempimento e allo stesso tempo consentire l'espansione dell'olio sono disponibili, a richiesta, degli appositi vasi di espansione, di diverse capacità e fornibili anche sotto forma di kit completo. Tali vasi di espansione possono essere collegati al riduttore mediante connessione rigida o mediante tubi flessibili.

Il vaso di espansione deve essere sempre collocato in modo che il livello dell'olio, visualizzabile ad esempio mediante un tubicino trasparente posto in parallelo con il vaso (di serie per alcuni kit), si trovi al di sopra della zona più alta che si vuole lubrificare e quindi dei tappi di sfiato (4).

As the lubricant increases in volume with the rising temperature, when the reduction gear is working in the completely filled conditions it is necessary to have a tank that allows the oil to expand and thus reduce the risk of high pressures being created inside the reduction gear itself.

To facilitate filling up and, at the same time, allow the oil to expand, expansion tanks are available on request with different capacities and supplied in complete kits. These expansion tanks can be connected to the reduction gear with a rigid connection or flexible pipes.

The expansion tank must always be placed so the level of oil, which can be seen by means of a small transparent tube placed in parallel with the tank for instance (standard in some kits), is above the highest point you wish to lubricate and, hence, above the venting plugs (4).

Da das Schmiermittel mit steigender Temperatur an Volumen gewinnt, muss ein Behälter bereitgestellt werden, der die Ölausdehnung erlaubt und das Risiko hoher Drücke im Planetengetriebe verhindert, wenn mit voller Füllung gearbeitet wird.

Um das Einfüllen zu erleichtern und die Ölausdehnung zu ermöglichen, sind auf Wunsch entsprechende Ausdehnungsgefäße mit unterschiedlichem Fassungsvermögen lieferbar, die auch als kompletter Kit erhältlich sind. Diese Ausdehnungsgefäße können über steife Leitungen oder Schläuche an das Planetengetriebe angeschlossen werden.

Das Ausdehnungsgefäß muss so positioniert sein, dass sich der Ölstand, der zum Beispiel über eine durchsichtige Ölstandsanzeige parallel zum Gefäß (serienmäßig bei einigen Kits) angezeigt wird, oberhalb der höchsten Stelle befindet, die geschmiert werden soll, und damit oberhalb der Entlüftungsdeckel (4).

- ① Carico e sfiato
Filling up and venting
Füllen und Entlüften
- ④ Sfiato durante il carico
Venting while filling up
Entlüften beim Füllen
- ~ Livello minimo
Minimum level
Mindestölstand

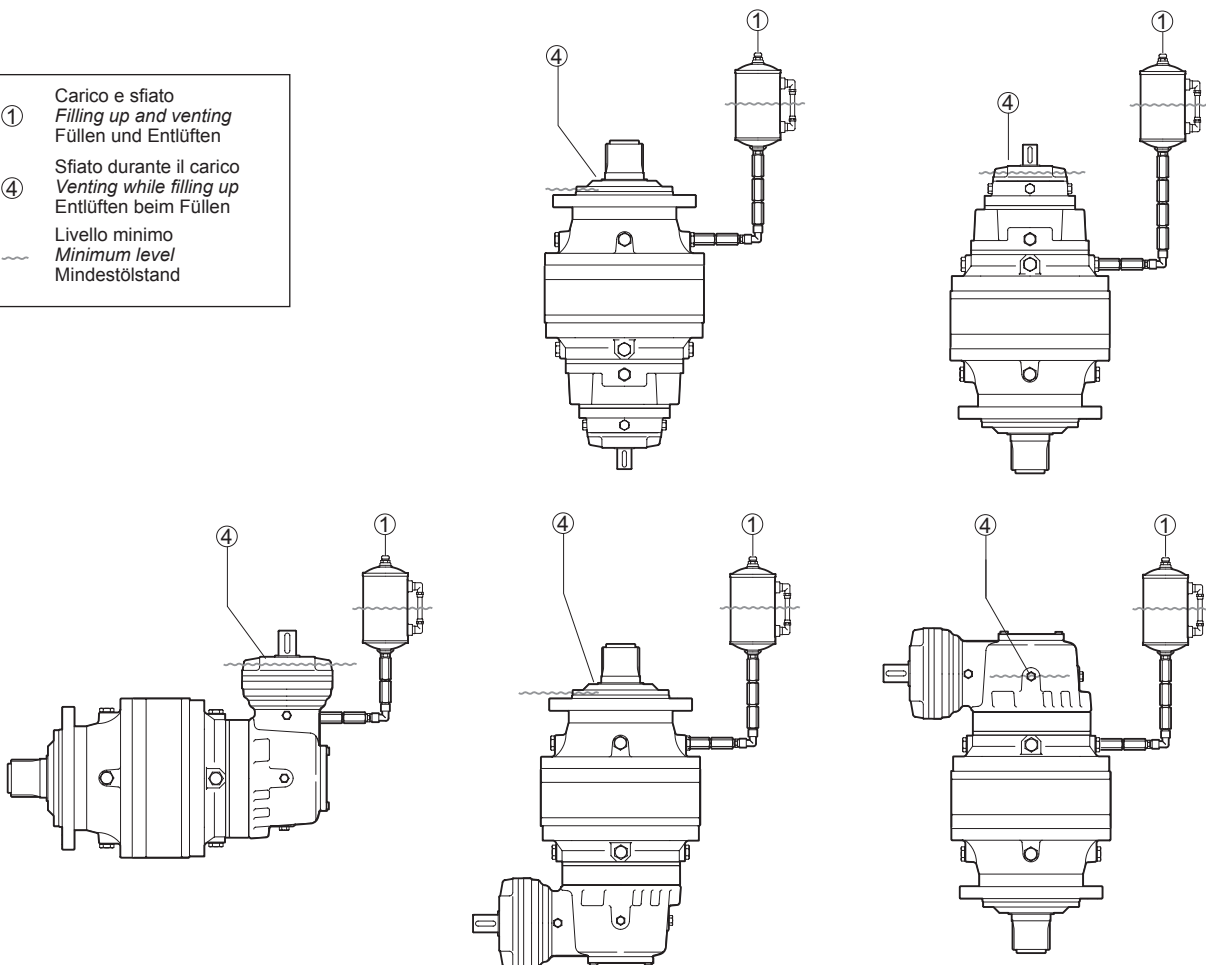



Le lubrifiant augmentant son volume si la température monte, quand le réducteur fonctionne dans des conditions de nourrissage complet, il faut prévoir un réservoir permettant l'expansion de l'huile et la réduction du risque de pressions élevées dans le réducteur.

Pour faciliter l'opération de nourrissage et permettre l'expansion de l'huile, il existe, en option, des vases d'expansion, de différentes capacités et livrables aussi sous forme de kit complet. Ces vases d'expansion peuvent être raccordés au réducteur par des raccords rigides ou des tubes flexibles.

Le vase d'expansion doit toujours être positionné de manière que le niveau de l'huile, qu'on peut contrôler par exemple grâce à un petit tube transparent se trouvant parallèlement au vase (certains kits en sont déjà équipés dès leur sortie d'usine), soit dans la zone la plus haute qu'on veut lubrifier et par conséquent au-dessus des évents (4).

Puesto que el lubricante aumenta su volumen al aumentar la temperatura, cuando el reductor trabaja en condiciones de completo llenado es necesario predisponer un depósito que permita la expansión del aceite y reduzca el riesgo de altas presiones dentro del propio reductor.

Para facilitar la operación de llenado y al mismo tiempo consentir la expansión del aceite, hay disponibles, bajo pedido, unos idóneos vasos de expansión, con diferentes capacidades y suministrables también en forma de kit completo. Dichos vasos de expansión se pueden conectar con el reductor mediante conexión rígida o mediante mangueras flexibles.

El vaso de expansión debe estar situado siempre de manera que el nivel del aceite, visualizable por ejemplo a través de un tubito transparente puesto en paralelo con el vaso (de serie con algunos kits), esté por encima de la zona más alta que se desea lubricar y por lo tanto de los tapones purgadores (4).

Dado que o lubrificante aumenta o seu volume ao aumentar da temperatura, quando o reductor trabalha em condições de enchimento completo é necessário predispor um depósito que consinta a expansão do óleo e reduza o risco de pressões elevadas no interior do próprio reductor.

Para facilitar a operação de enchimento e ao mesmo tempo consentir a expansão do óleo são disponíveis, a pedido, alguns depósitos de expansão, de vária capacidade e que também são fornecidos sob forma de kit completo. Estes vasos de expansão podem ser ligados ao reductor mediante ligação rígida ou mediante tubos flexíveis.

O vaso de expansão deve ser sempre colocado de modo a que o nível do óleo, visualizável, por exemplo através de um tubinho transparente situado em paralelo com o depósito (de série nalguns kits), se encontre acima da zona mais alta que se deseja lubrificar e portanto dos tampões de resfolgo (4).

| | |
|---|--|
| ① | Nourissage et évent Carga y purga Carga e resfolgo |
| ④ | Event pendant le nourrissage Purga durante la carga Resfolgo durante a carga |
| — | Niveau minimum Nivel mínimo Nível mínimo |

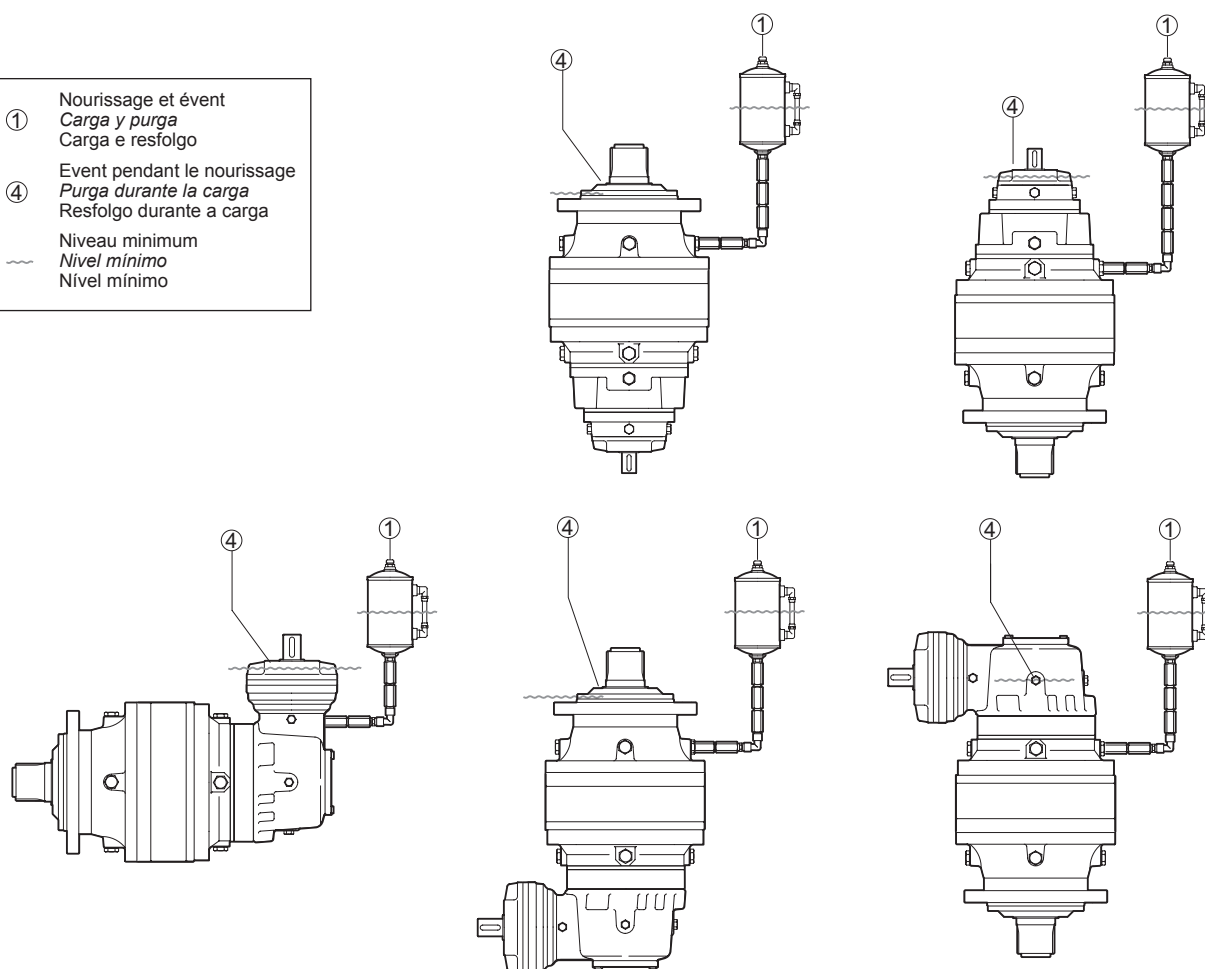

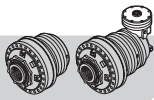

Fare riferimento alla seguente tabella e alla relativa figura per conoscere i codici di vendita e i dati tecnici dei kit serbatoio.

Please refer to the following table and relative figure for the sales codes and technical specifications of the tank kits.

Die Bestellnummern und technischen Daten der Kits für Ausdehnungsgefäße können der Tabelle unten und der dazugehörigen Abbildung entnommen werden.

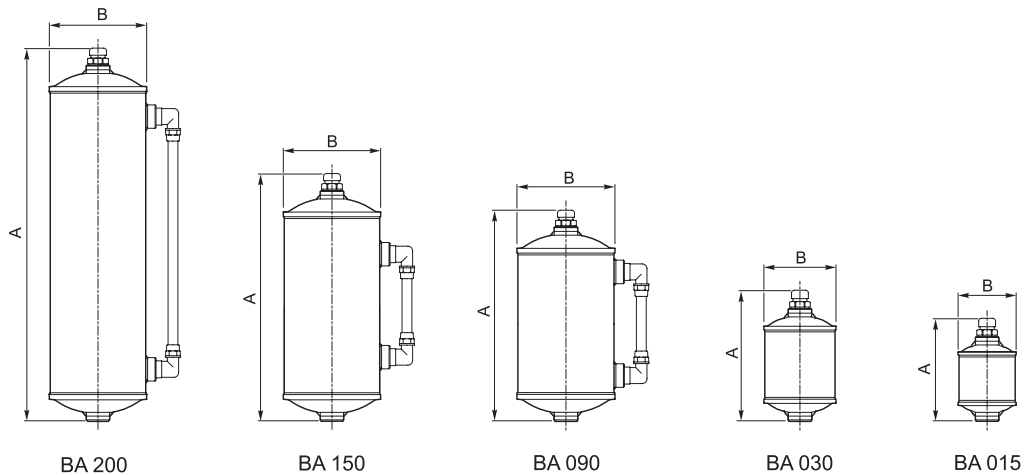

| Tipo / Type / Typ | A | B | Capacità / Capacity Fassung-vermögen [l] | Codice / Code / Code | |
|-------------------|-----|-----|---|---|------------------------------------|
| | | | | Kit completo Code of the complete kit Bestellnr. kompletter | Serbatoio Tank code Behälter |
| BA 015 | 110 | 65 | ~ 0.15 | 154-5764 | 154F1562 |
| BA 030 | 140 | 80 | ~ 0.30 | 154-5749 | 154F1563 |
| BA 090 | 225 | 104 | ~ 0.90 | 154-5733 | 154F1561 |
| BA 150 | 265 | 104 | ~ 1.50 | 154F5986 | 154F5988 |
| BA 200 | 400 | 104 | ~ 2.00 | 154F5987 | 154F5989 |

La scelta del serbatoio va fatta in base al volume di olio espanso V_e ; questo si può determinare nel seguente modo: individuare sul grafico che segue il punto che ha per ascissa la differenza Δt tra la temperatura dell'olio del riduttore e la temperatura ambiente e per ordinata il volume V di olio necessario al riempimento del riduttore. In base alla zona del grafico in cui cade il punto si determina il volume di olio espanso V_e e si dimensiona il serbatoio per un volume doppio rispetto a quello calcolato.

The choice of tank should be based on the volume of expanded oil V_e ; this can be found in the following way: in the following graph, find the point which has Δt difference between the reduction gear's oil temperature and ambient temperature as the abscissa and volume V of oil necessary to fill the reduction gear as the ordinate. On the basis of the area in which the point falls, you find the volume of expanded oil V_e and the tank is sized for double the volume calculated.

Für die Auswahl vom Behälter ist das Volumen vom ausgedehnten Öl V_e entscheidend, das wie folgt ermittelt werden kann: Auf der Grafik den Punkt ermitteln, dessen X-Koordinate die Differenz Δt zwischen der Öltemperatur im Getriebe und der Umgebungstemperatur ist und dessen Y-Koordinate das Volumen V vom Öl, das zum Füllen vom Getriebe erforderlich ist. Anhand des Bereichs auf der Grafik, in den der Punkt fällt, kann das Volumen V_e vom ausgedehnten Öl ermittelt werden. Der Behälter wird dann auf das doppelte Volumen des errechneten Werts ausgelegt.

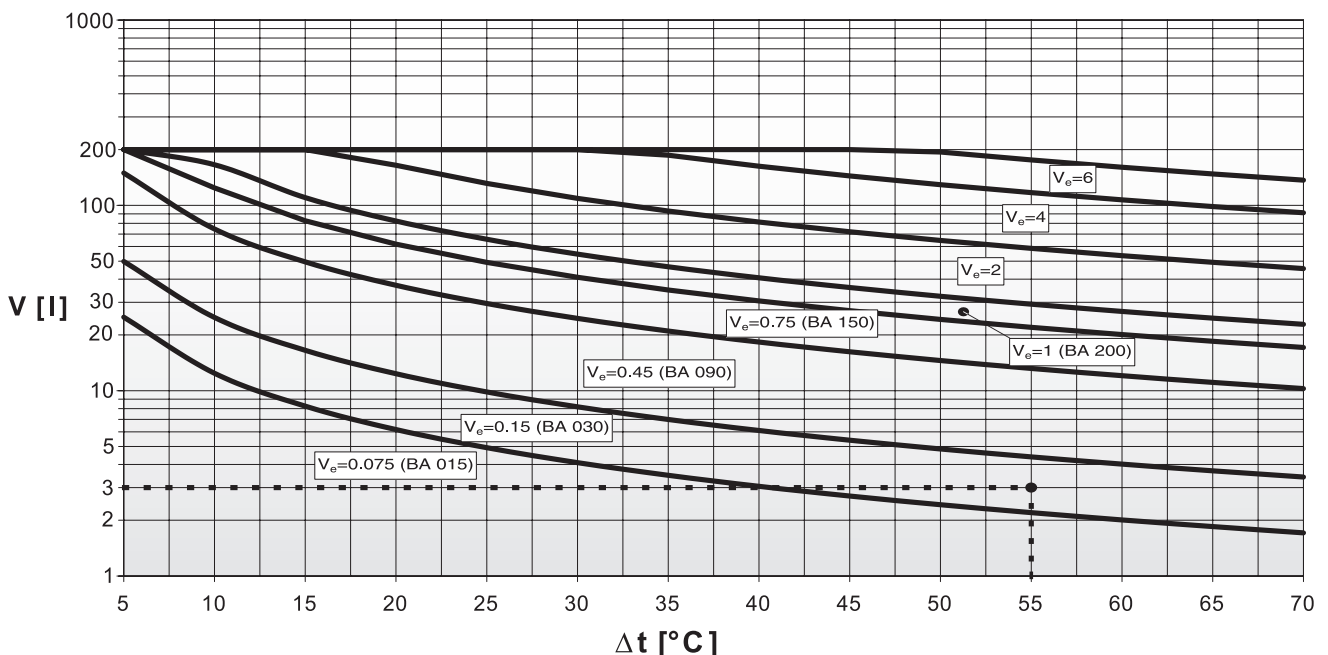



Voir le tableau suivant et la figure correspondante pour connaître les codes de vente et les caractéristiques techniques des kits réservoir.

Hágase referencia a la siguiente tabla y a la correspondiente figura para conocer los códigos de venta y los datos técnicos de los kits depósito.

Consultar a seguinte tabela e a relativa figura para conhecer os códigos de venda e os dados técnicos dos kits depósito.

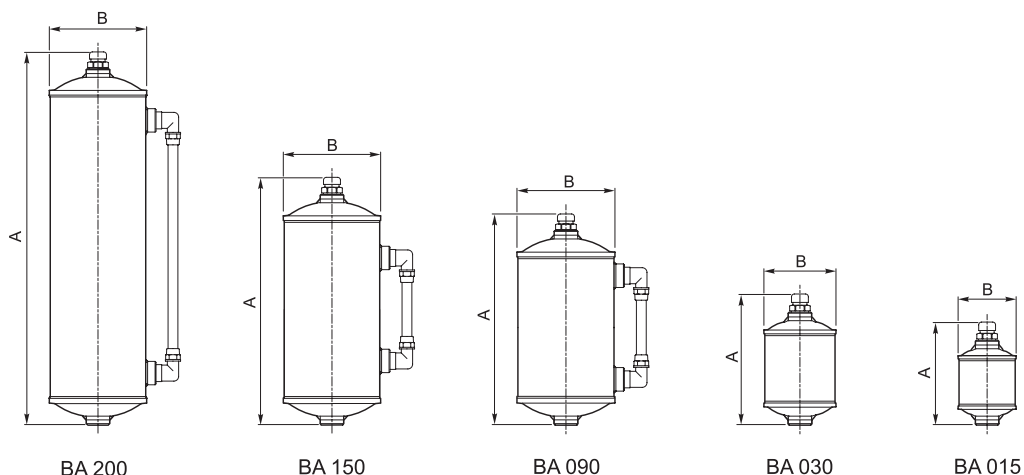

| Type / Tipo / Tipo | A | B | Contenance Capacidad Capacidade [l] | Code / Código / Code | |
|--------------------|-----|-----|--|---|-----------------------------------|
| | | | | Kit complet Kit completo Kit completo | Réservoir Depósito Depósito |
| BA 015 | 110 | 65 | ~ 0.15 | 154-5764 | 154F1562 |
| BA 030 | 140 | 80 | ~ 0.30 | 154-5749 | 154F1563 |
| BA 090 | 225 | 104 | ~ 0.90 | 154-5733 | 154F1561 |
| BA 150 | 265 | 104 | ~ 1.50 | 154F5986 | 154F5988 |
| BA 200 | 400 | 104 | ~ 2.00 | 154F5987 | 154F5989 |

Le choix du réservoir se fait en fonction du volume d'huile expansé V_e ; ce volume peut être déterminé de la manière suivante : trouver sur le graphique ci-dessous le point qui a pour abscisse la différence Δt entre la température de l'huile du réducteur et la température ambiante et pour ordonnée le volume V d'huile nécessaire au nourrissage du réducteur. En fonction de la zone du graphique où tombe le point, on détermine le volume d'huile expansé V_e et on choisit les dimensions du réservoir sur la base d'un volume double par rapport au volume calculé.

El depósito se debe seleccionar sobre la base del volumen de aceite expandido V_e ; lo que se puede determinar de la siguiente manera: Individuar, en el gráfico siguiente, el punto que tiene por abscisa la diferencia Δt entre la temperatura del aceite del reductor y la temperatura ambiente y por ordenada el volumen V de aceite necesario para llenar el reductor. En base a la zona del gráfico en la cual cae el punto, se determina el volumen de aceite expandido V_e y se dimensiona el depósito para un volumen doble con respecto al calculado.

A escolha do depósito deve ser feita segundo o volume de óleo expandido V_e ; podendo ser determinado no seguinte modo: identificar no gráfico que segue o ponto que tem por abscissa a diferença Δt entre a temperatura do óleo do redutor e a temperatura ambiente e por ordenada o volume V de óleo necessário para encher o redutor. Segundo a zona do gráfico em que se encontra o ponto, determina-se o volume de óleo expandido V_e e dimensiona-se o depósito para um volume duplo respeito àquele calculado.

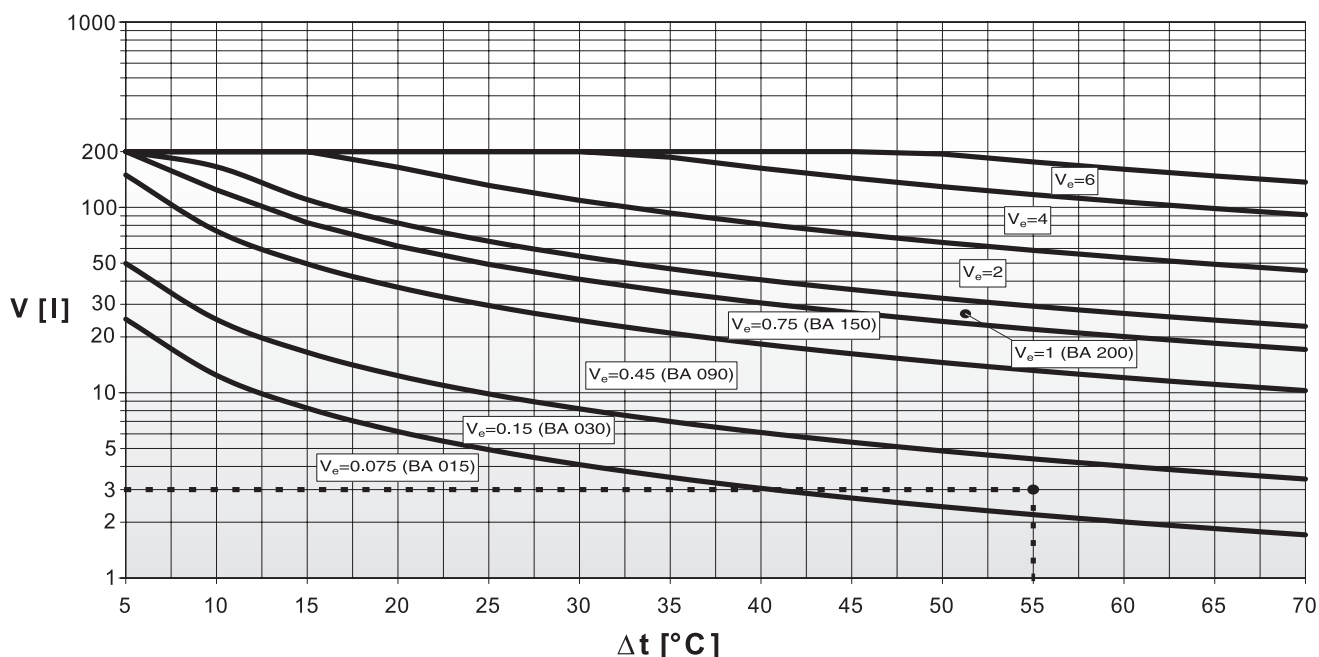

Δt [°C]



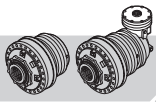

Esempio

Si consideri un riduttore con capacità olio di 3 litri alla temperatura di esercizio di 80°C, con temperatura ambiente di 25°C.

Individuando sul grafico il punto di ascissa $\Delta t = 80-25 = 55^\circ\text{C}$ ed ordinata $V = 3$ litri, questo appartiene alla zona con volume espanso $V_e = 0,15$ litri. Il serbatoio consigliato dovrà avere un volume doppio rispetto a V_e cioè 0,30 litri e dunque il serbatoio idoneo è il BA 030.

Example

Consider a reduction gear with an oil capacity of 3 litres at an operating temperature of 80°C and with an ambient temperature of 25°C.

Finding the abscissa $\Delta t = 80-25 = 55^\circ\text{C}$ and ordinate $V = 3$ litres point on the graph, it belongs to the area with an expanded volume of $V_e = 0,15$ litres. The tank recommended should have a volume double that of V_e - that is 0.30 litres - so the ideal tank is the BA 030.

Beispiel

Es wird von einem Getriebe mit einem Ölfassungsvermögen von 3 Litern bei Betriebstemperatur 80°C und Umgebungstemperatur 25°C ausgegangen.

Es wird ein Punkt mit der X-Koordinate $\Delta t = 80-25 = 55^\circ\text{C}$ und der Y-Koordinate $V = 3$ ermittelt, der in den Bereich mit ausgedehntem Volumen von $V_e = 0,15$ Liter fällt. Der Behälter sollte das Doppelte von V_e fassen, also 0,30 Liter. Geeignet ist damit der Behälter BA 030.

Nelle pagine seguenti sono indicati i volumi di olio, puramente indicativi, necessari per il riempimento, in funzione della posizione di montaggio.

Per i dati mancanti contattare il Servizio Tecnico Reggiana Riduttori.

On the following pages you will find the volumes of oil, purely indicative, necessary to fill up according to the assembly position.

For any data you cannot find, please contact the Reggiana Riduttori Technical Service.

Auf den folgenden Seiten sind reine Richtwerte für die Ölmengen angegeben, die zum Füllen in der entsprechenden Montageposition erforderlich sind.

Fehlende Werte erhalten Sie beim Technischen Kundendienst von Reggiana Riduttori.

| Tipo / Type / Typ | Volume olio Oil volume Ölmenge [l] | | | Massa Mass Gewicht [kg] |
|-------------------|--|---|---|-------------------------------|
| | Posizione / Position / Position | | | |
| | A | E | G | |

| | | | | |
|--------|-----|-----|-----|-----|
| RR65 | M.. | 0.1 | 0.2 | 7 |
| | FS | 0.1 | 0.2 | 3.5 |
| RR65D | M.. | 0.1 | 0.3 | 10 |
| | FS | 0.1 | 0.2 | 5.5 |
| RR65T | M.. | 0.2 | 0.3 | 12 |
| | FS | 0.1 | 0.3 | 6.8 |
| RR105 | M.. | 0.5 | 0.9 | 14 |
| | FS | 0.4 | 0.8 | 8 |
| RR105D | M.. | 0.3 | 0.6 | 20 |
| | FS | 0.2 | 0.5 | 9 |
| RR105T | M.. | 0.3 | 0.7 | 21 |
| | FS | 0.2 | 0.5 | 14 |
| RR110 | M.. | 0.5 | 0.9 | 11 |
| | FS | 0.4 | 0.8 | 7.5 |
| RR110D | M.. | 0.3 | 0.6 | 15 |
| | FS | 0.2 | 0.5 | 9 |
| RR110T | M.. | 0.3 | 0.7 | 18 |
| | FS | 0.2 | 0.5 | 15 |
| RR210 | M.. | 0.5 | 0.9 | 24 |
| | S.. | 0.5 | 1.0 | 21 |
| | FS | 0.4 | 0.8 | 9 |
| RR210D | M.. | 0.6 | 1.2 | 25 |
| | S.. | 0.6 | 1.2 | 25 |
| | FS | 0.5 | 1.0 | 14 |
| RR210T | M.. | 0.4 | 0.9 | 27 |
| | S.. | 0.5 | 0.9 | 49 |
| | FS | 0.4 | 0.7 | 22 |
| RR210Q | M.. | 0.5 | 0.9 | 28 |
| | S.. | 0.5 | 0.9 | 50 |
| | FS | 0.4 | 0.7 | 23 |

| Tipo / Type / Typ | Volume olio Oil volume Ölmenge [l] | | | | Massa Mass Gewicht [kg] |
|-------------------|--|----------------------|----------------------|----------------|-------------------------------|
| | Posizione / Position / Position | | | | |
| | B0 | F0 F1 F2 F3 | H0 H1 H2 H3 | B1 B2 B3 | |

| | | | | |
|--------|-----|-----|-----|----|
| RA105 | M.. | 2.4 | 1.2 | 33 |
| | FS | 2.2 | 1.1 | 30 |
| RA105D | M.. | 2.1 | 1.0 | 37 |
| | FS | 1.9 | 0.9 | 32 |
| RA110 | M.. | 2.4 | 1.2 | 33 |
| | FS | 2.2 | 1.1 | 31 |
| RA110D | M.. | 2.1 | 1.0 | 35 |
| | FS | 1.9 | 0.9 | 32 |
| RA210 | M.. | 2.4 | 1.2 | 32 |
| | S.. | 2.4 | 1.2 | 38 |
| RA210D | FS | 2.2 | 1.1 | 33 |
| | M.. | 2.6 | 1.3 | 35 |
| | S.. | 2.7 | 1.3 | 42 |
| FS | 2.4 | 1.2 | 34 | |

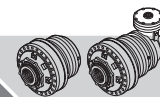
**Exemple**

Si l'on considère un réducteur d'une contenance de 3 litres d'huile à la température de fonctionnement de 80°C, avec une température ambiante de 25°C, et que l'on trouve sur le graphique le point d'abscisse $\Delta t = 80 - 25 = 55^\circ\text{C}$ et d'ordonnée $V = 3$ litres, il appartient à la zone avec volume expansé $V_e = 0,15$ litres. Le réservoir conseillé devra avoir un volume double par rapport à V_e , c'est-à-dire 0,30 litres et par conséquent le réservoir adéquat est le BA 030.

Sur les pages suivantes se trouvent les indications concernant les volumes d'huile, donnés à titre purement indicatif, nécessaires au nourrissage, en fonction de la position de montage.
Pour les données manquantes, contacter le service technique Reggiana Riduttori.

Ejemplo

Consideremos un reductor con una capacidad de aceite de 3 litros a la temperatura de funcionamiento de 80°C, con temperatura ambiente de 25°C.

Individuando en el gráfico el punto de abscisa $\Delta t = 80 - 25 = 55^\circ\text{C}$ y ordenada $V = 3$ litros, pertenece a la zona con volumen expandido $V_e = 0,15$ litros. El depósito aconsejado deberá tener un volumen doble con respecto a V_e es decir 0,30 litros y por lo tanto el depósito idóneo será el BA 030.

En las páginas siguientes se indican los volúmenes de aceite, puramente indicativos, necesarios para el llenado, en función de la posición de montaje.
Para los datos faltantes cabe contactar con el Servicio Técnico de Reggiana Riduttori.

Exemplo

Considerando um redutor com capacidade de óleo de 3 litros à temperatura de exercício de 80°C, com temperatura ambiente de 25°C.

Identificando no gráfico o ponto de abscissa $\Delta t = 80 - 25 = 55^\circ\text{C}$ e ordenada $V = 3$ litros, o mesmo pertence à zona com volume expandido $V_e = 0,15$ litros. O depósito aconselhado deverá ter um volume duplo respeito a V_e ou seja 0,30 litros e portanto o depósito idóneo é o BA 030.

Nas páginas seguintes estão indicados os volumes de óleo, puramente indicativos, necessários para o enchimento, em função da posição de montagem.
No que diz respeito aos dados que faltam, contactar o Serviço Técnico Reggiana Riduttori.

| Type / Tipo / Tipo | Volume huile Volumen aceite Volume óleo [l] | | | Masse Masa Massa [kg] |
|--------------------|---|---|---|--------------------------------|
| | Position / Posición / Posição | | | |
| | A | E | G | |

| | | | | |
|--------|-----|-----|-----|-----|
| RR65 | M.. | 0.1 | 0.2 | 7 |
| | FS | 0.1 | 0.2 | 3.5 |
| RR65D | M.. | 0.1 | 0.3 | 10 |
| | FS | 0.1 | 0.2 | 5.5 |
| RR65T | M.. | 0.2 | 0.3 | 12 |
| | FS | 0.1 | 0.3 | 6.8 |
| RR105 | M.. | 0.5 | 0.9 | 14 |
| | FS | 0.4 | 0.8 | 8 |
| RR105D | M.. | 0.3 | 0.6 | 20 |
| | FS | 0.2 | 0.5 | 9 |
| RR105T | M.. | 0.3 | 0.7 | 21 |
| | FS | 0.2 | 0.5 | 14 |
| RR110 | M.. | 0.5 | 0.9 | 11 |
| | FS | 0.4 | 0.8 | 7.5 |
| RR110D | M.. | 0.3 | 0.6 | 15 |
| | FS | 0.2 | 0.5 | 9 |
| RR110T | M.. | 0.3 | 0.7 | 18 |
| | FS | 0.2 | 0.5 | 15 |
| RR210 | M.. | 0.5 | 0.9 | 24 |
| | S.. | 0.5 | 1.0 | 21 |
| | FS | 0.4 | 0.8 | 9 |
| RR210D | M.. | 0.6 | 1.2 | 25 |
| | S.. | 0.6 | 1.2 | 25 |
| | FS | 0.5 | 1.0 | 14 |
| RR210T | M.. | 0.4 | 0.9 | 27 |
| | S.. | 0.5 | 0.9 | 49 |
| | FS | 0.4 | 0.7 | 22 |
| RR210Q | M.. | 0.5 | 0.9 | 28 |
| | S.. | 0.5 | 0.9 | 50 |
| | FS | 0.4 | 0.7 | 23 |

| Type / Tipo / Tipo | Volume huile Volumen aceite Volume óleo [l] | | | | Masse Masa Massa [kg] |
|--------------------|---|----------------------|----------------------|----------------|--------------------------------|
| | Position / Posición / Posição | | | | |
| | B0 | F0 F1 F2 F3 | H0 H1 H2 H3 | B1 B2 B3 | |

| | | | | |
|--------|-----|-----|-----|----|
| RA105 | M.. | 2.4 | 1.2 | 33 |
| | FS | 2.2 | 1.1 | 30 |
| RA105D | M.. | 2.1 | 1.0 | 37 |
| | FS | 1.9 | 0.9 | 32 |
| RA110 | M.. | 2.4 | 1.2 | 33 |
| | FS | 2.2 | 1.1 | 31 |
| RA110D | M.. | 2.1 | 1.0 | 35 |
| | FS | 1.9 | 0.9 | 32 |
| RA210 | M.. | 2.4 | 1.2 | 32 |
| | S.. | 2.4 | 1.2 | 38 |
| RA210D | M.. | 2.6 | 1.3 | 35 |
| | S.. | 2.7 | 1.3 | 42 |
| RA210D | FS | 2.4 | 1.2 | 34 |

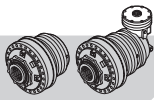

| Tipo / Type / Typ | Volume olio Oil volume Ölmenge [l] | | | Massa Mass Gewicht [kg] |
|-------------------|--|---|---|----------------------------------|
| | Posizione / Position / Position | | | |
| | A | E | G | |

| | | | | |
|--------|-----|-----|-----|------|
| RR310 | M.. | 1.1 | 2.1 | 21 |
| | S.. | 1.5 | 3.0 | 43 |
| | FS | 0.7 | 1.5 | 20 |
| RR310D | M.. | 1.2 | 2.4 | 36 |
| | S.. | 1.7 | 3.3 | 47 |
| | FS | 0.9 | 1.8 | 23 |
| RR310T | M.. | 1.1 | 2.1 | 38 |
| | S.. | 1.5 | 3.0 | 49 |
| | FS | 0.7 | 1.5 | 26.5 |
| RR310Q | M.. | 1.1 | 2.1 | 41 |
| | S.. | 1.5 | 3.0 | 53 |
| | FS | 0.7 | 1.5 | 29.5 |
| RR510 | M.. | 0.9 | 1.8 | 35 |
| | S.. | 1.4 | 2.7 | 44 |
| | FS | 0.6 | 1.2 | 28 |
| RR510D | M.. | 1.4 | 2.8 | 52 |
| | S.. | 1.9 | 3.7 | 60 |
| | FS | 1.1 | 2.1 | 37 |
| | VI | — | 2.5 | 51 |
| RR510T | M.. | 1.5 | 3.1 | 55 |
| | S.. | 2 | 4.0 | 61 |
| | FS | 1.2 | 2.4 | 39 |
| | VI | — | 2.8 | 54 |
| RR510Q | M.. | 1.4 | 2.8 | 59 |
| | S.. | 1.9 | 3.7 | 65 |
| | FS | 1.1 | 2.1 | 49 |
| | VI | — | 2.5 | 58 |
| RR710 | M.. | 0.9 | 1.8 | 34 |
| | S.. | 1.3 | 2.6 | 48 |
| | FS | 0.6 | 1.1 | 23 |
| RR710D | M.. | 1.4 | 2.8 | 54 |
| | S.. | 1.8 | 3.6 | 62 |
| | FS | 1 | 2.1 | 37 |
| | VI | — | 2.6 | 50 |
| RR710T | M.. | 1.5 | 3.1 | 56 |
| | S.. | 1.9 | 3.8 | 67 |
| | FS | 1.2 | 2.4 | 39 |
| | VI | — | 2.9 | 52 |
| RR710Q | M.. | 1.4 | 2.8 | 64 |
| | S.. | 1.8 | 3.5 | 75 |
| | FS | 1 | 2.1 | 47 |
| | VI | — | 2.6 | 60 |
| RR810 | M.. | 1.9 | 3.8 | 64 |
| | S.. | 2 | 4 | 70 |
| | FS | 1.4 | 2.8 | 41 |
| RR810D | M.. | 2.1 | 4.1 | 77 |
| | S.. | 2.1 | 4.3 | 81 |
| | FS | 1.6 | 3.1 | 61 |
| | VI | — | 5.9 | 81 |
| | ZI | — | 5.9 | 87 |
| RR810T | M.. | 2.2 | 4.4 | 83 |
| | S.. | 2.3 | 4.5 | 86 |
| | FS | 1.7 | 3.4 | 63 |
| | VI | — | 6.2 | 87 |
| | ZI | — | 6.2 | 93 |

| Tipo / Type / Typ | Volume olio Oil volume Ölmenge [l] | | | | Massa Mass Gewicht [kg] |
|-------------------|--|----------------------|----------------------|----------------|----------------------------------|
| | Posizione / Position / Position | | | | |
| | B0 | F0 F1 F2 F3 | H0 H1 H2 H3 | B1 B2 B3 | |

| | | | | |
|--------|-----|-----|-----|------|
| RA310 | M.. | 3.6 | 1.8 | 46.5 |
| | S.. | 4.5 | 2.2 | 57.6 |
| | FS | 2.9 | 1.5 | 40 |
| RA310D | M.. | 3.9 | 1.9 | 52 |
| | S.. | 4.8 | 2.4 | 61 |
| | FS | 3.2 | 1.6 | 42.5 |
| RA310T | M.. | 3.6 | 1.8 | 56 |
| | S.. | 4.5 | 2.2 | 65 |
| | FS | 2.9 | 1.4 | 45 |
| RA510 | M.. | 6.5 | 3.3 | 81 |
| | S.. | 7.4 | 3.7 | 92 |
| | FS | 5.8 | 2.9 | 70 |
| RA510D | M.. | 4.2 | 2.1 | 59 |
| | S.. | 5.2 | 2.6 | 77 |
| | FS | 3.6 | 1.8 | 55 |
| RA510T | M.. | 4.5 | 2.3 | 62 |
| | S.. | 5.4 | 2.7 | 78 |
| | FS | 3.9 | 1.9 | 57 |
| RA710 | M.. | 6.5 | 3.2 | 74 |
| | S.. | 7.3 | 3.6 | 92 |
| | FS | 5.8 | 2.9 | 72 |
| RA710D | M.. | 4.2 | 2.1 | 77 |
| | S.. | 5 | 2.5 | 73 |
| | FS | 3.5 | 1.8 | 52 |
| RA710T | M.. | 4.5 | 2.3 | 78 |
| | S.. | 5.3 | 2.6 | 85 |
| | FS | 3.8 | 1.9 | 57 |
| RA810 | M.. | 8.5 | 4.3 | 111 |
| | S.. | 8.7 | 4.3 | 117 |
| | FS | 7.5 | 3.8 | 82 |
| RA810D | M.. | 5.5 | 2.8 | 74 |
| | S.. | 5.7 | 2.9 | 98 |
| | FS | 4.6 | 2.3 | 57 |
| RA810T | M.. | 5.8 | 2.9 | 77 |
| | S.. | 6 | 3.0 | 103 |
| | FS | 4.8 | 2.4 | 90 |

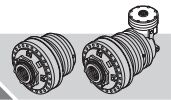

| Type / Tipo / Tipo | Volume huile Volumen aceite Volume óleo [l] | | | Masse Masa Massa [kg] |
|--------------------|---|---|---|--------------------------------|
| | Position / Posición / Posição | | | |
| | A | E | G | |

| | | | | |
|--------|-----|-----|-----|------|
| RR310 | M.. | 1.1 | 2.1 | 21 |
| | S.. | 1.5 | 3.0 | 43 |
| | FS | 0.7 | 1.5 | 20 |
| RR310D | M.. | 1.2 | 2.4 | 36 |
| | S.. | 1.7 | 3.3 | 47 |
| | FS | 0.9 | 1.8 | 23 |
| RR310T | M.. | 1.1 | 2.1 | 38 |
| | S.. | 1.5 | 3.0 | 49 |
| | FS | 0.7 | 1.5 | 26.5 |
| RR310Q | M.. | 1.1 | 2.1 | 41 |
| | S.. | 1.5 | 3.0 | 53 |
| | FS | 0.7 | 1.5 | 29.5 |
| RR510 | M.. | 0.9 | 1.8 | 35 |
| | S.. | 1.4 | 2.7 | 44 |
| | FS | 0.6 | 1.2 | 28 |
| RR510D | M.. | 1.4 | 2.8 | 52 |
| | S.. | 1.9 | 3.7 | 60 |
| | FS | 1.1 | 2.1 | 37 |
| | VI | — | 2.5 | 51 |
| RR510T | M.. | 1.5 | 3.1 | 55 |
| | S.. | 2 | 4.0 | 61 |
| | FS | 1.2 | 2.4 | 39 |
| | VI | — | 2.8 | 54 |
| RR510Q | M.. | 1.4 | 2.8 | 59 |
| | S.. | 1.9 | 3.7 | 65 |
| | FS | 1.1 | 2.1 | 49 |
| | VI | — | 2.5 | 58 |
| RR710 | M.. | 0.9 | 1.8 | 34 |
| | S.. | 1.3 | 2.6 | 48 |
| | FS | 0.6 | 1.1 | 23 |
| RR710D | M.. | 1.4 | 2.8 | 54 |
| | S.. | 1.8 | 3.6 | 62 |
| | FS | 1 | 2.1 | 37 |
| | VI | — | 2.6 | 50 |
| RR710T | M.. | 1.5 | 3.1 | 56 |
| | S.. | 1.9 | 3.8 | 67 |
| | FS | 1.2 | 2.4 | 39 |
| | VI | — | 2.9 | 52 |
| RR710Q | M.. | 1.4 | 2.8 | 64 |
| | S.. | 1.8 | 3.5 | 75 |
| | FS | 1 | 2.1 | 47 |
| | VI | - | 2.6 | 60 |
| RR810 | M.. | 1.9 | 3.8 | 64 |
| | S.. | 2 | 4.0 | 70 |
| | FS | 1.4 | 2.8 | 41 |
| RR810D | M.. | 2.1 | 4.1 | 77 |
| | S.. | 2.1 | 4.3 | 81 |
| | FS | 1.6 | 3.1 | 61 |
| | VI | — | 5.9 | 81 |
| | ZI | — | 5.9 | 87 |
| RR810T | M.. | 2.2 | 4.4 | 83 |
| | S.. | 2.3 | 4.5 | 86 |
| | FS | 1.7 | 3.4 | 63 |
| | VI | — | 6.2 | 87 |
| | ZI | — | 6.2 | 93 |

| Type / Tipo / Tipo | Volume huile Volumen aceite Volume óleo [l] | | | | Masse Masa Massa [kg] |
|--------------------|---|----------------------|----------------------|----------------|--------------------------------|
| | Position / Posición / Posição | | | | |
| | B0 | F0 F1 F2 F3 | H0 H1 H2 H3 | B1 B2 B3 | |

| | | | | |
|--------|-----|-----|-----|------|
| RA310 | M.. | 3.6 | 1.8 | 46.5 |
| | S.. | 4.5 | 2.2 | 57.6 |
| | FS | 2.9 | 1.5 | 40 |
| RA310D | M.. | 3.9 | 1.9 | 52 |
| | S.. | 4.8 | 2.4 | 61 |
| | FS | 3.2 | 1.6 | 42.5 |
| RA310T | M.. | 3.6 | 1.8 | 56 |
| | S.. | 4.5 | 2.2 | 65 |
| | FS | 2.9 | 1.4 | 45 |
| RA510 | M.. | 6.5 | 3.3 | 81 |
| | S.. | 7.4 | 3.7 | 92 |
| | FS | 5.8 | 2.9 | 70 |
| RA510D | M.. | 4.2 | 2.1 | 59 |
| | S.. | 5.2 | 2.6 | 77 |
| | FS | 3.6 | 1.8 | 55 |
| RA510T | M.. | 4.5 | 2.3 | 62 |
| | S.. | 5.4 | 2.7 | 78 |
| | FS | 3.9 | 1.9 | 57 |
| RA710 | M.. | 6.5 | 3.2 | 74 |
| | S.. | 7.3 | 3.6 | 92 |
| | FS | 5.8 | 2.9 | 72 |
| RA710D | M.. | 4.2 | 2.1 | 77 |
| | S.. | 5 | 2.5 | 73 |
| | FS | 3.5 | 1.8 | 52 |
| RA710T | M.. | 4.5 | 2.3 | 78 |
| | S.. | 5.3 | 2.6 | 85 |
| | FS | 3.8 | 1.9 | 57 |
| RA810 | M.. | 8.5 | 4.3 | 111 |
| | S.. | 8.7 | 4.3 | 117 |
| | FS | 7.5 | 3.8 | 82 |
| RA810D | M.. | 5.5 | 2.8 | 74 |
| | S.. | 5.7 | 2.9 | 98 |
| | FS | 4.6 | 2.3 | 57 |
| RA810T | M.. | 5.8 | 2.9 | 77 |
| | S.. | 6.0 | 3 | 103 |
| | FS | 4.8 | 2.4 | 90 |

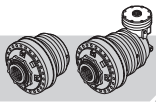

| Tipo / Type / Typ | Volume olio Oil volume Ölmenge [l] | | | Massa Mass Gewicht [kg] |
|-------------------|--|---|---|----------------------------------|
| | Posizione / Position / Position | | | |
| | A | E | G | |

| | | | | |
|---------|-----|-----|------|-----|
| RR810Q | M.. | 2.0 | 4.1 | 87 |
| | S.. | 2.1 | 4.2 | 94 |
| | FS | 1.6 | 3.1 | 66 |
| | VI | — | 5.9 | 91 |
| | ZI | — | 5.9 | 97 |
| RR1010 | M.. | 2.7 | 5.4 | 82 |
| | FS | 1.7 | 3.5 | 53 |
| RR1010D | M.. | 2.7 | 5.4 | 100 |
| | FS | 1.7 | 3.5 | 77 |
| | VI | — | 9.2 | 108 |
| | ZI | — | 9.2 | 122 |
| RR1010T | M.. | 3.2 | 6.3 | 121 |
| | FS | 2.2 | 4.4 | 99 |
| | VI | — | 10.2 | 129 |
| | ZI | — | 10.2 | 143 |
| RR1010Q | M.. | 3.3 | 6.6 | 124 |
| | FS | 2.4 | 4.7 | 102 |
| | VI | — | 10.5 | 132 |
| | ZI | — | 10.5 | 146 |
| RR1700 | B.. | 2.8 | 5.7 | 112 |
| | M.. | 3.2 | 6.5 | 88 |
| | FS | 1.9 | 3.8 | 70 |
| RR1700D | B.. | 2.8 | 5.7 | 136 |
| | M.. | 3.2 | 6.4 | 105 |
| | FS | 1.9 | 3.8 | 89 |
| | VI | — | 9.5 | 125 |
| | ZI | — | 9.5 | 137 |
| RR1700T | B.. | 3.3 | 6.6 | 147 |
| | M.. | 3.7 | 7.4 | 120 |
| | FS | 2.4 | 4.8 | 105 |
| | VI | — | 10.5 | 140 |
| | ZI | — | 10.5 | 152 |
| RR1700Q | B.. | 3.5 | 6.9 | 148 |
| | M.. | 3.8 | 7.7 | 131 |
| | FS | 2.5 | 5.1 | 106 |
| | VI | — | 10.8 | 141 |
| | ZI | — | 10.8 | 153 |

| Tipo / Type / Typ | Volume olio Oil volume Ölmenge [l] | | | | Massa Mass Gewicht [kg] |
|-------------------|--|----------------------|----------------------|----------------|----------------------------------|
| | Posizione / Position / Position | | | | |
| | B0 | F0 F1 F2 F3 | H0 H1 H2 H3 | B1 B2 B3 | |

| | | | | |
|------------|---------|------|-----|-----|
| RA1010 (A) | M.. | 10.1 | 5.0 | 124 |
| | FS | 8.1 | 4.1 | 90 |
| RA1010 (B) | M.. | 13.8 | 6.9 | 161 |
| | FS | 11.9 | 5.9 | 133 |
| RA1010D | M.. | 10.0 | 5.0 | 143 |
| | FS | 8.1 | 4.1 | 109 |
| RA1010T | M.. | 7.8 | 3.9 | 148 |
| | FS | 5.9 | 2.9 | 94 |
| RA1700 (A) | B.. | 10.4 | 5.2 | 227 |
| | M.. | 11.1 | 5.6 | 160 |
| | FS | 8.5 | 4.2 | 100 |
| RA1700 (B) | B.. | 14.1 | 7.0 | 177 |
| | M.. | 14.9 | 7.4 | 171 |
| | FS | 12.2 | 6.1 | 144 |
| RA1700D | B.. | 10.3 | 5.2 | 179 |
| | M.. | 11.1 | 5.6 | 179 |
| | FS | 8.5 | 4.2 | 119 |
| | RA1700T | B.. | 8.1 | 4.0 |
| M.. | | 8.8 | 4.4 | 157 |
| FS | | 6.2 | 3.1 | 104 |

6.6 Sistemi ausiliari di raffreddamento

Quando la potenza da trasmettere è superiore alla potenza termica che il riduttore è in grado di smaltire, è necessario impiegare un sistema ausiliario di raffreddamento che, oltre a permettere lo smaltimento della potenza termica in eccesso P_S , consente di effettuare la filtrazione del lubrificante, prolungando la vita di ingranaggi e cuscinetti.

Sono disponibili, a richiesta, tre tipi di sistemi ausiliari di raffreddamento, le cui caratteristiche e dimensioni sono indicate di seguito.

6.6 Auxiliary cooling systems

When the power to be transmitted is higher than the thermal power the reduction gear is able to get rid of, you will have to use an auxiliary cooling system which, besides getting rid of the thermal power in excess P_S , also allows the lubricant to be filtered which prolongs the life of both gears and bearings.

On request three types of auxiliary cooling systems are available. Their specifications and dimensions are given in the following table.

6.6 Zusätzliche Kühlsysteme

Wenn die Leistung, die übertragen wird, die Wärmeleistung übersteigt, die das Planetengetriebe ableiten kann, muss ein zusätzliches Kühlsystem installiert werden, das nicht nur eine Ableitung der überschüssigen Wärmeleistung P_S erlaubt, sondern auch ein Filtern vom Schmieröl möglich macht und damit die Lebensdauer der Zahnräder und Lager erhöht.

Auf Wunsch sind drei verschiedene Kühlsysteme erhältlich (siehe Tabelle unten).

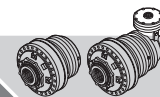

| Type / Tipo / Tipo | Volumen aceite Volume óleo [l] | | | Masse Masa Massa [kg] |
|--------------------|-----------------------------------|---|---|--------------------------------|
| | Position / Posición / Posição | | | |
| | A | E | G | |

| | | | | |
|---------|-----|-----|------|-----|
| RR810Q | M.. | 2.0 | 4.1 | 87 |
| | S.. | 2.1 | 4.2 | 94 |
| | FS | 1.6 | 3.1 | 66 |
| | VI | — | 5.9 | 91 |
| | ZI | — | 5.9 | 97 |
| RR1010 | M.. | 2.7 | 5.4 | 82 |
| | FS | 1.7 | 3.5 | 53 |
| RR1010D | M.. | 2.7 | 5.4 | 100 |
| | FS | 1.7 | 3.5 | 77 |
| | VI | — | 9.2 | 108 |
| | ZI | — | 9.2 | 122 |
| RR1010T | M.. | 3.2 | 6.3 | 121 |
| | FS | 2.2 | 4.4 | 99 |
| | VI | — | 10.2 | 129 |
| | ZI | — | 10.2 | 143 |
| RR1010Q | M.. | 3.3 | 6.6 | 124 |
| | FS | 2.4 | 4.7 | 102 |
| | VI | — | 10.5 | 132 |
| | ZI | — | 10.5 | 146 |
| RR1700 | B.. | 2.8 | 5.7 | 112 |
| | M.. | 3.2 | 6.5 | 88 |
| | FS | 1.9 | 3.8 | 70 |
| RR1700D | B.. | 2.8 | 5.7 | 136 |
| | M.. | 3.2 | 6.4 | 105 |
| | FS | 1.9 | 3.8 | 89 |
| | VI | — | 9.5 | 125 |
| | ZI | — | 9.5 | 137 |
| RR1700T | B.. | 3.3 | 6.6 | 147 |
| | M.. | 3.7 | 7.4 | 120 |
| | FS | 2.4 | 4.8 | 105 |
| | VI | — | 10.5 | 140 |
| | ZI | — | 10.5 | 152 |
| RR1700Q | B.. | 3.5 | 6.9 | 148 |
| | M.. | 3.8 | 7.7 | 131 |
| | FS | 2.5 | 5.1 | 106 |
| | VI | — | 10.8 | 141 |
| | ZI | — | 10.8 | 153 |

| Type / Tipo / Tipo | Volumen aceite Volume óleo [l] | | | | Masse Masa Massa [kg] |
|--------------------|-----------------------------------|----------------------|----------------------|----------------|--------------------------------|
| | Position / Posición / Posição | | | | |
| | B0 | F0 F1 F2 F3 | H0 H1 H2 H3 | B1 B2 B3 | |

| | | | | |
|------------|---------|------|-----|-----|
| RA1010 (A) | M.. | 10.1 | 5.0 | 124 |
| | FS | 8.1 | 4.1 | 90 |
| RA1010 (B) | M.. | 13.8 | 6.9 | 161 |
| | FS | 11.9 | 5.9 | 133 |
| RA1010D | M.. | 10.0 | 5.0 | 143 |
| | FS | 8.1 | 4.1 | 109 |
| RA1010T | M.. | 7.8 | 3.9 | 148 |
| | FS | 5.9 | 2.9 | 94 |
| RA1700 (A) | B.. | 10.4 | 5.2 | 227 |
| | M.. | 11.1 | 5.6 | 160 |
| | FS | 8.5 | 4.2 | 100 |
| RA1700 (B) | B.. | 14.1 | 7.0 | 177 |
| | M.. | 14.9 | 7.4 | 171 |
| | FS | 12.2 | 6.1 | 144 |
| RA1700D | B.. | 10.3 | 5.2 | 179 |
| | M.. | 11.1 | 5.6 | 179 |
| | FS | 8.5 | 4.2 | 119 |
| | RA1700T | B.. | 8.1 | 4.0 |
| M.. | | 8.8 | 4.4 | 157 |
| FS | | 6.2 | 3.1 | 104 |

6.6 Systèmes auxiliaires de refroidissement

Quand la puissance à transmettre est supérieure à la puissance thermique que le réducteur est en mesure d'évacuer, il faut utiliser un système auxiliaire de refroidissement qui non seulement permet d'évacuer la puissance thermique en excès P_S , mais permet aussi de filtrer la graisse, et par conséquent de prolonger la vie des engrenages et des roulements.

Il existe, en option, trois types de systèmes auxiliaires de refroidissement dont les caractéristiques et les dimensions sont indiquées ci-dessous.

6.6 Sistemas auxiliares de refrigeración

Quando la potencia a transmitir es mayor que la potencia térmica que el reductor es capaz de eliminar, es necesario utilizar un sistema auxiliar de refrigeración que, además de permitir la eliminación de la potencia térmica en exceso P_S , permite efectuar el filtrado del lubricante, alargando la vida de engranajes y cojinetes.

Hay disponibles, bajo pedido, tres tipos de sistemas auxiliares de refrigeración, cuyas características y medidas se indican a continuación.

6.6 Sistemas auxiliares de arrefecimento

Quando a potência a transmitir é superior à potência térmica que o reductor é capaz de eliminar, é necessário usar um sistema auxiliar de arrefecimento que, além de consentir a eliminação da potência térmica em excesso P_S , consente efetuar a filtragem do lubrificante, prolongando a vida das engrenagens e dos rolamentos.

A pedido é possível obter três tipos de sistemas auxiliares de arrefecimento, cujas características e dimensões estão indicadas a seguir.

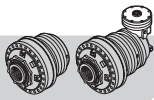

| | | CSU 04 | CSU 10 | CSU 20 |
|--|---------------------|----------|----------|----------|
| Portata olio <i>Oil flow rate</i> Öldurchsatz | [l/min] | 10 | 10 | 23 |
| * Potenza termica dissipata <i>* Thermal power dissipated</i> * abgeleitete Wärmeleistung (per/where /für $\Delta t = t_r - T_a = 40^\circ\text{C}$) | [kW] | 4 | 10 | 20 |
| Portata aria <i>Air flow rate</i> Luftdurchsatz | [m ³ /h] | 700 | 4080 | 4500 |
| Potenza assorbita <i>Power consumption</i> Leistungsaufnahme | [kW] | 0.5 | 0.75 | 1.1 |
| Pressione massima <i>Maximum pressure</i> Höchstdruck | [bar] | 6 | 6 | 6 |
| Runorosità a 1 metro <i>Noise at 1 metre</i> Lärmpegel im Abstand von 1 Meter | [dB(A)] | - | - | - |
| Peso <i>Weight</i> Gewicht | [kg] | - | - | - |
| Tensione di alimentazione <i>Power voltage</i> Versorgungsspannung | [V] | 230/400 | 230/400 | 230/400 |
| Frequenza di alimentazione <i>Power frequency</i> Versorgungsfrequenz | [Hz] | 50/60 | 50/60 | 50/60 |
| Indice di protezione <i>Protection level</i> Schutzart | IP | 55 | 55 | 55 |
| Codice Reggiana Riduttori <i>Reggiana Riduttori Code</i> Code von Reggiana Riduttori | [-] | 154F7016 | 154F7017 | 154F7018 |

* Potenza dissipata dallo scambiatore con olio con viscosità: ISO VG 150 a 0 metri s.l.m.

* *Power dissipated by the exchanger with oil viscosity: ISO VG 150 at 0 metres above sea level.*

* Vom Wärmeaustauscher abgeleitete Leistung mit Öl mit einer Viskosität von ISO VG 150 bei 0 m ü. NN.

| | A | B | C | D | E | F | ØH | L | M |
|---------------|-----|-----|-------|-----|-----|----|----|-------|---------|
| CSU 04 | 465 | 537 | 418.5 | 347 | 280 | 20 | 9 | 179.5 | 273.5±3 |
| CSU 10 | 682 | 549 | 616.5 | 555 | 300 | 20 | 9 | 278.5 | 471.5±3 |
| CSU 20 | 830 | 657 | 755 | 695 | 380 | 20 | 9 | 305 | 570.5±3 |

D,E,F,H: quote relative ai 4 fori previsti per il fissaggio
D,E,F,H: dimensions for the 4 fixing holes
 D,E,F,H: Abmessungen bezogen auf die 4 Befestigungslöcher

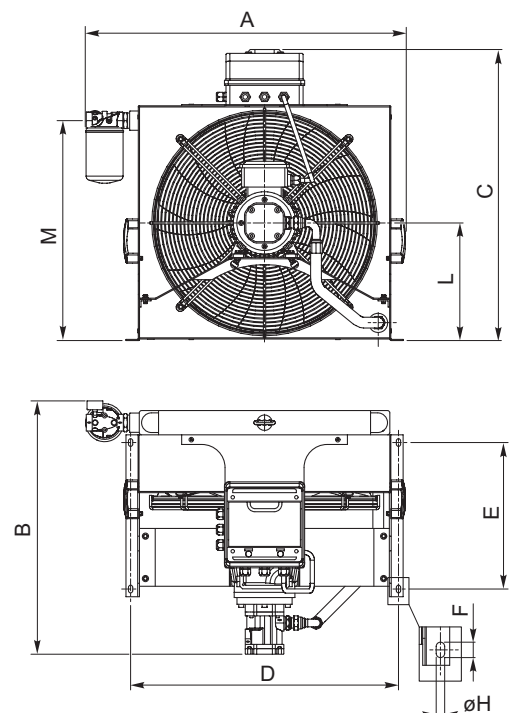

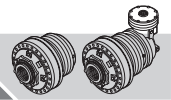

| | | CSU 04 | CSU 10 | CSU 20 |
|--|---------------------|----------|----------|----------|
| Débit huile Caudal aceite Caudal óleo | [l/min] | 10 | 10 | 23 |
| * Puissance thermique dissipée * Potencia térmica disipada * Potência térmica dissipada (pour/para/para $\Delta t = t_r - T_a = 40^\circ\text{C}$) | [kW] | 4 | 10 | 20 |
| Débit d'air Caudal aire Caudal ar | [m ³ /h] | 700 | 4080 | 4500 |
| Puissance absorbée Potencia absorbida Potência consumida | [kW] | 0.5 | 0.75 | 1.1 |
| Pression maximum Presión máxima Pressão máxima | [bar] | 6 | 6 | 6 |
| Nuisances sonores à 1 mètre Ruido a 1 metro Rumor a 1 metro | [dB(A)] | - | - | - |
| Poids Peso Peso | [kg] | - | - | - |
| Tension d'alimentation Tensión de alimentación Tensão de alimentação | [V] | 230/400 | 230/400 | 230/400 |
| Fréquence d'alimentation Frecuencia de alimentación Frequência de alimentação | [Hz] | 50/60 | 50/60 | 50/60 |
| Indice de protection Índice de protección Índice de proteção | IP | 55 | 55 | 55 |
| Code Reggiana Riduttori Código Reggiana Riduttori Código Reggiana Riduttori | [-] | 154F7016 | 154F7017 | 154F7018 |

* Puissance dissipée par l'échangeur avec une huile à viscosité: ISO VG 150 à 0 mètres au-dessus du niveau de la mer.

* Potencia disipada por el intercambiador con aceite con viscosidad: ISO VG 150 a 0 metros s.n.m.

* Potência dissipada pelo permutador com óleo com viscosidade: ISO VG 150 a 0 metros s.n.m.

| | A | B | C | D | E | F | ØH | L | M |
|---------------|-----|-----|-------|-----|-----|----|----|-------|---------|
| CSU 04 | 465 | 537 | 418.5 | 347 | 280 | 20 | 9 | 179.5 | 273.5±3 |
| CSU 10 | 682 | 549 | 616.5 | 555 | 300 | 20 | 9 | 278.5 | 471.5±3 |
| CSU 20 | 830 | 657 | 755 | 695 | 380 | 20 | 9 | 305 | 570.5±3 |

D,E,F,H: quote relative ai 4 fori previsti per il fissaggio
D,E,F,H: dimensions for the 4 fixing holes
D,E,F,H: Abmessungen bezogen auf die 4 Befestigungslöchern

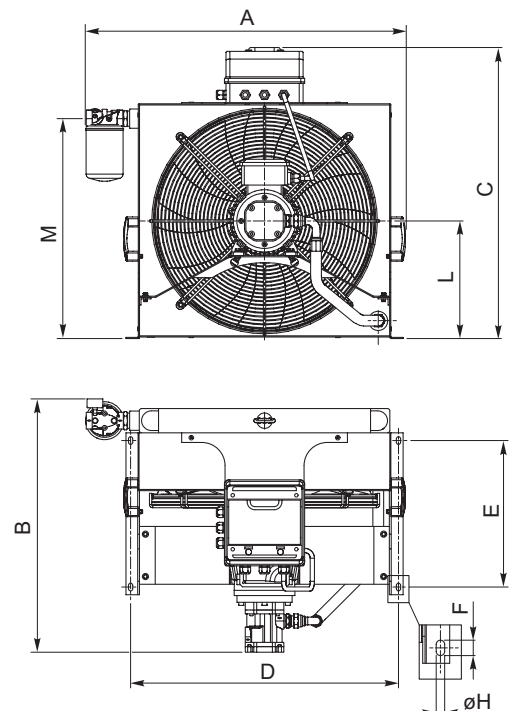

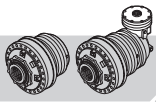

Componenti fondamentali del sistema ausiliario di raffreddamento sono: uno scambiatore di calore olio-aria, una pompa ad ingranaggi (a cilindrata fissa), un motore elettrico, un filtro spin-on (grado di filtrazione 60 μm), un ventilatore coassiale alla pompa e due termostati da installare sul riduttore, uno tarato per la temperatura minima di avviamento del sistema, che inibisce la partenza dell'unità di raffreddamento fino alla temperatura di 60°C e l'altro tarato per una temperatura massima, superata la quale si può azionare un allarme e/o interrompere il funzionamento del riduttore e un manometro per visualizzare la pressione di mandata.

Inoltre per le posizioni di montaggio con asse verticale e comunque in tutti quei casi in cui si adotta il completo riempimento di lubrificante, è necessario montare un vaso di espansione.

Si consiglia, in questi casi, di impiegare il vaso di espansione BA 200.

A richiesta possono essere forniti dei componenti opzionali quali:

- flussimetro per consentire un'indicazione visiva del passaggio di olio;
- pressostato per segnalare, tramite commutazione di contatto elettrico, sovrappressioni all'interno del riduttore;
- centralina con regolazione continua della temperatura mediante valvola di bypass;
- filtro con differente grado di filtrazione (10, 25, 90 o 125 μm);
- termostato con differente temperatura di avviamento (50°C o 40°C)

Il collegamento dei contatti elettrici e del circuito idraulico e tutto il materiale occorrente allo scopo sono a carico del cliente.

La scelta del sistema più idoneo, va fatta in base alla potenza termica P_S che è necessario dissipare e alla differenza Δt tra la temperatura dell'olio all'interno del riduttore t_R e la temperatura ambiente t_a , con l'aiusilio del seguente grafico.

Fundamental components of the auxiliary cooling system are: an oil-air heat exchanger, a gear pump (constant displacement type), an electric motor, a spin-on filter (with a filtering degree of 60 μm), a fan coaxial with the pump and two thermostats to install on the reduction gear, one set for the minimum system start-up temperature, which prevents the cooling unit starting until a temperature of 60°C is reached, and the other set for a maximum temperature which, when exceeded, can trigger an alarm and/or stop the reduction gear working and a gauge to see delivery pressure.

In addition, for the assembly positions with a vertical axis and, of course, whenever the reduction gear is filled up completely with lubricant, an expansion tank has to be mounted.

In these cases we recommend using the BA 200 expansion tank.

On request optional components can be supplied, such as:

- *a flow meter so as to have a visual of the oil's passage;*
- *a pressure switch to indicate overpressures inside the reduction gear by the switching of an electrical contact;*
- *control unit with continuous adjustment of the temperature by means of a bypass valve;*
- *filter with a different filtering degree (10, 25, 90 or 125 μm);*
- *Thermostat with different start-up temperature (either 50°C or 40°C)*

Connection of the electrical contacts and hydraulic circuit and all the material needed for it are the responsibility of the customer.

The choice of the most suitable system must be made based on the thermal power P_S you need to dissipate and on the Δt difference between the temperature of the oil inside the reduction gear t_R and ambient temperature t_a , using this graph to help you.

Das zusätzliche Kühlsystem umfasst folgende Komponenten: ein Öl-Luft-Wärmeaustauscher, eine Zahnradpumpe (mit vorgegebene Hubraum), ein Elektromotor, ein Spin-on Filter (Filterstärke 60 μm), ein koaxiales Gebläse zur Pumpe und zwei Thermostate, die am Planetengetriebe installiert werden. Ein Thermostat wird auf die Mindesttemperatur zum Starten vom Kühlsystem geeicht und verhindert das Einschalten vom Kühlsystem bis zu einer Temperatur von 60°C, der andere Thermostat wird auf die Höchsttemperatur geeicht, bei deren Überschreiten ein Alarm ausgelöst u/o das Planetengetriebe abgeschaltet werden kann und eine Manometer zu Anzeige vom Druck am Eingang.

Bei Montage in Position mit vertikaler Achse und immer dann, wenn mit voller Ölfüllung gearbeitet wird, muss außerdem ein Ausdehnungsgefäß installiert werden.

In diesen Fällen wird dazu geraten, das Ausdehnungsgefäß BA 200 zu installieren.

Auf Wunsch ist folgendes Zubehör erhältlich:

- Durchflussmesser mit Sichtglas für Ölfluss;
- Druckwächter zur Anzeige vom Überdruck im Planetengetriebe durch Umschalten eines elektrischen Kontakts;
- Steuergerät für stufenlose Temperaturregelung mittels Bypass-Ventil;
- Filter mit anderer Filterstärke (10, 25, 90 oder 125 μm);
- Thermostat mit unterschiedlicher Starttemperatur (50°C oder 40°C)

Für den Anschluss der elektrischen Kontakte und vom Ölkreislauf sowie die Bereitstellung des erforderlichen Materials ist der Kunde zuständig.

Das geeignete System wird anhand der Wärmeleistung P_S ausgewählt, die abgeleitet werden muss, und der Differenz Δt zwischen der Öltemperatur im Planetengetriebe t_R und der Umgebungstemperatur t_a , und zwar mit folgender Grafik:

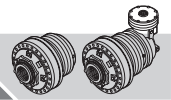

Les composants fondamentaux du système auxiliaire de refroidissement sont: un échangeur de chaleur huile-air, une pompe à engrenages (à cylindrée fixe), un moteur électrique, un filtre spin-on (degré de filtration 60 μm), un rotor de ventilation coaxial à la pompe et deux thermostats à installer sur le réducteur, l'un taré pour la température minimum de démarrage du système, qui inhibe le démarrage de l'unité de refroidissement jusqu'à la température de 60°C et l'autre, taré pour une température maximum, au-delà de laquelle on peut déclencher une alarme et/ou interrompre le fonctionnement du réducteur, et un manomètre pour visualiser la pression de refoulement

De plus, pour les positions de montage avec axe vertical et de toute façon dans tous les cas où on adopte le nourrissage complet de lubrifiant, il est nécessaire de monter un vase d'expansion.

Il est conseillé, dans ces cas-là, d'utiliser le vase d'expansion BA 200.

Il existe, en option, des composants tels que:

- le fluxmètre, pour permettre une indication visuelle du passage de l'huile;
- le pressostat pour signaler, par commutation de contact électrique, toute surpression dans le réducteur;
- centrale avec réglage continu de la température par l'intermédiaire d'une vanne de dérivation;
- le filtre avec un degré de filtration (10, 25, 90 ou 125 μm);
- thermostat avec différente température de démarrage (50°C ou 40°C)

Le branchement des contacts électriques et du circuit hydraulique et tout le matériel utile sont à la charge du client.

Le choix du système le plus approprié doit être fait en fonction de la puissance thermique P_S nécessaire à dissiper et à la différence Δt entre la température de l'huile dans le réducteur t_R et la température ambiante t_a , à l'aide du graphique ci-dessous.

Los componentes fundamentales del sistema auxiliar de refrigeración son: un intercambiador de calor aceite-aire, una bomba de engranajes (de cilindrada fija), un motor eléctrico, un filtro spin-on (grado de filtración 60 μm), un ventilador coaxial respecto a la bomba y dos termostatos a instalar en el reductor, uno calibrado para la temperatura mínima de arranque del sistema, que impide el arranque de la unidad de refrigeración hasta la temperatura de 60°C y el otro calibrado para una temperatura máxima, superada la cual se puede activar una alarma y/o interrumpir el funcionamiento del reductor y un manómetro para visualizar la presión de impulsión.

Además, para las posiciones de montaje con eje vertical y de todas maneras en todos los casos en que se efectúa el llenado completo de lubricante, es necesario montar un vaso de expansión.

Se aconseja, en estos casos, utilizar el vaso de expansión BA 200.

Bajo pedido se pueden proporcionar unos componentes opcionales como:

- *medidor de flujo para consentir una indicación visual del paso de aceite;*
- *presostato para señalar, trámite conmutación de contacto eléctrico, sobrepresiones dentro del reductor;*
- *centralita con regulación continua de la temperatura por medio de válvula de bypass;*
- *filtro con distinto grado de filtración (10, 25, 90 ó 125 μm);*
- *termostato con diferente temperatura de arranque (50°C ó 40°C)*

El conexionado de los contactos eléctricos y del circuito hidráulico y todo el material necesario para ello son a cargo del cliente.

La selección del sistema más idóneo debe ser efectuada sobre la base de la potencia térmica P_S que es necesario disipar y de la diferencia Δt entre la temperatura del aceite dentro del reductor t_R y la temperatura ambiente t_a , con el auxilio del siguiente gráfico.

Os componentes fundamentais do sistema auxiliar de arrefecimento são: um permutador de calor óleo-ar, uma bomba de engrenagens (com cilindrada fixa), um motor elétrico, um filtro spin-on (grau de filtragem 60 μm), um ventilador coaxial à bomba e dois termostatos a instalar no reductor, um regulado para a temperatura mínima de início de trabalho do sistema, que inibe a partida da unidade de arrefecimento até à temperatura de 60°C e o outro regulado para uma temperatura máxima, superada a qual se pode accionar um alarme e/ou interromper o funcionamento do reductor e um manómetro para visualizar a pressão de ida.

Além disso, para as posições de montagem com eixo vertical e em todos aqueles casos em que se adota o completo enchimento de lubrificante, é necessário montar um depósito de expansão.

Aconselhamos, nestes casos, usar o depósito de expansão BA 200.

A pedido, podem ser fornecidos os componentes opcionais como:

- fluxímetro para consentir uma indicação visual da passagem do óleo;
- pressostato para assinalar, através de comutação de contato elétrico, sobrepensões no interior do reductor;
- Central com regulação contínua da temperatura mediante válvula de bypass;
- filtro com diferente grau de filtragem (10, 25, 90 ou 125 μm);
- Termostato com temperatura de arranque diferente (50°C ou 40°C).

A ligação dos contatos elétricos e do circuito hidráulico assim como todo o material necessário para este fim, são a cargo do cliente.

A escolha do sistema mais idóneo, é feita segundo a potência térmica P_S que é necessário dissipar e à diferença Δt entre a temperatura do óleo no interior do reductor t_R e a temperatura ambiente t_a , com a ajuda do seguinte gráfico.

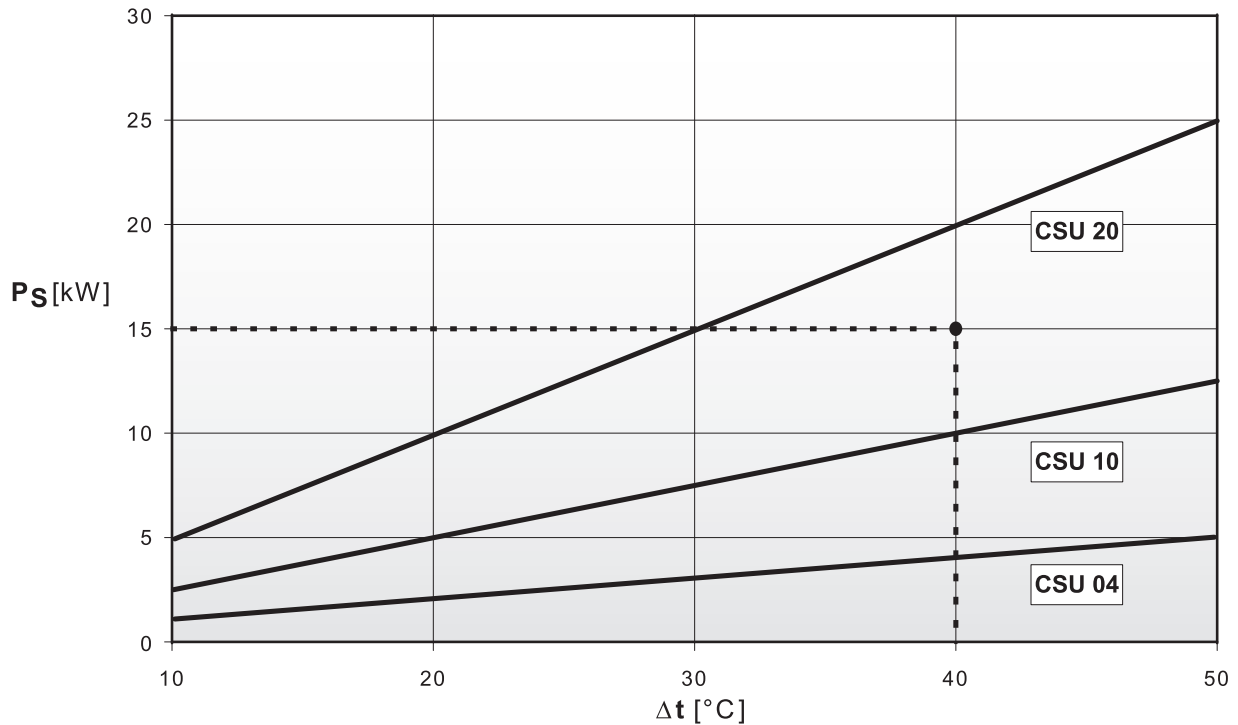
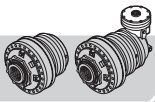

Esempio

Si deve dimensionare un sistema ausiliario di raffreddamento per smaltire una potenza termica $P_S = 15$ kW da un riduttore che lavora alla temperatura di esercizio di 60°C , con temperatura ambiente di 20°C .

Individuando sul grafico il punto di ascissa $\Delta t = 60 - 20 = 40^\circ\text{C}$ ed ordinata $P_S = 15$ kW, questo ricade nella zona indicata con CSU 20. Dunque il sistema idoneo è proprio il CSU 20.

Il collegamento idraulico del sistema ausiliario di raffreddamento va eseguito in modo da aspirare l'olio (ed eventuali detriti) dal punto più in basso (punto (3) nelle figure delle posizioni di montaggio) ed effettuare la mandata da un punto sufficientemente distante dall'aspirazione, in modo da agevolare il ricambio d'olio all'interno del riduttore. Qualora la dimensione del foro di aspirazione fosse insufficiente a smaltire la portata della pompa, occorre prevedere due o più punti di aspirazione, in modo da scongiurare il rischio di cavitazione. Anche per la mandata possono essere impiegati due o più fori di collegamento, ad esempio nel caso di riduttori multistadio.

Example

An auxiliary cooling system has to be sized to get rid of a thermal power of $P_S = 15$ kW from a reduction gear working at an operating temperature of 60°C with an ambient temperature of 20°C .

Finding the abscissa $\Delta t = 60 - 20 = 40^\circ\text{C}$ and ordinate $P_S = 15$ kW, point on the graph, it comes in the area marked with CSU 20. This means that the suitable system is, in fact, the CSU 20.

The hydraulic connection of the auxiliary cooling system must be done so as to intake the oil (and any detritus) from the lowest point (point (3) in the assembly positions figures) and have the delivery from a point far enough away from the intake to facilitate changing the oil from inside the reduction gear. If the intake hole is not big enough to get rid of the pump's flow, two or more intake points must be foreseen to guarantee against the risk of cavitation. Two or more connection holes may also be used for delivery, for example, in the case of multi-stage reduction gears.

Beispiel

Ein zusätzliches Kühlsystem soll darauf ausgelegt werden, eine Wärmeleistung von $P_S = 15$ kW von einem Planetengetriebe abzuleiten, das mit einer Betriebstemperatur von 60°C und bei einer Umgebungstemperatur von 20°C läuft.

Es wird ein Punkt mit der X-Koordinate $\Delta t = 60 - 20 = 40^\circ\text{C}$ und der Y-Koordinate $P_S = 15$ kW, ermittelt, der im Bereich CSU 20 liegt. Am besten geeignet ist damit das System CSU 20.

Der Hydraulikanschluss vom zusätzlichen Kühlsystem muss so erfolgen, dass das Öl (mit eventuellen Verunreinigungen) an der am weitesten unten liegenden Stelle (Punkt (3) auf den Abbildungen mit der Montageposition) angesaugt und die Druckleitung an einer Stelle angelegt wird, die sich in ausreichender Entfernung von der Ansaugleitung befindet, um den Ölaustausch im Planetengetriebe zu fördern. Sollte die Ansaugöffnung nicht groß genug sein, um den Durchsatz der Pumpe zu bedienen, müssen zwei oder mehr Ansaugstellen vorgesehen werden, um Hohlsockbildung zu vermeiden. Auch für die Druckleitung können zwei oder mehr Anschlüsse vorgesehen werden, zum Beispiel bei mehrstufigen Planetengetrieben.

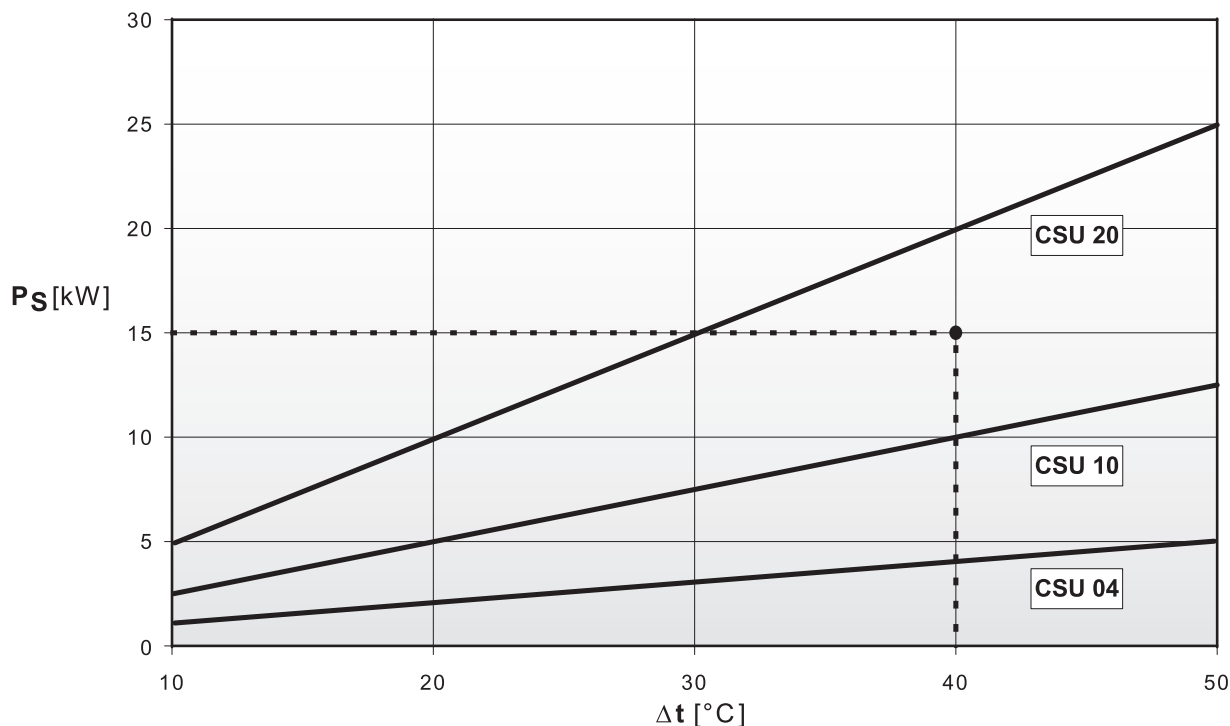
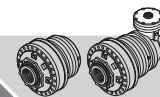

Exemple

Il faut dimensionner un système auxiliaire de refroidissement pour évacuer une puissance thermique $P_S = 15$ kW d'un réducteur qui fonctionne à la température de fonctionnement de 60°C ., à une température ambiante de 20°C .

En prenant sur le graphique le point d'abscisse $\Delta t = 60 - 20 = 40^\circ\text{C}$ et d'ordonnée $P_S = 15$ kW, cela tombe dans la zone indiquée par CSU 20. Le système adéquat est donc bien le CSU 20.

Le raccordement hydraulique du système auxiliaire de refroidissement doit être fait de manière à aspirer l'huile (et tout déchet éventuel) du point le plus bas (indiqué par (3) sur les figures des positions de montage) et effectuer le refoulement d'un point suffisamment distant de l'aspiration, de manière à faciliter le rechange d'huile dans le réducteur. Si la dimension du trou d'aspiration est insuffisante pour évacuer le débit de la pompe, il faut prévoir deux points d'aspiration ou plus, de manière à prévenir le risque de cavitation. Pour le refoulement aussi, il est possible d'utiliser deux trous de raccordement ou plus, par exemple avec des réducteurs multi-étages.

Ejemplo

Se debe dimensionar un sistema auxiliar de refrigeración para eliminar una potencia térmica $P_S = 15$ kW de un reductor que trabaja a la temperatura de funcionamiento de 60°C , con temperatura ambiente de 20°C .

Individuando en el gráfico el punto de abscisa $\Delta t = 60 - 20 = 40^\circ\text{C}$ y ordenada $P_S = 15$ kW, éste queda en la zona indicada con CSU 20. Por lo tanto el sistema idóneo es precisamente el sistema CSU 20.

El conexionado hidráulico del sistema auxiliar de refrigeración se debe realizar de manera que se aspire el aceite (y eventuales detritos) desde el punto más bajo (punto (3) en las figuras de las posiciones de montaje) y efectuar la impulsión desde un punto suficientemente distante de la aspiración, a fin de facilitar el recambio de aceite dentro del reductor. Si las medidas del agujero de aspiración fuesen insuficientes para tratar el caudal de la bomba, es preciso prever dos o más puntos de aspiración, a fin de evitar el riesgo de cavitación. También para la impulsión se pueden utilizar dos o más agujeros de conexión, por ejemplo en el caso de reductores multi-etapa.

Exemplo

Deve-se dimensionar um sistema auxiliar de arrefecimento para eliminar uma potência térmica $P_S = 15$ kW de um reductor que trabalha à temperatura de exercício de 60°C , com temperatura ambiente de 20°C .

Individuando no gráfico o ponto de abscissa $\Delta t = 60 - 20 = 40^\circ\text{C}$ e ordenada $P_S = 15$ kW, o mesmo cai na zona indicada com CSU 20. Portanto o sistema idóneo é mesmo o CSU 20.

A ligação hidráulica do sistema auxiliar de arrefecimento deve ser efetuado de modo a aspirar o óleo (e eventuais detritos) do ponto mais baixo (ponto (3) nas figuras das posições de montagem) e efetuar a ida de um ponto suficientemente distante da aspiração, de modo a facilitar a troca do óleo no interior do reductor. No caso em que a dimensão do furo de aspiração seja insuficiente para tratar o caudal da bomba, é necessário prever dois ou mais pontos de aspiração, de modo da eliminar o perigo de cavitação. Também para o percurso de ida podem ser usados dois ou mais furos de ligação, por exemplo no caso de reductores multi-estádio.

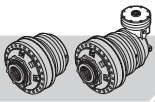

In figura sono riportati alcuni esempi di collegamento del sistema ausiliario di raffreddamento al riduttore, in cui sono mostrati i collegamenti idraulici di aspirazione e mandata e i collegamenti elettrici dei termostati che regolano il funzionamento del sistema.

Il dimensionamento della tubazione di mandata deve tenere conto della distanza tra unità di raffreddamento e riduttore, avendo cura di non superare, nel campo di temperatura di esercizio ($30^{\circ}\text{C} \pm 90^{\circ}\text{C}$), una caduta di pressione complessiva della linea di 2 ± 3 bar.

The figure gives a few examples of connecting the auxiliary cooling system to the reduction gear, where you can see the intake and delivery hydraulic connections as well as the electrical connections of the thermostats that regulate system operation.

The size of the delivery pipes must take into account the distance between the cooling unit and the reduction gear, being careful not to exceed an overall line pressure drop of 2 ± 3 bar in the operating temperature range ($30^{\circ}\text{C} \pm 90^{\circ}\text{C}$).

Die Abbildung zeigt einige Anschlussbeispiele vom Kühlsystem an das Planetengetriebe mit Angabe der Hydraulikanlüsse von Saug- und Druckleitung und der elektrischen Anschlüsse der Thermostate, die den Betrieb vom Kühlsystem regeln.

Die Auslegung der Druckleitung muss den Abstand zwischen Kühlsystem und Planetengetriebe berücksichtigen. Dabei muss darauf geachtet werden, dass im Bereich der Betriebstemperatur ($30^{\circ}\text{C} \pm 90^{\circ}\text{C}$) ein Druckabfall von insgesamt 2 ± 3 Bar in der Leitung nicht überschritten wird.

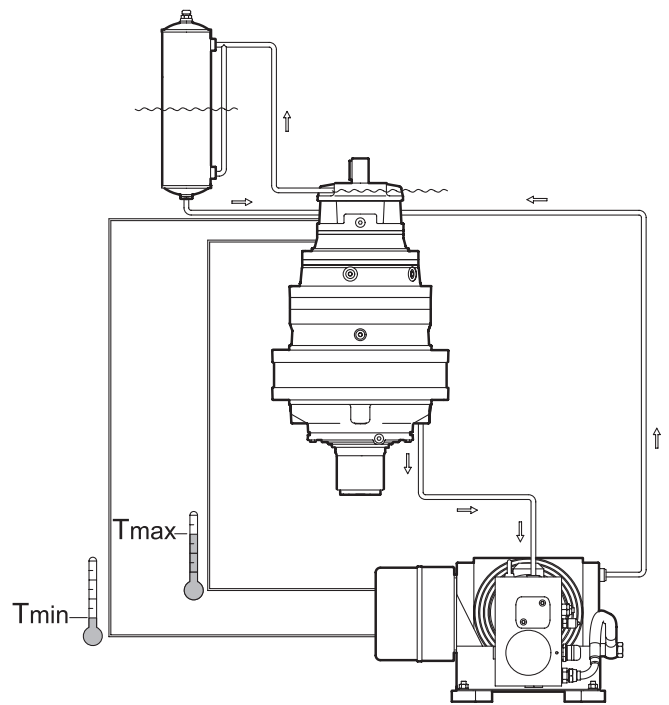
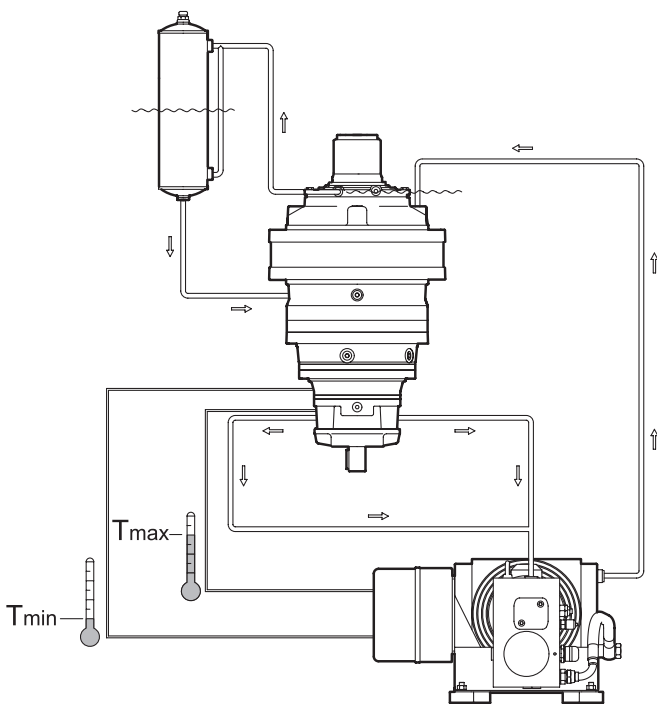
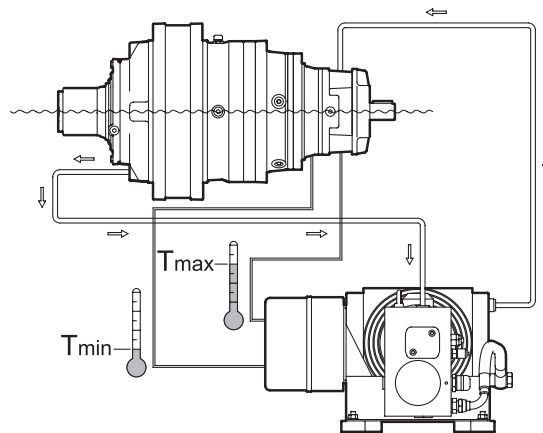

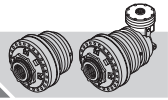

FR ES PT

La figure montre des exemples de raccordement du système auxiliaire de refroidissement au réducteur, où l'on peut voir les raccords hydrauliques d'aspiration et de refoulement et les branchements électriques des thermostats qui régulent le fonctionnement du système.

Le dimensionnement des tuyaux de refoulement doit tenir compte de la distance entre unité de refroidissement et réducteur, en veillant à ne pas dépasser, sur la plage des températures de fonctionnement ($30^{\circ}\text{C} \div 90^{\circ}\text{C}$), une baisse de pression totale de la ligne de 2÷3 bars.

En la figura se presentan algunos ejemplos de conexión con el reductor del sistema auxiliar de refrigeración, ejemplos en los cuales se muestran las conexiones hidráulicas de aspiración e impulsión y las conexiones eléctricas de los termostatos que regulan el funcionamiento del sistema.

El dimensionamiento de la tubería de impulsión debe tener en cuenta la distancia entre la unidad de refrigeración y el reductor, procurando no superar, en el rango de temperatura de funcionamiento ($30^{\circ}\text{C} \div 90^{\circ}\text{C}$), una caída de presión total de la línea de 2÷3 bar.

Na figura estão indicados alguns exemplos de ligação do sistema auxiliar de arrefecimento ao redutor, no qual estão ilustradas as ligações hidráulicas de aspiração e ida e as ligações elétricas dos termostatos que regulam o funcionamento do sistema.

O dimensionamento da tubagem de ida deve tomar em consideração a distância entre a unidade de arrefecimento e o redutor, prestando atenção para não superar, no campo de temperatura de exercício ($30^{\circ}\text{C} \div 90^{\circ}\text{C}$), uma queda de pressão total da linha de 2÷3 bar.

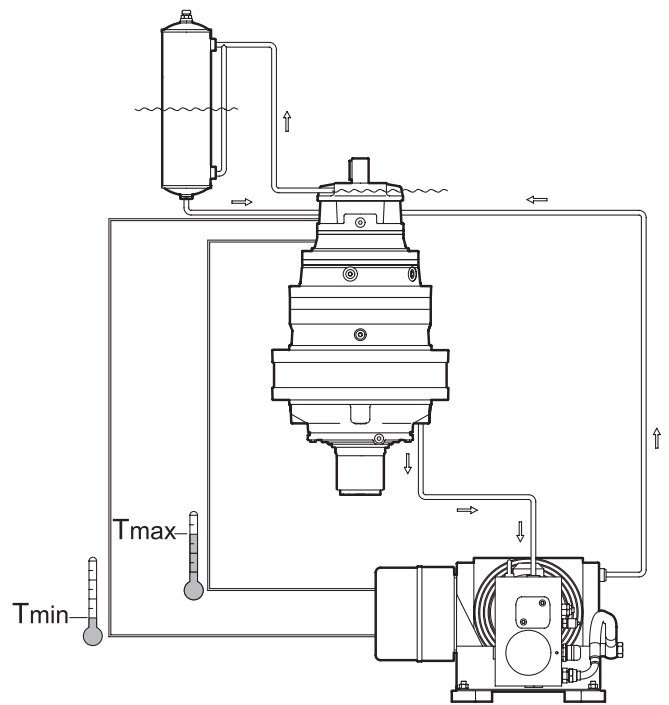
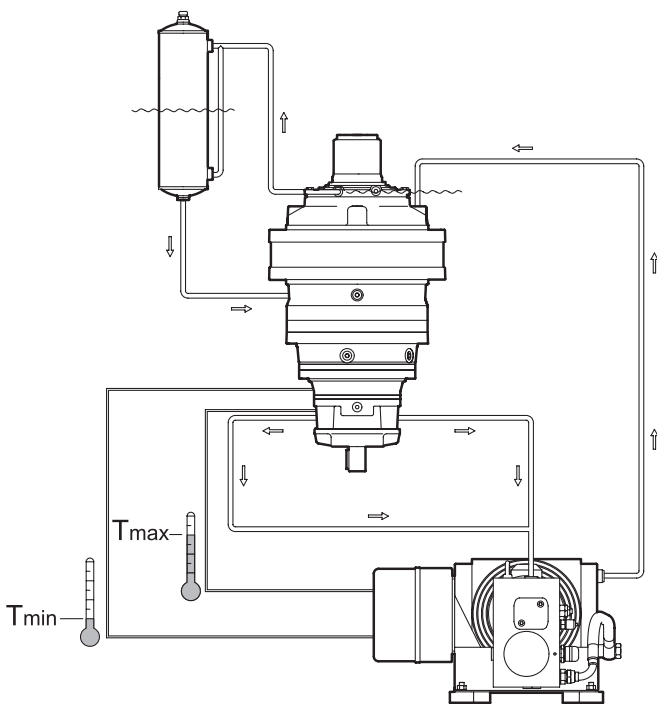
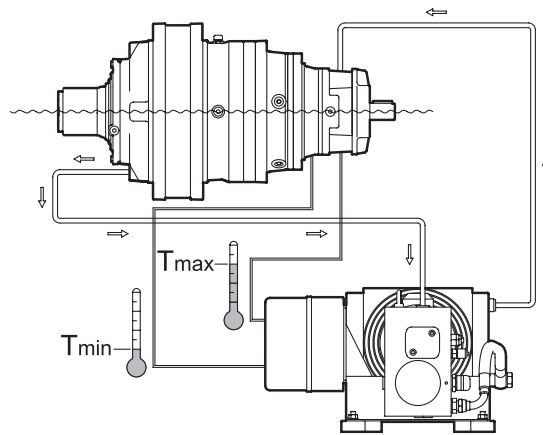

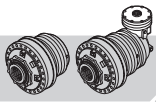

7 IMBALLO, MOVIMENTAZIONE E STOCCAGGIO

I prodotti Reggiana Riduttori vengono imballati e spediti in casse o su pallets. L'imballo è realizzato in maniera da resistere alle condizioni dei normali ambienti industriali. In caso di ambienti particolarmente ostili occorre predisporre opportune misure di protezione.

I riduttori vengono avvolti in sacchi di plastica e, nel caso di imballaggio in casse, viene introdotto del polistirolo o altro materiale per attutire gli urti.

7.1 Movimentazione

Eseguire la movimentazione dei colli con attrezzature e mezzi di sollevamento idonei al tipo di imballo.

Tenere conto della massa, dell'ingombro, dei punti di presa e della posizione del baricentro; questi dati, se necessari, sono indicati esternamente al collo.



La movimentazione deve essere affidata a personale esperto, che operi nel rispetto delle norme antinfortunistica, per garantire la propria sicurezza e quella delle persone presenti nelle vicinanze.

Per la movimentazione attenersi alle seguenti disposizioni:

- individuare un'area con superficie possibilmente piana e sufficientemente grande per contenere i colli, sulla quale effettuare lo scarico;
- non inclinare o capovolgere i colli durante il sollevamento e lo spostamento;
- procedere con cautela durante il posizionamento dei colli, evitando movimenti bruschi ed impatti violenti.

Per la rimozione dei riduttori dal loro imballo, utilizzare accessori idonei (catene, fasce, funi, golfari, ganci, etc.), e fare in modo da avere il carico sempre bilanciato.

7 PACKING, HANDLING AND STORING

Reggiana Riduttori products are packed and shipped in crates or on pallets. Packaging is made to withstand the conditions of normal industrial environments. However, suitable protection measures must be taken if environmental conditions are particularly bad.

The reduction gears are wrapped in plastic bags and, if they're being packed in crates, polystyrene or other similar material is put inside to soften knocks.

7.1 Handling

Handle the packs with equipment and lifting means that are suitable for this type of packaging.

Take into account the mass, dimensions, points for lifting and the barycentre; these data, if necessary, are indicated outside of the pack.

Handling must be entrusted to expert personnel who must work in compliance with the accident prevention rules and regulations so as to guarantee their own safety and that of others in the vicinity.

Follow these instructions for handling:

- *find an area where the surface is flat and possibly big enough for unloading and depositing the packs;*
- *do not tilt or turn the packs upside down when lifting and moving;*
- *proceed with caution when positioning the packs, avoiding sudden movements and violent knocks.*

Use suitable tools to take the reduction gears out of their packaging (chains, straps, ropes, eyebolts, hooks, etc.) and make sure the load is always balanced.

7 VERPACKUNG, TRANSPORT UND LAGERUNG

Die Produkte von Reggiana Riduttori werden in Kisten oder auf Paletten verpackt und ausgeliefert.

Die Verpackung erfolgt so, dass sie den normalen Bedingungen an industriellen Standorten standhält. Bei besonders widrigen Umgebungen müssen entsprechende Schutzmaßnahmen ergriffen werden. Die Planetengetriebe sind mit Plastikplatten geschützt und bei der Verpackung in Kisten werden sie durch Styropor oder ein ähnliches Material gegen Stöße geschützt.

7.1 Transport

Der Transport darf ausschließlich mit geeigneten Hebevorrichtungen durchgeführt werden.

Das Gewicht, die Abmessungen, die Hebeplätze und die Lage vom Schwerpunkt müssen beachtet werden. Entsprechende Angaben befinden sich außen auf der Packung.

Der Transport darf ausschließlich von kompetentem Personal unter Beachtung der geltenden Unfallverhütungsvorschriften vorgenommen werden, um für die Sicherheit vom Personal und aller in der Nähe befindlichen Personen zu garantieren.

Hinweise für den korrekten Transport:

- Das Abladen an einem Ort durchführen, der möglichst eben ist und ausreichend Platz für die Kisten bzw. Paletten bietet;
- Die Kisten bzw. Paletten beim Anheben und Transportieren nicht in eine schräge Position bringen oder kippen;
- Die Kisten bzw. Paletten mit der gebotenen Vorsicht absetzen. Heftige Bewegungen und Stöße vermeiden.

Das Planetengetriebe mit geeigneten Hebevorrichtungen (Ketten, Gurte, Seile, Ringschrauben, Haken, usw.) aus der Kiste nehmen. Sicherstellen, dass sich die Last im Gleichgewicht befindet.



7 EMBALLAGE, MANUTENTION ET STOCKAGE

Les produits Reggiana Riduttori sont emballés et expédiés en caisses ou sur palettes. Tous les produits sont emballés avec des matériaux adaptés pour résister à des environnements industriels normaux. En cas d'atmosphères particulièrement hostiles, prévoir les mesures de protection appropriées.

Les réducteurs sont enveloppés dans un sac en plastique et, dans le cas d'emballage en caisses, ils seront protégés avec du polystyrène ou un autre matériau permettant d'atténuer les chocs.

7.1 Manutention

Exécuter la manutention des colis à l'aide d'engins de levage appropriés au type d'emballage.

Tenir compte de la masse, des dimensions, des endroits de prise et de la position du barycentre; si besoin est, ces données sont indiquées à l'extérieur du colis.



La manutention doit être faite par un personnel qualifié qui travaille dans le respect des règles pour la prévention des accidents, afin de garantir sa propre sécurité et celle des personnes qui l'entourent.

Pour la manutention, se conformer aux dispositions suivantes:

- choisir des locaux dont la surface est plane et suffisamment grande pour contenir les colis, pour effectuer le déchargement;
- ne pas incliner ni renverser les colis au moment du levage et du déplacement;
- faire attention au moment du positionnement des colis; éviter tout mouvement brusque et tout impact violent.

Pour enlever les réducteurs de leur emballage, utiliser des accessoires appropriés (chaînes, courroies, cordes, pitons à œil, crochets, etc.), et faire en sorte que la charge soit toujours équilibrée.

7 EMBALAJE, DESPLAZAMIENTO Y ALMACENAMIENTO

Los productos Reggiana Riduttori son embalados y enviados en cajas o sobre paletas. El embalaje está realizado de manera que resista a las condiciones de los normales ambientes industriales. En caso de ambientes particularmente hostiles es necesario predisponer oportunas medidas de protección.

Los reductores vienen envueltos en sacos de plástico y, en el caso de embalaje en caja, se pone poliestireno u otro material para amortiguar los golpes.

7.1 Desplazamiento

Efectuar el desplazamiento de los bultos utilizando equipos y medios de elevación adecuados para el tipo de embalaje.

Tener en cuenta la masa, las medidas máximas, los puntos de agarre y la posición del baricentro; estos datos, si necesario, vienen indicados al exterior del bulto.

El desplazamiento debe ser confiado a personal experto, que trabaje respetando las normas de prevención de accidentes, para garantizar la propia seguridad y aquella de las personas presentes en las cercanías.

Para el desplazamiento ajustarse a las siguientes disposiciones:

- *individuar un área con una superficie a ser posible plana y suficientemente grande para contener los bultos, sobre la cual efectuar la descarga;*
- *no inclinar ni volcar los bultos durante la elevación y el desplazamiento;*
- *proceder con cautela durante la colocación de los bultos, evitando movimientos bruscos y golpes violentos.*

Para sacar los reductores de su embalaje, utilizar accesorios adecuados (cadenas, eslingas, cables, cáncamos, ganchos, etc.), y procurar tener la carga siempre equilibrada.

7 EMBALAGEM, MOVIMENTAÇÃO E ARMAZENAGEM

Os produtos Reggiana Riduttori são embalados e expedidos em caixas ou sobre paletes. A embalagem é realizada de modo a resistir às condições dos normais ambientes industriais. No caso de ambientes particularmente agressivos é necessário adotar oportunas medidas de proteção.

Os redutores são envolvidos em sacos de plástico e, no caso de embalagem em caixas, é introduzido esferovit ou outro material para atenuar os choques.

7.1 Movimentação

Efetuar a movimentação dos volumes com equipamento e meios de levantamento idóneos ao tipo de embalagem.

Tomar em consideração a massa, o volume, os pontos de tomada e a posição central dos componentes; estes dados, se necessários, estão indicados na parte externa dos volumes.

A movimentação deve ser feita por pessoal competente, que trabalhe no respeito das normas de segurança contra acidentes, para garantir a própria segurança e aquela das pessoas presentes nas proximidades

Para a movimentação respeitar as seguintes disposições:

- Identificar uma área com superfície possivelmente plana e suficientemente grande para conter os volumes e na qual descarregar;
- não inclinar ou voltar os volumes durante o levantamento e a deslocação;
- proceder com cautela durante o posicionamento dos volumes, evitando movimentos bruscos e choques violentos.

Para a extração dos redutores da sua embalagem, utilizar acessórios idóneos (correntes, cintas, cabos, anéis, ganchos, etc.), e proceder de modo a ter sempre a carga sempre bem equilibrada.

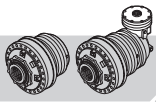

7.2 Stoccaggio

Evitare lo stoccaggio dei riduttori epicycloidali in ambienti aperti o soggetti ad eccessiva umidità; non lasciare mai i riduttori a contatto diretto con il suolo.

Per periodi di stoccaggio superiori a due mesi attenersi alle seguenti indicazioni:

- effettuare il riempimento del riduttore con olio lubrificante del tipo previsto ed orientare il riduttore in modo che il tappo di sfiato sia posto in alto;
- proteggere le superfici esterne di accoppiamento con grasso o con apposito prodotto antiossidante;
- effettuare lo stoccaggio in luogo asciutto e pulito, con temperature comprese tra -15°C e $+50^{\circ}\text{C}$.

7.3 Disimballaggio

Al ricevimento della merce occorre verificare la corrispondenza tra quanto indicato sulla targhetta e le specifiche dell'ordine; verificare, inoltre, che il contenuto dell'imballo non abbia subito danneggiamenti durante il trasporto.

7.4 Smaltimento in sicurezza dei materiali di imballaggio

I materiali che costituiscono l'imballo vanno smaltiti secondo le vigenti norme in materia di ambiente.

7.2 Storing

Do not store the planetary reduction gears in the open or where they would be subject to excessive dampness; never leave the reduction gears in direct contact with the ground.

If storing for more than two months, proceed as follows:

- *fill the reduction gear with lubricant oil of the type foreseen and position the reduction gear so the venting plug is on top;*
- *protect the outside coupling surfaces with grease or a rustproof product;*
- *store in a dry, clean place where the temperature is between -15°C e $+50^{\circ}\text{C}$.*

7.3 Unpacking

When the goods are received they must be checked to see that they correspond to what is specified on the plate and in the order; also check that the contents of the pack have not been damaged during transport.

7.4 Disposing of the packaging materials safely

The packaging materials must be disposed of in accordance with the current environmental protection laws.

7.2 Lagerung

Die Planetengetriebe nicht im Freien oder an Orten mit hoher Luftfeuchtigkeit lagern. Die Planetengetriebe auf keinen Fall direkt auf dem Boden ablegen.

Bei Lagerung über einen Zeitraum von mehr als zwei Monaten folgende Anweisungen beachten:

- Das Schmieröl vom empfohlenen Typ in das Planetengetriebe füllen und dieses so abstellen, dass die Entlüftungsdeckel nach oben zeigen.
- Die Außenseite vom Planetengetriebe mit Schmierfett oder einem geeigneten Rostschutzmittel schützen;
- Das Planetengetriebe an einem trockenen, sauberen Ort bei einer Temperatur von -15°C bis $+50^{\circ}\text{C}$ lagern.

7.3 Entnahme aus der Verpackung

Beim Empfang der Ware die Übereinstimmung der Angaben auf dem Typenschild mit den Spezifikationen der Bestellung überprüfen. Sicherstellen, dass der Inhalt der Verpackung während des Transports nicht beschädigt wurde.

7.4 Sichere Entsorgung der Verpackungsmaterialien

Die Verpackungsmaterialien müssen unter Beachtung der geltenden Umweltschutzbestimmungen entsorgt werden.

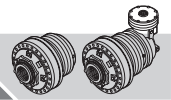

7.2 Stockage

Eviter de stocker les réducteurs épicycloïdaux dans des endroits ouverts ou sujets à un taux d'humidité excessif; ne pas laisser les réducteurs au contact direct du sol.

Pour des périodes de stockage de plus de deux mois, se conformer aux indications suivantes.

- effectuer le nourrissage du réducteur avec de l'huile de lubrification du type prévu et orienter le réducteur de manière que le bouchon d'évent soit positionné vers le haut;
- protéger les surfaces extérieures d'accouplement avec de la graisse ou un produit spécial anti-oxydant;
- effectuer le stockage dans un endroit sec et propre et dont les températures sont comprises entre -15°C et +50°C.

7.3 Décaissement

Lors de la réception de la marchandise, contrôler si la fourniture correspond bien aux indications qui figurent sur la plaque et sur la commande; vérifier aussi si le contenu de l'emballage a été endommagé pendant le transport.

7.4 Élimination en toute sécurité des matériaux composant l'emballage

Les matériaux qui composent l'emballage doivent être éliminés conformément aux normes pour la protection de l'environnement en vigueur dans le pays où la machine est installée.

7.2 Almacenamiento

Evitar almacenar los reductores epicicloidales al aire libre o en lugares con una excesiva humedad; no dejar nunca los reductores en contacto directo con el suelo.

Para periodos de almacenamiento de más de dos meses, ajustarse a las siguientes indicaciones:

- *efectuar el llenado del reductor con aceite lubricante del tipo previsto y orientar el reductor de manera que el tapón de purga quede en la parte alta;*
- *proteger las superficies externas de acoplamiento con grasa o con un adecuado producto antioxidante;*
- *efectuar el almacenamiento en un lugar seco y limpio, con temperaturas entre -15°C e +50°C.*

7.3 Desembalaje

Al recibir la mercancía es necesario comprobar que se corresponda cuanto indicado en la placa con las especificaciones del pedido; comprobar así mismo que el contenido del embalaje no haya sufrido daños durante el transporte

7.4 Eliminación segura de los materiales de embalaje

Los materiales que componen el embalaje deben eliminarse conforme a las normas vigentes en materia de medio ambiente.

7.2 Armazenagem

Evitar a armazenagem dos redutores epicicloidais em ambientes ao ar livre ou sujeitos a excessiva umidade; nunca deixar os redutores em contato direto com o chão.

Por períodos de armazenagem superiores a dois meses respeitar as seguintes instruções:

- efetuar o enchimento do redutor com óleo lubrificante do tipo previsto e regular o redutor de modo que o tampão de resfolgo fique voltado para cima.
- proteger as superfícies externas de acoplamento com graxa ou com produto específico anti-oxidante;
- efetuar a armazenagem em lugar enxuto e limpo, com temperaturas compreendidas entre -15°C e + 50°C.

7.3 Retiro da embalagem

À recepção da mercadoria é necessário verificar a correspondência entre quanto indicado na placa contendo os dados técnicos e as especificações constantes na ordem; verificar, também, que o conteúdo da embalagem não tenha sofrido danos durante o transporte.

7.4 Eliminação em segurança dos materiais de embalagem

Os materiais que constituem a embalagem devem ser eliminados de acordo com quanto estabelecido pelas normas vigentes em matéria de proteção do ambiente.

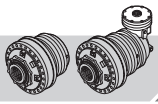

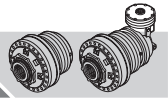

B

Dati tecnici e dimensionali
Technical and size data
Technische daten und Abmessungen
Données techniques et dimensionnelles
Datos técnicos y dimensionales
Dados técnicos e dimensões

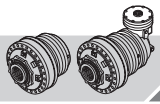

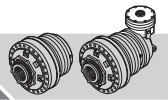

| Grandezza / Size / Größe Grandeur / Talla / Grandeza | T_{2n} [Nm] | Pag. / Page / Seite Page / Pag. / Pag. |
|---|---------------|---|
| 65 | 680 | B4 |
| 105 | 850 | B14 |
| 110 | 1000 | B26 |
| 210 | 1650 | B38 |
| 310 | 2600 | B50 |
| 510 | 4800 | B64 |
| 710 | 5300 | B78 |
| 810 | 8500 | B92 |
| 1010 | 13500 | B106 |
| 1700 | 18100 | B120 |



RR65

..

i

| | i 1/... | T ₂ [Nm] | | | | | | n _{1max} [min ⁻¹] | T _{2max} [Nm] | P _t [kW] |
|---------------|---------------|-----------------------------|-----------------------------------|---------------------------------|------------------------------|----------------------------------|-------------------------------|---|---------------------------|------------------------|
| | | n ₂ x h | | | | | | | | |
| | | 10000 (10 ⁴) | 25000 (2.5 · 10 ⁴) | 50000 (5 · 10 ⁴) | 100000 (10 ⁵) | 500000 (5 · 10 ⁵) | 1000000 (10 ⁶) | | | |
| RR65 | 3.51 | 760 | 710 | 690 | 650 | 580 | 520 | 3500 | 1200 | 9 |
| | 4.65 | 800 | 680 | 580 | 530 | 480 | 460 | 3500 | | 9 |
| | 6.21 | 560 | 460 | 400 | 380 | 340 | 330 | 3500 | | 9 |
| RR65 D | 12.32 | 760 | 710 | 690 | 650 | 580 | 520 | 3500 | 1200 | 5 |
| | 16.32 | 760 | 710 | 690 | 650 | 580 | 520 | 3500 | | 5 |
| | 21.62 | 800 | 680 | 580 | 530 | 480 | 460 | 3500 | | 5 |
| | 28.88 | 800 | 680 | 580 | 530 | 480 | 460 | 3500 | | 5 |
| | 38.56 | 560 | 460 | 400 | 380 | 340 | 330 | 3500 | | 5 |
| RR65 T | 43.24 | 760 | 710 | 690 | 650 | 580 | 520 | 3500 | 1200 | 4 |
| | 57.29 | 760 | 710 | 690 | 650 | 580 | 520 | 3500 | | 4 |
| | 75.89 | 760 | 710 | 690 | 650 | 580 | 520 | 3500 | | 4 |
| | 101.36 | 760 | 710 | 690 | 650 | 580 | 520 | 3500 | | 4 |
| | 134.28 | 800 | 680 | 580 | 530 | 480 | 460 | 3500 | | 4 |
| | 179.32 | 800 | 680 | 580 | 530 | 480 | 460 | 3500 | | 4 |
| | 239.48 | 560 | 460 | 400 | 380 | 340 | 330 | 3500 | | 4 |



RR65 .. i ..

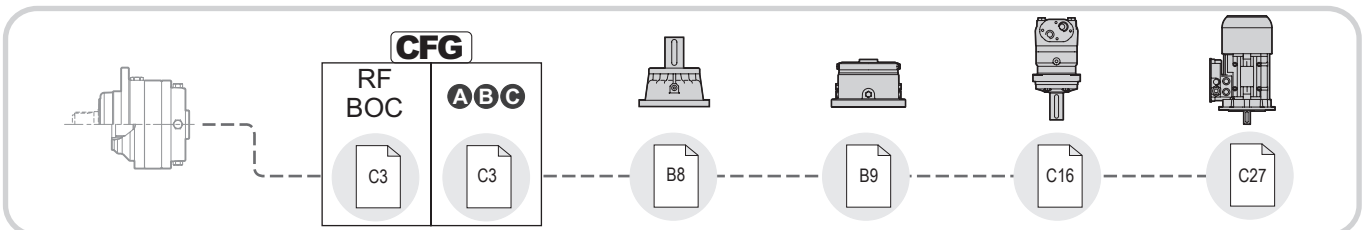
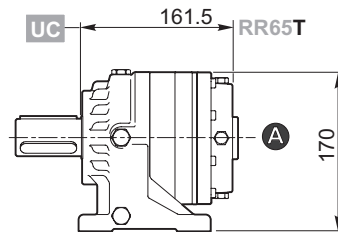
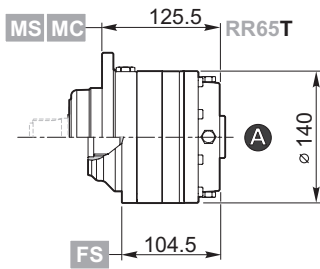
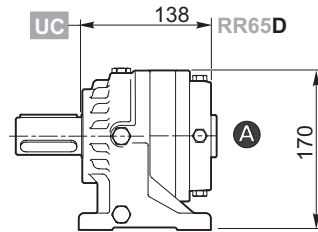
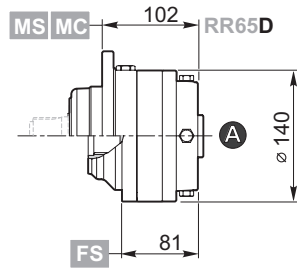
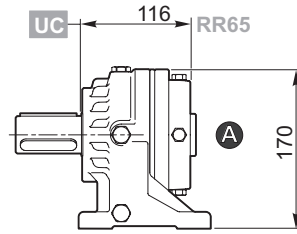
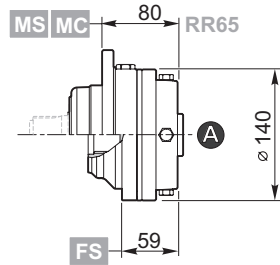
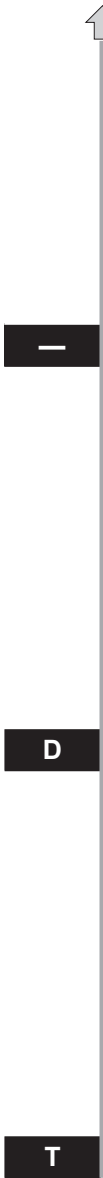



RR65 .. i ..

MS
MC

UC

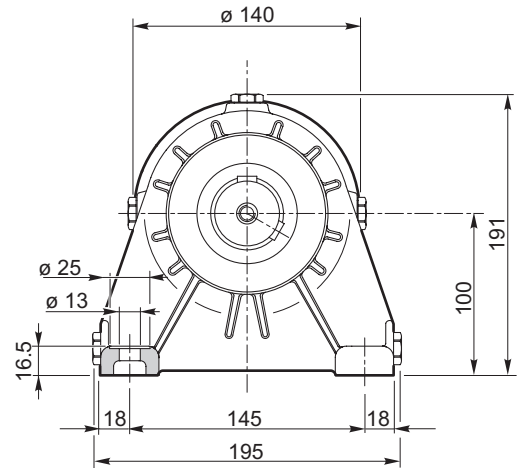
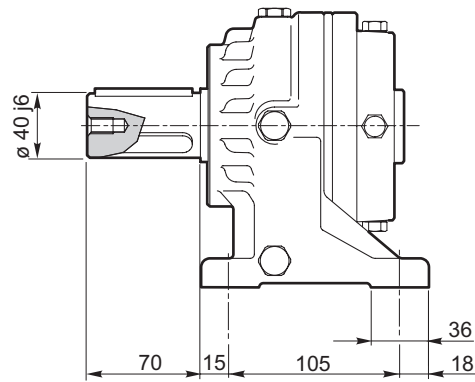
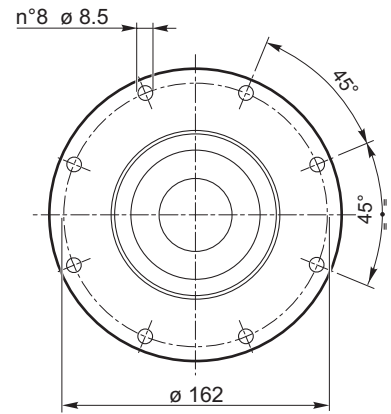
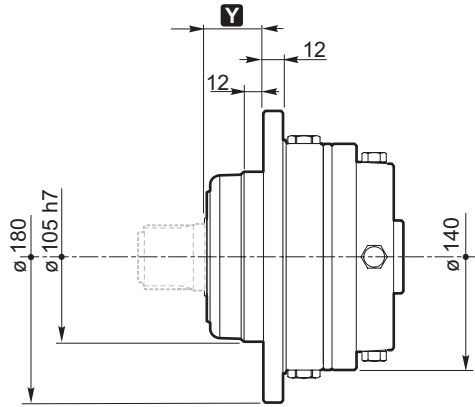



MS

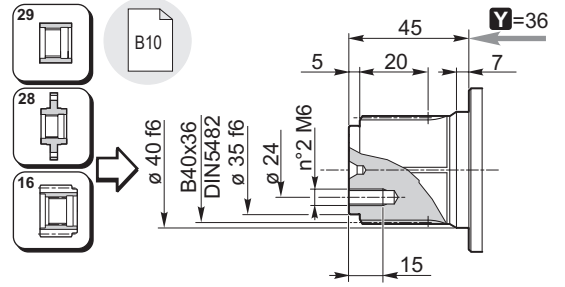
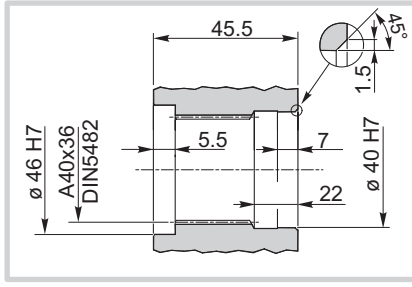
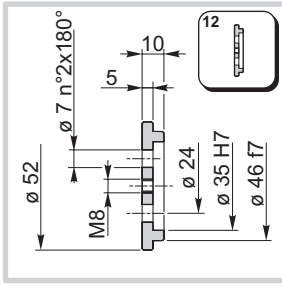

MC
UC

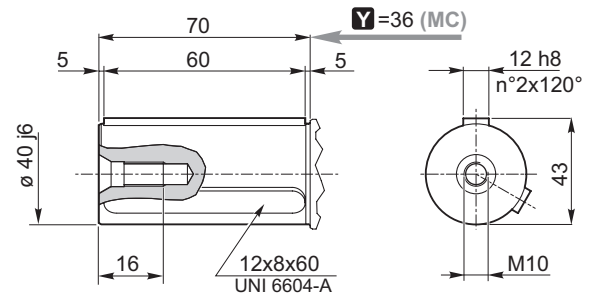
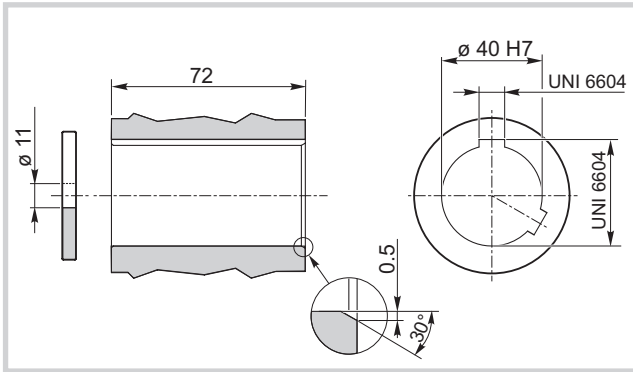



RR65 .. i **FS**

FS

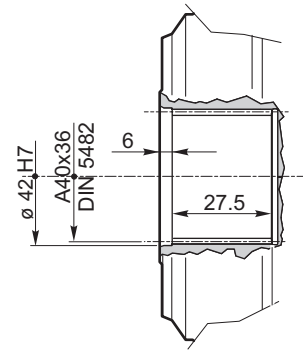
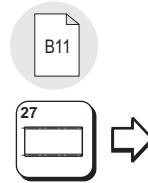
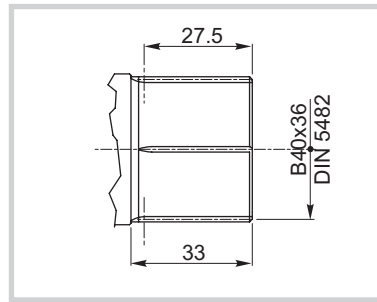
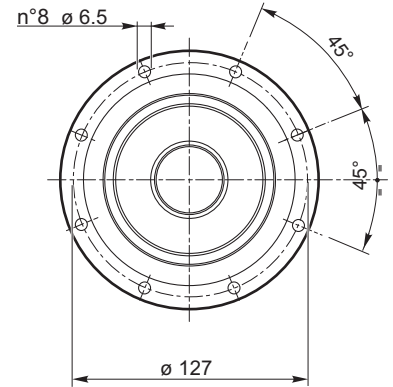
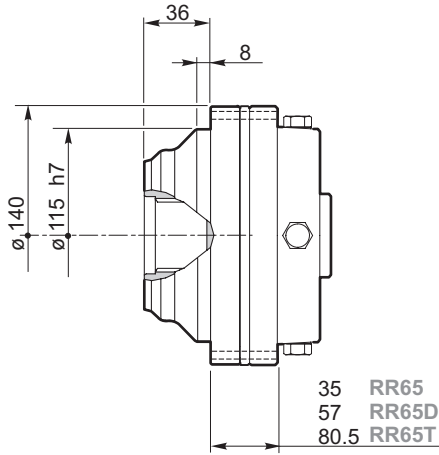

L35-1

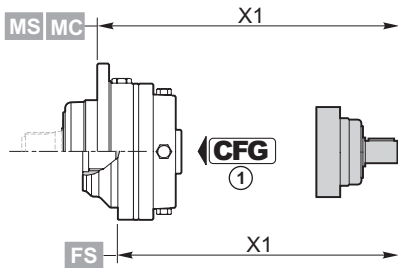
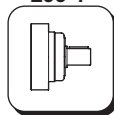

| CFG | |
|--------|--|
| RF BOC | |
| A | |
| B | |
| C | |

| | CFG | | code | X1 |
|------------|-----|-------|------------|-------|
| | ① | | | |
| RR65 M... | RF | L35-1 | 154B4054 | 168 |
| RR65D M... | RF | L35-1 | 154B4054M1 | 190 |
| RR65T M... | RF | L35-1 | 154B4054M2 | 213.5 |
| RR65 FS | RF | L35-1 | 154B4058 | 147 |
| RR65D FS | RF | L35-1 | 154B4059 | 169 |
| RR65T FS | RF | L35-1 | 154B4060 | 192.5 |

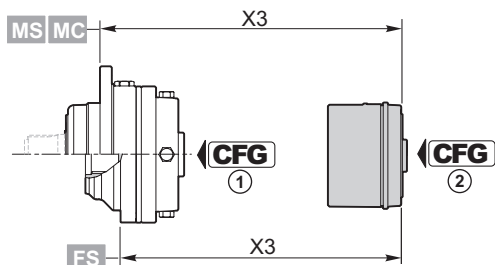
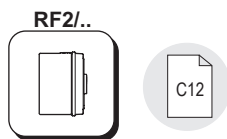

| | |
|----------------------------------|--|
| CFG | |
| RF BOC | |
| A B C | |

| RF2/.. | CFG ① | T _f [Nm] | CFG ② | | | | |
|------------|-------|------------------------|-------------|-------|-----------------------------|------------------------------|-------|
| | | | A | | OMP/OMR SAE A 2B Ø 25 | OMP/OMR SAE A 2B 1" 6B | |
| | | | code | X3 | code | code | |
| RR65 M... | RF | 70 | 154-2832M1 | 146 | 154-2858M1 | 154-2858M5 | 141.5 |
| | | 140 | 154-2833M1 | | 154-2859M1 | 154-2859M5 | |
| | | 210 | 154-2834M1 | | 154-2860M1 | 154-2860M5 | |
| | | 320 | 154-2836M1 | | 154-2861M1 | 154-2861M5 | |
| | | 430 | 154-2837M1 | | 154-2862M1 | 154-2862M5 | |
| | | 600 | 154B8959M1 | | 154B9663M1 | 154B9663M5 | |
| RR65 FS | RF | 70 | 154-2832M2 | 125 | 154-2858M2 | 154-2858M6 | 120.5 |
| | | 140 | 154-2833M2 | | 154-2859M2 | 154-2859M6 | |
| | | 210 | 154-2834M2 | | 154-2860M2 | 154-2860M6 | |
| | | 320 | 154-2836M2 | | 154-2861M2 | 154-2861M6 | |
| | | 430 | 154-2837M2 | | 154-2862M2 | 154-2862M6 | |
| | | 600 | 154B8959M2 | | 154B9663M2 | 154B9663M6 | |
| RR65D M... | RF | 70 | 154-2832M3 | 168 | 154-2858M3 | 154-2858M7 | 163.5 |
| | | 140 | 154-2833M3 | | 154-2859M3 | 154-2859M7 | |
| | | 210 | 154-2834M3 | | 154-2860M3 | 154-2860M7 | |
| | | 320 | 154-2836M3 | | 154-2861M3 | 154-2861M7 | |
| | | 430 | 154-2837M3 | | 154-2862M3 | 154-2862M7 | |
| | | 600 | 154B8959M3 | | 154B9663M3 | 154B9663M7 | |
| RR65D FS | RF | 70 | 154-2832M4 | 147 | 154-2858M4 | 154-2858M8 | 142.5 |
| | | 140 | 154-2833M4 | | 154-2859M4 | 154-2859M8 | |
| | | 210 | 154-2834M4 | | 154-2860M4 | 154-2860M8 | |
| | | 320 | 154-2836M4 | | 154-2861M4 | 154-2861M8 | |
| | | 430 | 154-2837M4 | | 154-2862M4 | 154-2862M8 | |
| | | 600 | 154B8959M4 | | 154B9663M4 | 154B9663M8 | |
| RR65T M... | RF | 70 | 154-2832M10 | 191.5 | 154-2858M10 | 154-2858M12 | 187.0 |
| | | 140 | 154-2833M10 | | 154-2859M10 | 154-2859M12 | |
| | | 210 | 154-2834M10 | | 154-2860M10 | 154-2860M12 | |
| | | 320 | 154-2836M10 | | 154-2861M10 | 154-2861M12 | |
| | | 430 | 154-2837M10 | | 154-2862M10 | 154-2862M12 | |
| | | 600 | 154B8959M10 | | 154B9663M10 | 154B9663M12 | |
| RR65T FS | RF | 70 | 154-2832M11 | 170.5 | 154-2858M11 | 154-2858M13 | 166.0 |
| | | 140 | 154-2833M11 | | 154-2859M11 | 154-2859M13 | |
| | | 210 | 154-2834M11 | | 154-2860M11 | 154-2860M13 | |
| | | 320 | 154-2836M11 | | 154-2861M11 | 154-2861M13 | |
| | | 430 | 154-2837M11 | | 154-2862M11 | 154-2862M13 | |
| | | 600 | 154B8959M11 | | 154B9663M11 | 154B9663M13 | |



Kg 0.1

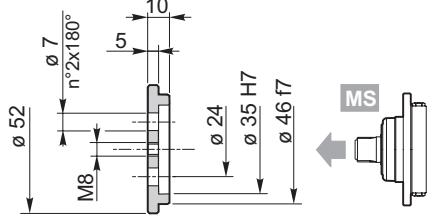

154-3063

Materiale / Material / Material / Matériau / Material / Material:
 Acciaio / Steel / Stahl / Acier / Acero / Aço
 C40 EN 10083-1 (1.1186)

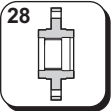

Kg 1.6

Materiale / Material / Material / Matériau / Material / Material: **Acciaio / Steel / Stahl / Acier / Acero / Aço EN 10083-1-C40 (1.1186)**

Trattamento termico:
 Tempra ad induzione secondo UNI 10932 su scanalato interno

Heat treatment:
 Induction hardening according to UNI 10932 on internal spline

Wärmebehandlung:
 Induktionshärtung nach UNI 10932 an interner Nut

Traitement thermique :
 Trempe par induction conformément à la norme UNI 10932 sur cannelé interne

Tratamiento térmico:
 Temple por inducción según UNI 10932 en acanalado interno

Tratamento térmico:
 Tempera por indução segundo UNI 10932 sobre ranhuras internas

154-3113

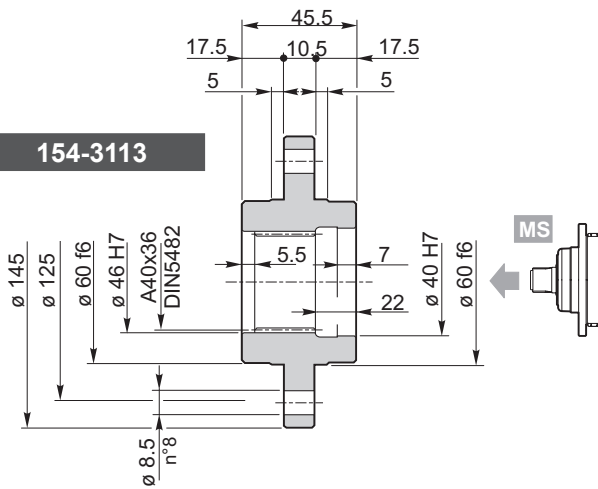

Kg 0.5

Materiale / Material / Material / Matériau / Material / Material: **Acciaio / Steel / Stahl / Acier / Acero / Aço 39NiCrMo3 UNI 7845 (1.6511)**

Trattamento termico:
 Tempra ad induzione secondo UNI 10932 su scanalato interno

Heat treatment:
 Induction hardening according to UNI 10932 on internal spline

Wärmebehandlung:
 Induktionshärtung nach UNI 10932 an interner Nut

Traitement thermique :
 Trempe par induction conformément à la norme UNI 10932 sur cannelé interne

Tratamiento térmico:
 Temple por inducción según UNI 10932 en acanalado interno

Tratamento térmico:
 Tempera por indução segundo UNI 10932 sobre ranhuras internas

154-3094

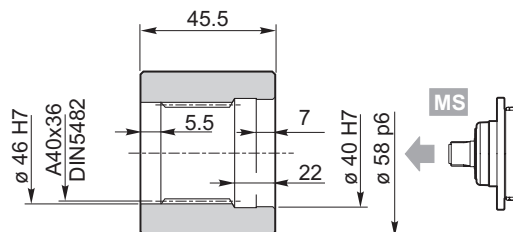

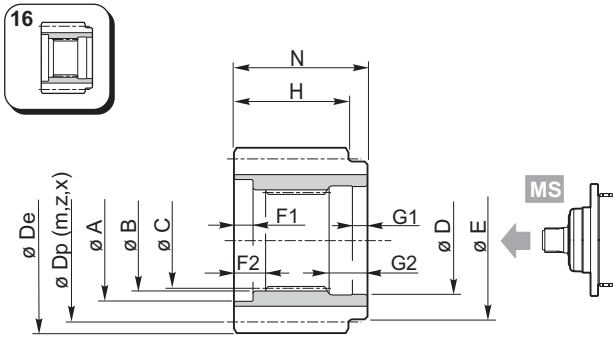

Materiale / Material / Material
Matériau / Material / Material
Acciaio / Steel / Stahl / Acier / Acero / Aço
39NiCrMo3 UNI 7845 (1.6511)

Trattamento termico:
 Tempra ad induzione secondo UNI 10932 su scanalato interno

Heat treatment:
 Induction hardening according to UNI 10932 on internal spline

Wärmebehandlung:
 Induktionshärtung nach UNI 10932 an interner Nut

Traitement thermique :
 Trempe par induction conformément à la norme UNI 10932 sur cannelé interne

Tratamiento térmico:
 Temple por inducción según UNI 10932 en acanalado interno

Tratamento térmico:
 Tempera por indução segundo UNI 10932 sobre ranhuras internas

| | A | B | C | D | E | F1 | F2 | G1 | G2 | N | m | z | x | H | Dp | De | Code |
|-----------|----|-------|-------------------|-------|----|----|-----|----|----|------|---|----|------|------|-----|------|-----------------|
| MS | 53 | 46 F6 | DIN5482 A40x36 | 40 F6 | 50 | 2 | 7.5 | 7 | 21 | 47.5 | 4 | 15 | 0.5 | 44.5 | 60 | 69.8 | 154-3072 |
| | 53 | 46 F6 | DIN5482 A40x36 | 40 F6 | 50 | 2 | 7.5 | 7 | 21 | 47.5 | 4 | 32 | 0 | 44.5 | 128 | 135 | 154-3104 |
| | 53 | 46 F6 | DIN5482 A40x36 | 40 F6 | 50 | 2 | 7.5 | 7 | 21 | 47.5 | 6 | 12 | 0.25 | 44.5 | 72 | 84.8 | 154-3073 |
| | 53 | 46 F6 | DIN5482 A40x36 | 40 F6 | 50 | 2 | 7.5 | 7 | 21 | 47.5 | 5 | 14 | 0.5 | 44.5 | 70 | 84 | 154-2709 |
| | 53 | 46 F6 | DIN5482 A40x36 | 40 F6 | 50 | 2 | 7.5 | 7 | 21 | 47.5 | 6 | 24 | 0 | 44.5 | 144 | 154 | 154-2285 |
| | 53 | 46 F6 | DIN5482 A40x36 | 40 F6 | 50 | 2 | 7.5 | 7 | 21 | 47.5 | 8 | 16 | 0.25 | 44.5 | 128 | 145 | 154-2707 |

27

Kg 0.9

154-3050

Materiale / Materiale / Material
Matériau / Material / Material:
Acciaio / Steel / Stahl / Acier / Acero / Aço
39NiCrMo3 UNI 7845 (1.6511)



| | | | |
|----|----|----|-----------|
| RR | 65 | .. | MS |
| | | | MC |

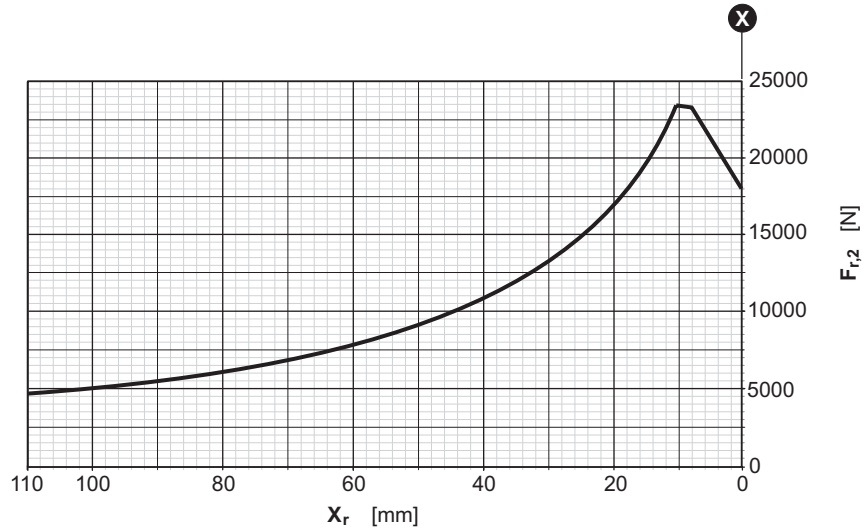
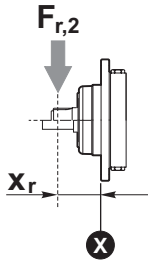

| | | | |
|----|----|----|-----------|
| RR | 65 | .. | UC |
|----|----|----|-----------|

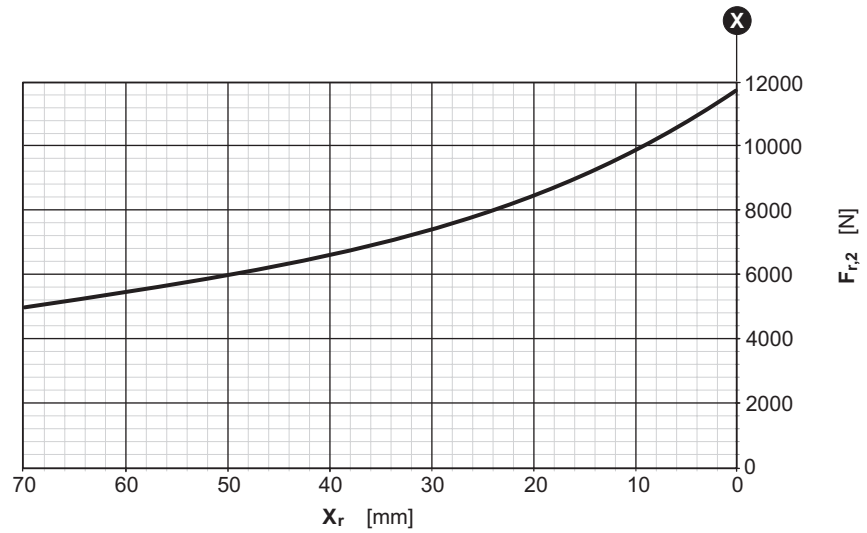
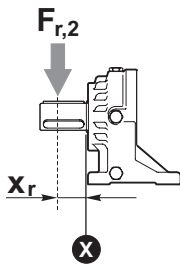

Fattore correttivo $k_{r,2}$ / $k_{r,2}$ Corrective coefficient / Korrekturfaktor $k_{r,2}$
 Facteur correctif $k_{r,2}$ / Factor de corrección $k_{r,2}$ / Fator corretivo $k_{r,2}$

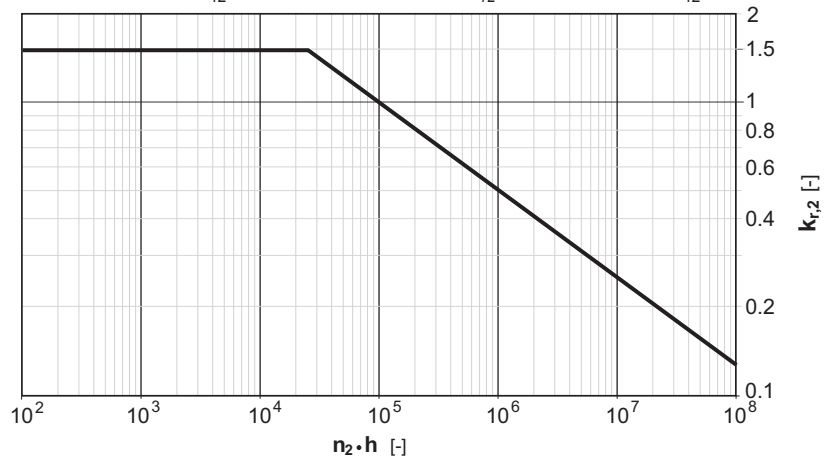





RR105 .. **i**



| i | T ₂ [Nm] | | | | | | n _{1max} [min ⁻¹] | T _{2max} [Nm] | P _t [kW] | |
|---------------|-----------------------------|-----------------------------------|---------------------------------|------------------------------|----------------------------------|-------------------------------|---|---------------------------|------------------------|----|
| | n ₂ x h | | | | | | | | | |
| 1/... | 10000 (10 ⁴) | 25000 (2.5 · 10 ⁴) | 50000 (5 · 10 ⁴) | 100000 (10 ⁵) | 500000 (5 · 10 ⁵) | 1000000 (10 ⁶) | | | | |
| RR105 | 3.21 | 1220 | 1160 | 1140 | 1130 | 930 | 760 | 3500 | 1800 | 12 |
| | 4.10 | 1160 | 1070 | 1060 | 1050 | 900 | 730 | | | |
| | 5.42 | 1030 | 940 | 850 | 790 | 720 | 690 | | | |
| | 7.20 | 760 | 640 | 560 | 540 | 490 | 470 | | | |
| RR105D | 11.27 | 1220 | 1160 | 1140 | 1130 | 930 | 760 | 3500 | 1800 | 6 |
| | 14.39 | 1160 | 1070 | 1060 | 1050 | 900 | 730 | | | |
| | 19.07 | 1160 | 1070 | 1060 | 1050 | 900 | 730 | | | |
| | 25.46 | 1160 | 1070 | 1060 | 1050 | 900 | 730 | | | |
| | 33.66 | 1030 | 940 | 850 | 790 | 720 | 690 | | | |
| | 44.71 | 760 | 640 | 560 | 540 | 490 | 470 | | | |
| RR105T | 50.51 | 1160 | 1070 | 1060 | 1050 | 900 | 730 | 3500 | 1800 | 5 |
| | 66.92 | 1160 | 1070 | 1060 | 1050 | 900 | 730 | | | |
| | 89.37 | 1160 | 1070 | 1060 | 1050 | 900 | 730 | | | |
| | 118.39 | 1160 | 1070 | 1060 | 1050 | 900 | 730 | | | |
| | 158.11 | 1160 | 1070 | 1060 | 1050 | 900 | 730 | | | |
| | 209.02 | 1030 | 940 | 850 | 790 | 720 | 690 | | | |
| | 277.66 | 760 | 640 | 560 | 540 | 490 | 470 | | | |

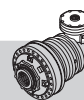

RA105 .. **i**



| | i | T ₂ [Nm] | | | | | | n _{1max} [min ⁻¹] | T _{2max} [Nm] | P _t [kW] |
|---------------|---------------|-----------------------------|-----------------------------------|---------------------------------|------------------------------|----------------------------------|-------------------------------|---|---------------------------|------------------------|
| | | n ₂ x h | | | | | | | | |
| | | 10000 (10 ⁴) | 25000 (2.5 · 10 ⁴) | 50000 (5 · 10 ⁴) | 100000 (10 ⁵) | 500000 (5 · 10 ⁵) | 1000000 (10 ⁶) | | | |
| RA105 | 1/... | | | | | | | | | |
| | 10.34 | 1220 | 1160 | 1140 | 1130 | 930 | 760 | 3500 | 1800 | 13 |
| | 13.20 | 1160 | 1070 | 1060 | 1050 | 900 | 730 | | | |
| | 17.45 | 1030 | 940 | 850 | 790 | 720 | 690 | | | |
| | 23.18 | 760 | 640 | 560 | 540 | 490 | 470 | | | |
| | 31.91 | 1030 | 890 | 840 | 790 | 700 | 660 | | | |
| | 42.39 | 760 | 640 | 560 | 540 | 490 | 470 | | | |
| RA105D | | | | | | | | | | |
| | 33.18 | 1220 | 1160 | 1140 | 1130 | 930 | 760 | 3500 | 1800 | 9 |
| | 42.38 | 1220 | 1160 | 1140 | 1130 | 930 | 760 | | | |
| | 54.13 | 1160 | 1070 | 1060 | 1050 | 900 | 730 | | | |
| | 71.55 | 1160 | 1070 | 1060 | 1050 | 900 | 730 | | | |
| | 95.05 | 1160 | 1070 | 1060 | 1050 | 900 | 730 | | | |
| | 125.66 | 1030 | 940 | 850 | 790 | 720 | 690 | | | |
| | 166.92 | 760 | 640 | 560 | 540 | 490 | 470 | | | |
| | 173.81 | 1160 | 1070 | 1060 | 1050 | 900 | 730 | | | |
| | 229.77 | 1030 | 940 | 850 | 790 | 720 | 690 | | | |
| | 305.23 | 760 | 640 | 560 | 540 | 490 | 470 | | | |



RR105 .. i ..

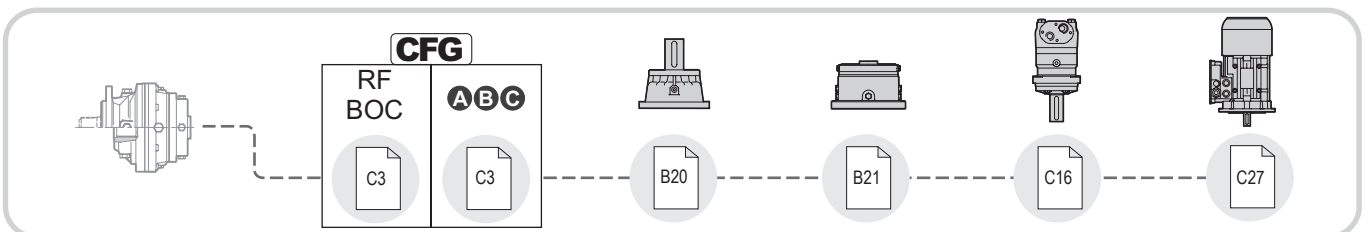
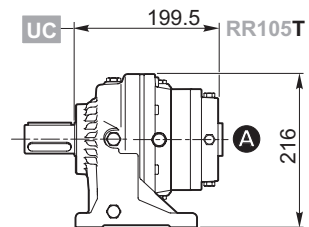
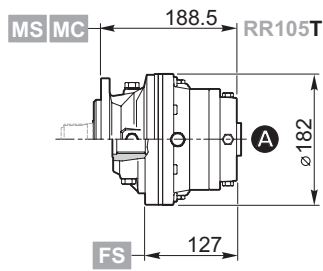
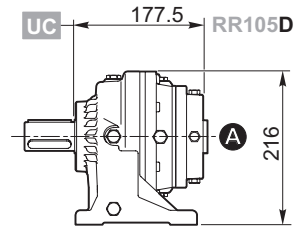
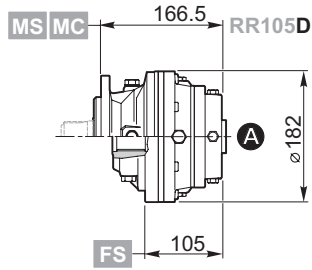
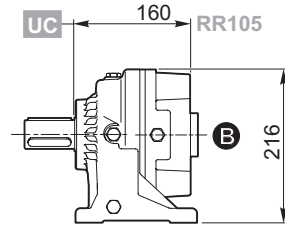
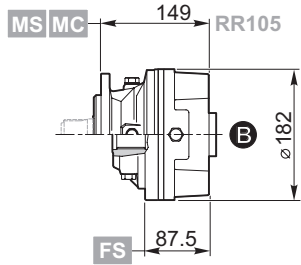

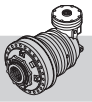

RA105 .. i ..

I

D

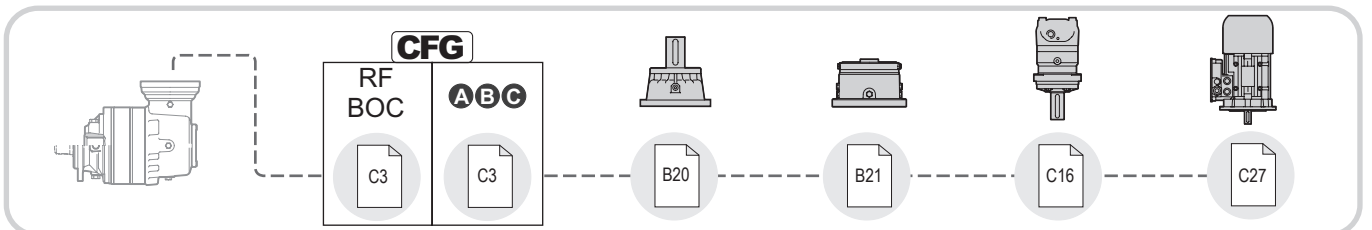
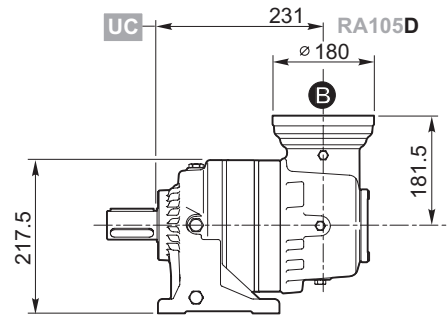
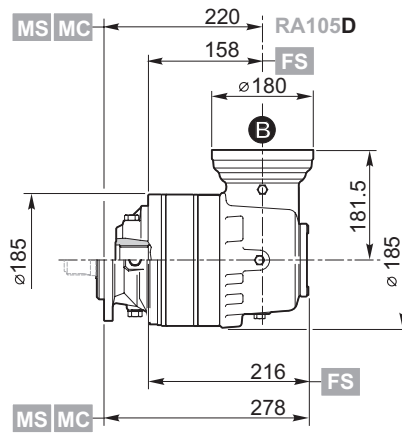
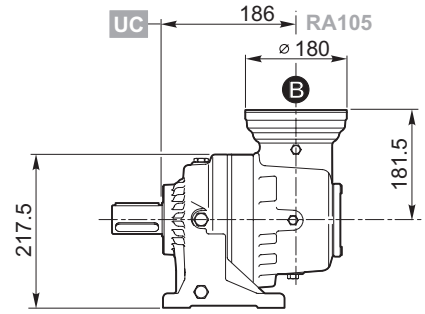
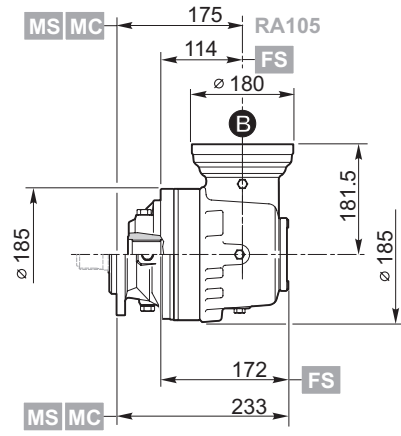

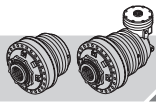

RR105
RA105

- MS
- MC
- UC

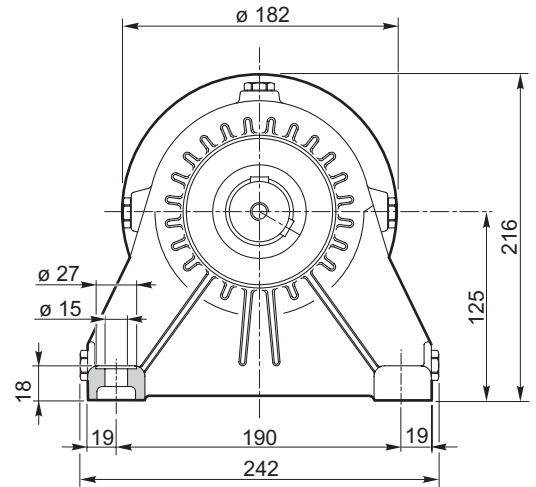
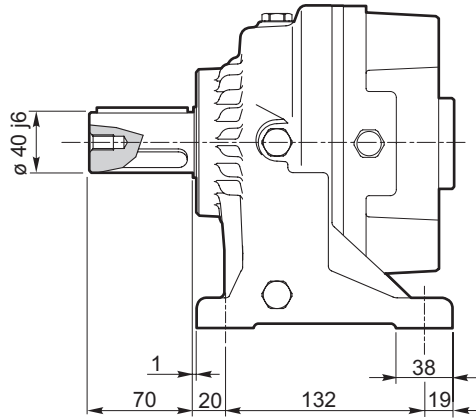
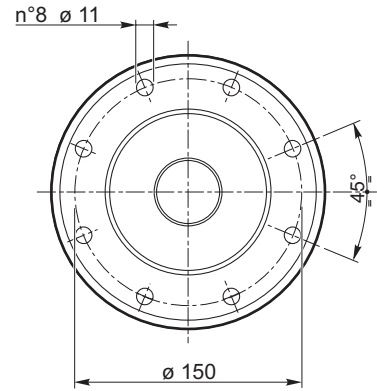
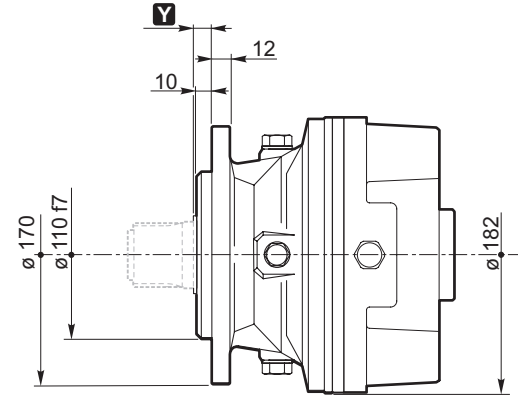

MS

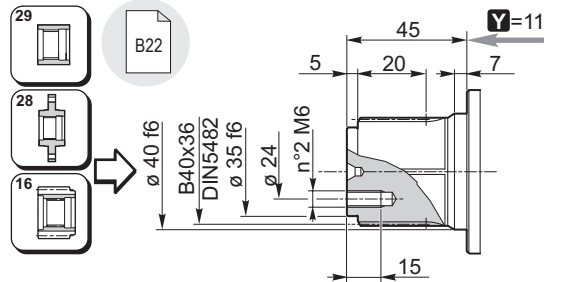
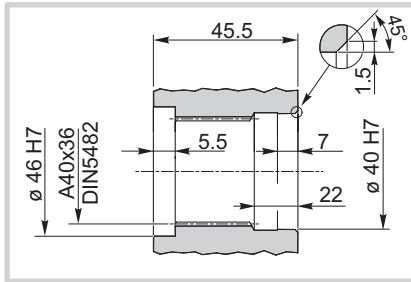
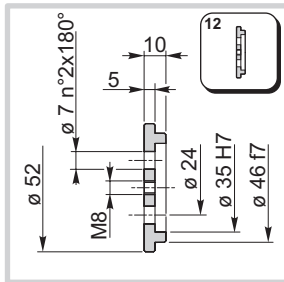

MC

UC

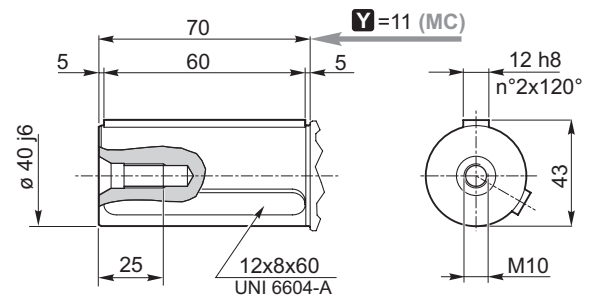
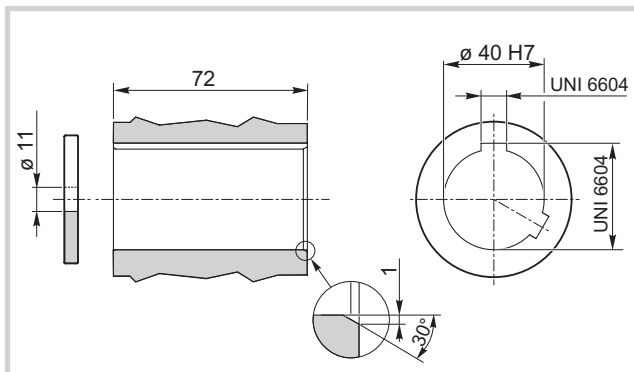

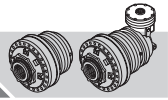

| | | | |
|-------|----|---|-----------|
| RR105 | .. | i | FS |
| RA105 | | | |

FS

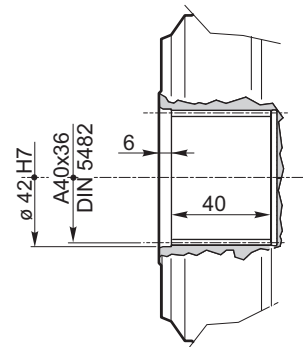
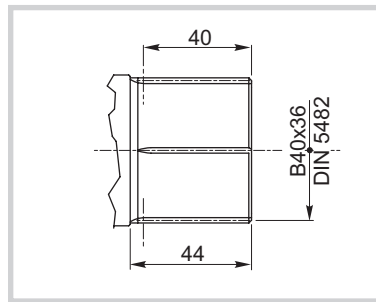
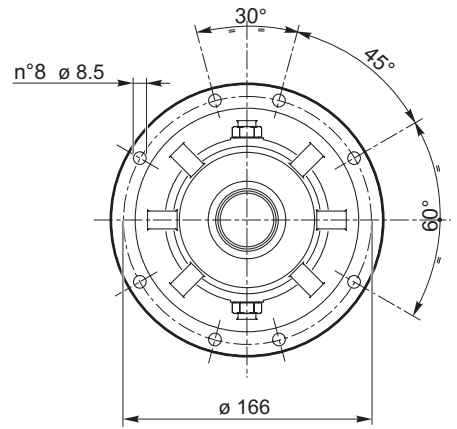
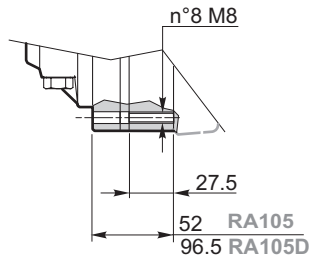
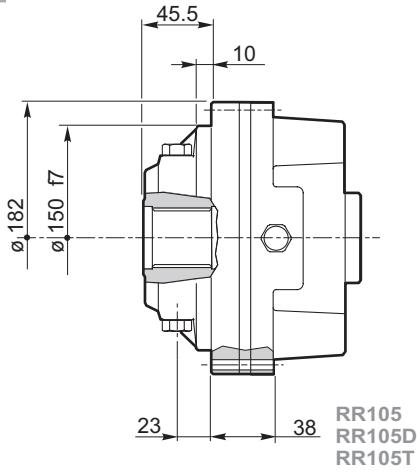

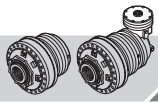

105

IT EN DE FR ES PT

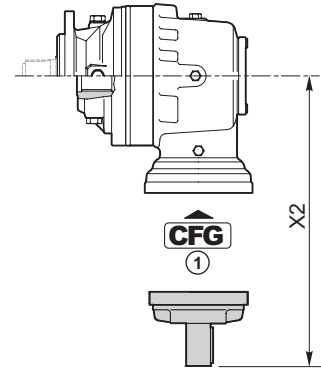
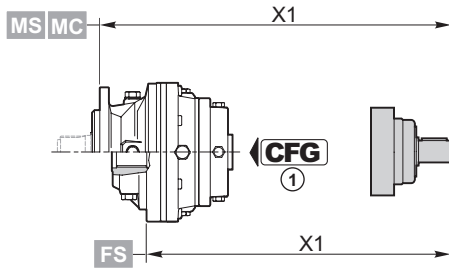
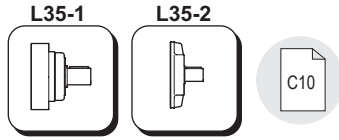

| | CFG ① | | code | X1 |
|---------------|-----------------|--------------|------------|--------------------------|
| RR105 | BOC | L35-2 | 154-2190M1 | 238.5 (M...) 177 (FS) |
| RR105D | RF | L35-1 | 154B4054 | 254.5 (M...) 193 (FS) |
| RR105T | RF | L35-1 | 154B4054M1 | 276.5 (M...) 215 (FS) |

| | CFG ① | | code | X2 |
|---------------|-----------------|--------------|------------|-------|
| RA105 | BOC | L35-2 | 154-2190M1 | 270.5 |
| RA105D | BOC | L35-2 | 154-2190M1 | 270.5 |

| CFG | |
|----------------------------------|--|
| RF BOC | |
| A B C | |

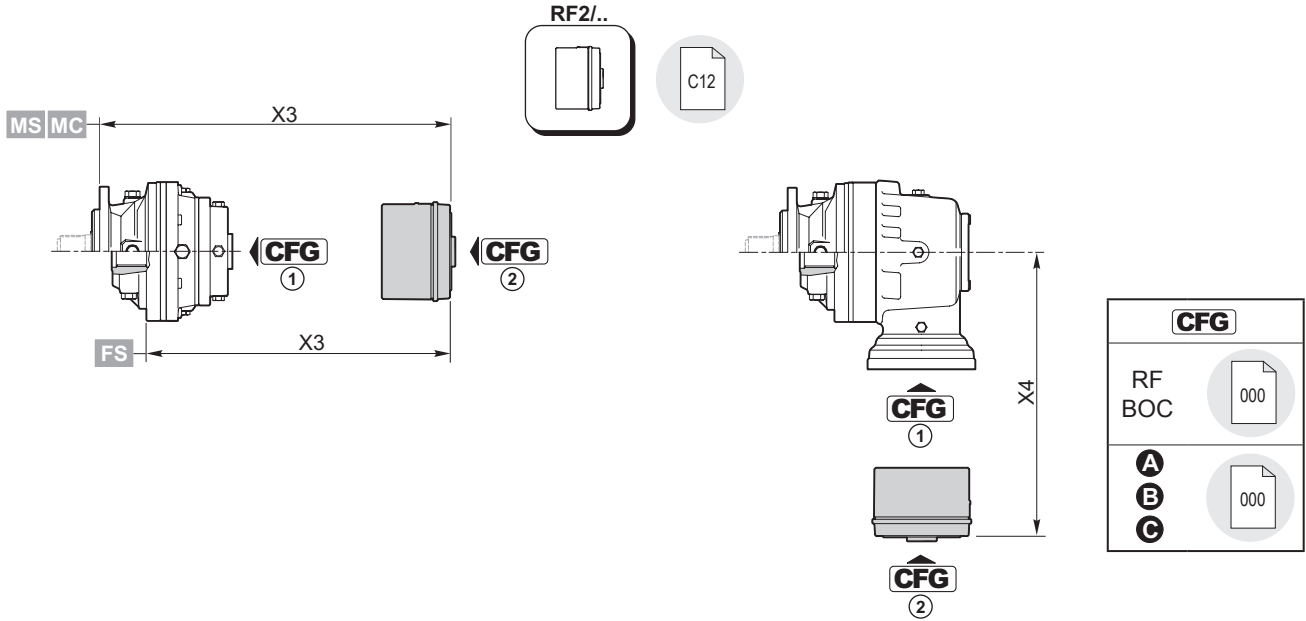
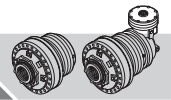

| RF2/.. | CFG ① | T _f [Nm] | CFG ② | | | | | | |
|--------|-------|---------------------|------------|--------------------------|-----------------------|------------------------|-----------------------|------------------------|--------------------------|
| | | | B | | OMP/OMR SAE A 2B Ø 25 | OMP/OMR SAE A 2B 1" 6B | OMP/OMR SAE A 4B Ø 25 | OMP/OMR SAE A 4B 1" 6B | X3 |
| | | | code | X3 | code | code | code | code | |
| RR105 | RF | 70 | 154-2838M1 | 187.5 (M...) 126 (FS) | 154-2863 | 154-2863M11 | 154-2635 | 154-2635M11 | 177.5 (M...) 116 (FS) |
| | | 140 | 154-2839M1 | | 154-2864 | 154-2864M11 | 154-2636 | 154-2636M11 | |
| | | 210 | 154-2840M1 | | 154-2865 | 154-2865M11 | 154-2637 | 154-2637M11 | |
| | | 320 | 154-2841M1 | | 154-2866 | 154-2866M11 | 154-2638 | 154-2638M11 | |
| | | 430 | 154-2842M1 | | 154-2867 | 154-2867M11 | 154-2639 | 154-2639M11 | |
| | | 600 | 154B8962M1 | | 154B9665 | 154B9665M11 | 154B9666 | 154B9666M11 | |

| | CFG ① | T _f [Nm] | CFG ② | | | | | | |
|--------|-------|---------------------|------------|--------------------------|-----------------------|------------------------|-----------------------|------------------------|--------------------------|
| | | | A | | OMP/OMR SAE A 2B Ø 25 | OMP/OMR SAE A 2B 1" 6B | OMP/OMR SAE A 4B Ø 25 | OMP/OMR SAE A 4B 1" 6B | X3 |
| | | | code | X3 | code | code | code | code | |
| RR105D | RF | 70 | 154-2832M1 | 232.5 (M...) 171 (FS) | 154-2858M1 | 154-2858M5 | | | 228 (M...) 166.5 (FS) |
| | | 140 | 154-2833M1 | | 154-2859M1 | 154-2859M5 | | | |
| | | 210 | 154-2834M1 | | 154-2860M1 | 154-2860M5 | | | |
| | | 320 | 154-2836M1 | | 154-2861M1 | 154-2861M5 | | | |
| | | 430 | 154-2837M1 | | 154-2862M1 | 154-2862M5 | | | |
| | | 600 | 154B8959M1 | | 154B9663M1 | 154B9663M5 | | | |
| RR105T | RF | 70 | 154-2832M3 | 254.5 (M...) 193 (FS) | 154-2858M3 | 154-2858M7 | | | 250 (M...) 188.5 (FS) |
| | | 140 | 154-2833M3 | | 154-2859M3 | 154-2859M7 | | | |
| | | 210 | 154-2834M3 | | 154-2860M3 | 154-2860M7 | | | |
| | | 320 | 154-2836M3 | | 154-2861M3 | 154-2861M7 | | | |
| | | 430 | 154-2837M3 | | 154-2862M3 | 154-2862M7 | | | |
| | | 600 | 154B8959M3 | | 154B9663M3 | 154B9663M7 | | | |

| | CFG ① | T _f [Nm] | CFG ② | | | | | | |
|--------|-------|---------------------|-------------|-------|-----------------------|------------------------|-----------------------|------------------------|-------|
| | | | B | | OMP/OMR SAE A 2B Ø 25 | OMP/OMR SAE A 2B 1" 6B | OMP/OMR SAE A 4B Ø 25 | OMP/OMR SAE A 4B 1" 6B | X4 |
| | | | code | X4 | code | code | code | code | |
| RA105 | RF | 70 | 154-2838M12 | 223.8 | 154-2863M12 | 154-2863M13 | 154-2635M12 | | 213.8 |
| | | 140 | 154-2839M12 | | 154-2864M12 | 154-2864M13 | 154-2636M12 | | |
| | | 210 | 154-2840M12 | | 154-2865M12 | 154-2865M13 | 154-2637M12 | | |
| | | 320 | 154-2841M12 | | 154-2866M12 | 154-2866M13 | 154-2638M12 | | |
| | | 430 | 154-2842M12 | | 154-2867M12 | 154-2867M13 | 154-2639M12 | | |
| | | 600 | 154B8962M12 | | 154B9665M12 | 154B9665M13 | 154B9666M12 | | |
| RA105D | RF | 70 | 154-2838M12 | 223.8 | 154-2863M12 | 154-2863M13 | 154-2635M12 | | 213.8 |
| | | 140 | 154-2839M12 | | 154-2864M12 | 154-2864M13 | 154-2636M12 | | |
| | | 210 | 154-2840M12 | | 154-2865M12 | 154-2865M13 | 154-2637M12 | | |
| | | 320 | 154-2841M12 | | 154-2866M12 | 154-2866M13 | 154-2638M12 | | |
| | | 430 | 154-2842M12 | | 154-2867M12 | 154-2867M13 | 154-2639M12 | | |
| | | 600 | 154B8962M12 | | 154B9665M12 | 154B9665M13 | 154B9666M12 | | |

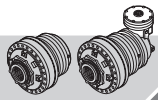

Kg 0.1

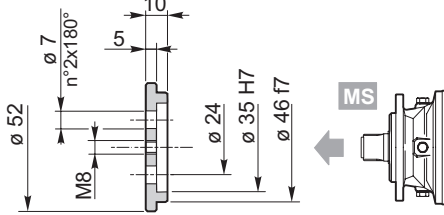

154-3063

Materiale / Material / Material / Matériau / Material / Material:
 Acciaio / Steel / Stahl / Acier / Acero / Aço
 C40 EN 10083-1 (1.1186)

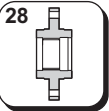

Kg 1.6

Materiale / Material / Material / Matériau / Material / Material: **Acciaio / Steel / Stahl / Acier / Acero / Aço EN 10083-1-C40 (1.1186)**

Trattamento termico:
 Tempra ad induzione secondo UNI 10932 su scanalato interno

Heat treatment:
 Induction hardening according to UNI 10932 on internal spline

Wärmebehandlung:
 Induktionshärtung nach UNI 10932 an interner Nut

Traitement thermique :
 Trempe par induction conformément à la norme UNI 10932 sur cannelé interne

Tratamiento térmico:
 Temple por inducción según UNI 10932 en acanalado interno

Tratamento térmico:
 Tempera por indução segundo UNI 10932 sobre ranhuras internas

154-3113

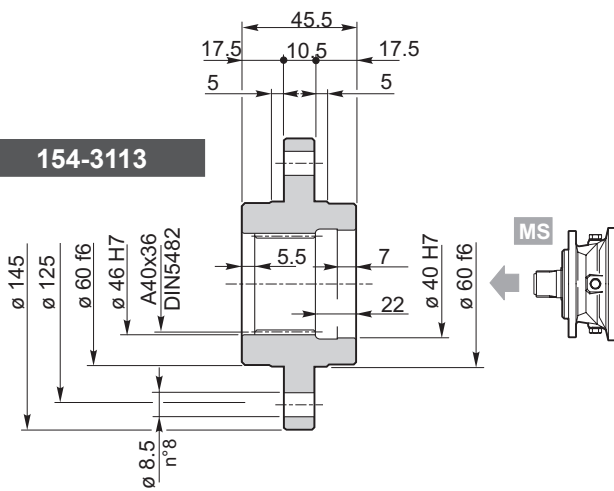

T_{2max} =
1740 Nm



Kg 0.5

Materiale / Material / Material / Matériau / Material / Material: **Acciaio / Steel / Stahl / Acier / Acero / Aço 39NiCrMo3 UNI 7845 (1.6511)**

Trattamento termico:
 Tempra ad induzione secondo UNI 10932 su scanalato interno

Heat treatment:
 Induction hardening according to UNI 10932 on internal spline

Wärmebehandlung:
 Induktionshärtung nach UNI 10932 an interner Nut

Traitement thermique :
 Trempe par induction conformément à la norme UNI 10932 sur cannelé interne

Tratamiento térmico:
 Temple por inducción según UNI 10932 en acanalado interno

Tratamento térmico:
 Tempera por indução segundo UNI 10932 sobre ranhuras internas

154-3094

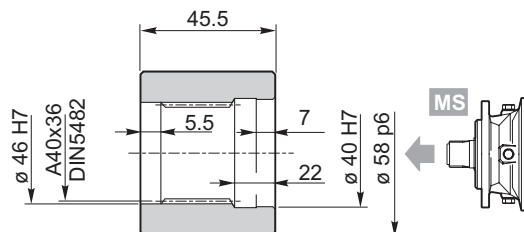

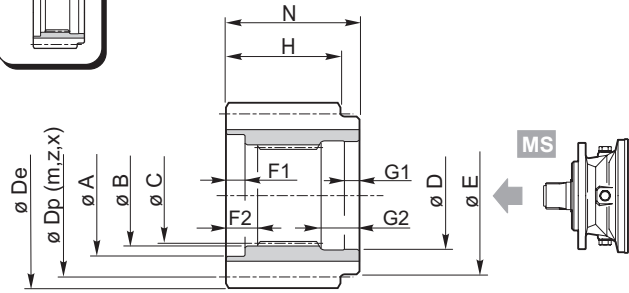
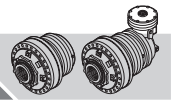

Materiale / Material / Material
 Matériau / Material / Material
 Acciaio / Steel / Stahl / Acier / Acero / Aço
 39NiCrMo3 UNI 7845 (1.6511)

Trattamento termico:
 Tempra ad induzione secondo UNI 10932 su scanalato interno

Heat treatment:
 Induction hardening according to UNI 10932 on internal spline

Wärmebehandlung:
 Induktionshärtung nach UNI 10932 an interner Nut

Traitement thermique :
 Trempe par induction conformément à la norme UNI 10932 sur cannelé interne

Tratamiento térmico:
 Temple por inducción según UNI 10932 en acanalado interno

Tratamento térmico:
 Tempera por indução segundo UNI 10932 sobre ranhuras internas

| | A | B | C | D | E | F1 | F2 | G1 | G2 | N | m | z | x | H | Dp | De | Code |
|----|----|-------|-------------------|-------|----|----|-----|----|----|------|---|----|------|------|-----|------|----------|
| MS | 53 | 46 F6 | DIN5482 A40x36 | 40 F6 | 50 | 2 | 7.5 | 7 | 21 | 47.5 | 4 | 15 | 0.5 | 44.5 | 60 | 69.8 | 154-3072 |
| | 53 | 46 F6 | DIN5482 A40x36 | 40 F6 | 50 | 2 | 7.5 | 7 | 21 | 47.5 | 4 | 32 | 0 | 44.5 | 128 | 135 | 154-3104 |
| | 53 | 46 F6 | DIN5482 A40x36 | 40 F6 | 50 | 2 | 7.5 | 7 | 21 | 47.5 | 6 | 12 | 0.25 | 44.5 | 72 | 84.8 | 154-3073 |
| | 53 | 46 F6 | DIN5482 A40x36 | 40 F6 | 50 | 2 | 7.5 | 7 | 21 | 47.5 | 5 | 14 | 0.5 | 44.5 | 70 | 84 | 154-2709 |
| | 53 | 46 F6 | DIN5482 A40x36 | 40 F6 | 50 | 2 | 7.5 | 7 | 21 | 47.5 | 6 | 24 | 0 | 44.5 | 144 | 154 | 154-2285 |
| | 53 | 46 F6 | DIN5482 A40x36 | 40 F6 | 50 | 2 | 7.5 | 7 | 21 | 47.5 | 8 | 16 | 0.25 | 44.5 | 128 | 145 | 154-2707 |

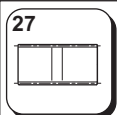

Kg 0.9

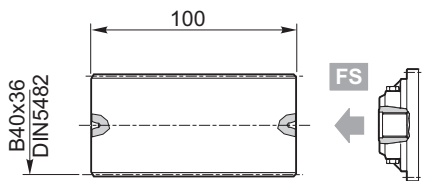

154-3050

Materiale / Materiale / Material
 Matériau / Material / Material:
 Acciaio / Steel / Stahl / Acier / Acero / Aço
 39NiCrMo3 UNI 7845 (1.6511)

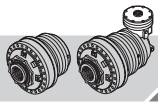

| | | | |
|----|-----|----|----|
| RR | 105 | .. | MS |
| RA | | | MC |

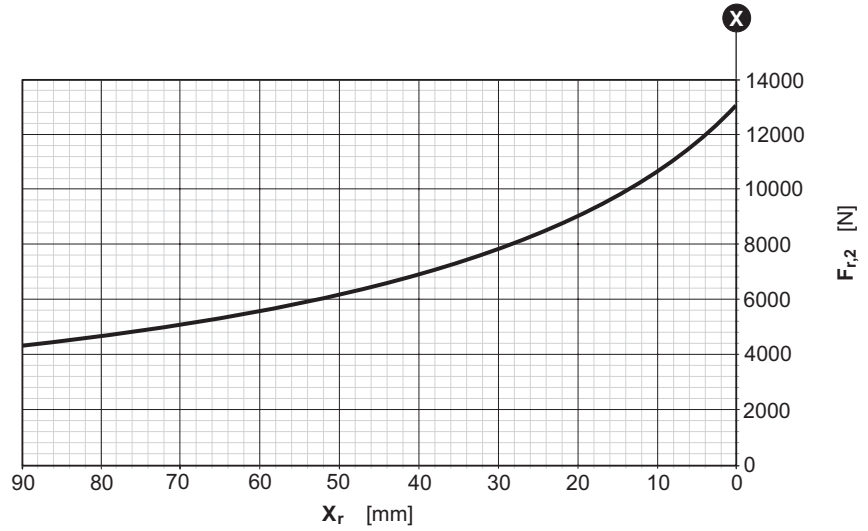
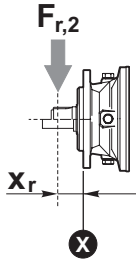

| | | | |
|----|-----|----|----|
| RR | 105 | .. | UC |
| RA | | | |

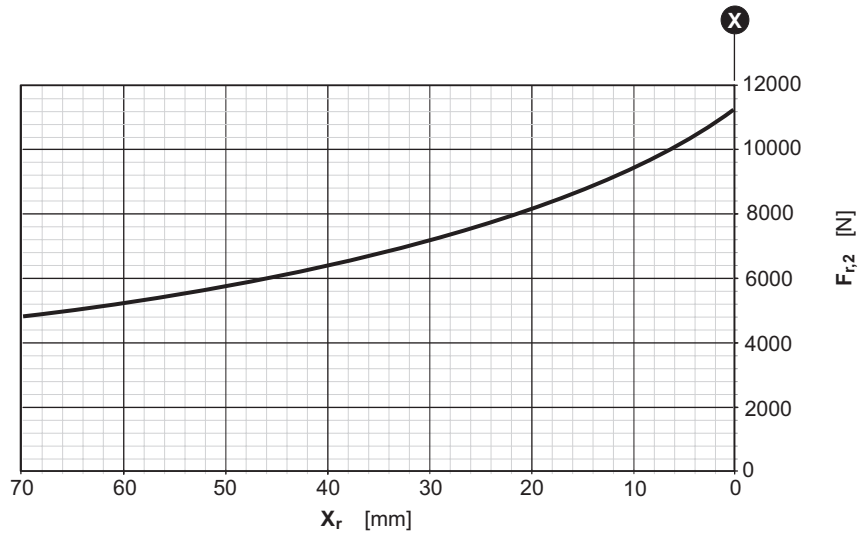
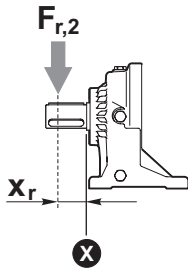

Fattore correttivo $k_{r,2}$ / $k_{r,2}$ Corrective coefficient / Korrekturfaktor $k_{r,2}$
 Facteur correctif $k_{r,2}$ / Factor de corrección $k_{r,2}$ / Fator corretivo $k_{r,2}$

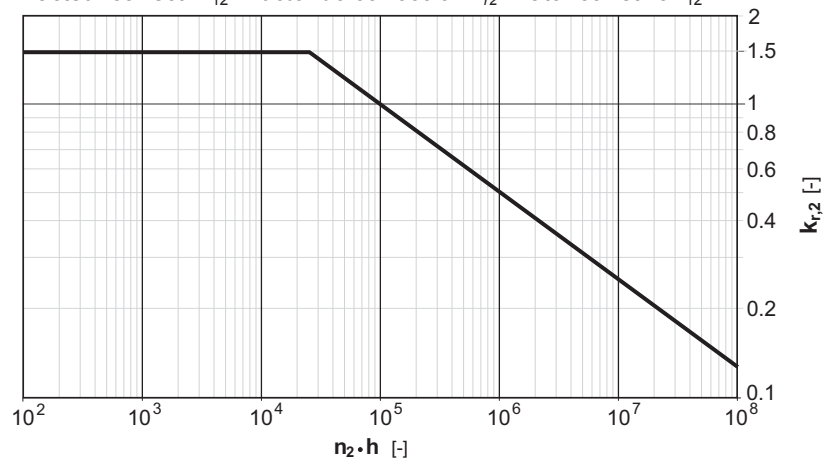

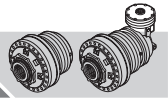



RR110 .. **i**



| | i 1/... | T ₂ [Nm] | | | | | | n _{1max} [min ⁻¹] | T _{2max} [Nm] | P _t [kW] |
|---------------|---------------|-----------------------------|-----------------------------------|---------------------------------|------------------------------|----------------------------------|-------------------------------|---|---------------------------|------------------------|
| | | n ₂ x h | | | | | | | | |
| | | 10000 (10 ⁴) | 25000 (2.5 · 10 ⁴) | 50000 (5 · 10 ⁴) | 100000 (10 ⁵) | 500000 (5 · 10 ⁵) | 1000000 (10 ⁶) | | | |
| RR110 | 3.31 | 1540 | 1460 | 1440 | 1340 | 1020 | 820 | 3500 | 2000 | 12 |
| | 3.91 | 1520 | 1410 | 1300 | 1150 | 1000 | 810 | | | |
| | 4.94 | 1360 | 1140 | 1000 | 920 | 830 | 790 | | | |
| | 5.78 | 1250 | 1050 | 920 | 870 | 790 | 750 | | | |
| | 7.09 | 850 | 710 | 630 | 610 | 550 | 530 | | | |
| RR110D | 11.62 | 1540 | 1460 | 1440 | 1340 | 1020 | 820 | 3500 | 2000 | 6 |
| | 13.72 | 1520 | 1410 | 1300 | 1150 | 1000 | 810 | | | |
| | 18.18 | 1520 | 1410 | 1300 | 1150 | 1000 | 810 | | | |
| | 22.97 | 1360 | 1140 | 1000 | 920 | 830 | 790 | | | |
| | 26.88 | 1250 | 1050 | 920 | 870 | 790 | 750 | | | |
| | 30.68 | 1360 | 1140 | 1000 | 920 | 830 | 790 | | | |
| | 35.89 | 1250 | 1050 | 920 | 870 | 790 | 750 | | | |
| | 44.03 | 850 | 710 | 630 | 610 | 550 | 530 | | | |
| | RR110T | 48.17 | 1520 | 1410 | 1300 | 1150 | 1000 | | | |
| 63.82 | | 1520 | 1410 | 1300 | 1150 | 1000 | 810 | | | |
| 84.54 | | 1520 | 1410 | 1300 | 1150 | 1000 | 810 | | | |
| 106.82 | | 1360 | 1140 | 1000 | 920 | 830 | 790 | | | |
| 124.98 | | 1250 | 1050 | 920 | 870 | 790 | 750 | | | |
| 142.65 | | 1360 | 1140 | 1000 | 920 | 830 | 790 | | | |
| 166.91 | | 1250 | 1050 | 920 | 870 | 790 | 750 | | | |
| 222.9 | | 1250 | 1050 | 920 | 870 | 790 | 750 | | | |
| 273.42 | | 850 | 710 | 630 | 610 | 550 | 530 | | | |



RA110

..

i



| i | T ₂ [Nm] | | | | | | n _{1max} [min ⁻¹] | T _{2max} [Nm] | P _t [kW] |
|---------------|-----------------------------|-----------------------------------|---------------------------------|------------------------------|----------------------------------|-------------------------------|---|---------------------------|------------------------|
| | n ₂ x h | | | | | | | | |
| 1/... | 10000 (10 ⁴) | 25000 (2.5 · 10 ⁴) | 50000 (5 · 10 ⁴) | 100000 (10 ⁵) | 500000 (5 · 10 ⁵) | 1000000 (10 ⁶) | | | |
| RA110 | 10.66 | 1540 | 1460 | 1440 | 1310 | 1020 | 3500 | 2000 | 13 |
| | 12.59 | 1520 | 1410 | 1300 | 1150 | 1000 | | | |
| | 15.91 | 1360 | 1140 | 1000 | 920 | 830 | | | |
| | 18.61 | 1250 | 1050 | 920 | 870 | 790 | | | |
| | 22.83 | 850 | 710 | 630 | 610 | 550 | | | |
| | 29.09 | 1000 | 830 | 770 | 730 | 640 | | | |
| | 34.03 | 1140 | 940 | 890 | 840 | 740 | | | |
| | 41.75 | 850 | 710 | 630 | 610 | 550 | | | |
| RA110D | 35.28 | 1540 | 1460 | 1440 | 1340 | 1020 | 3500 | 2000 | 9 |
| | 41.67 | 1540 | 1460 | 1440 | 1340 | 1020 | | | |
| | 52.65 | 1540 | 1460 | 1440 | 1340 | 1020 | | | |
| | 72.77 | 1520 | 1410 | 1300 | 1150 | 1000 | | | |
| | 89.26 | 1520 | 1410 | 1300 | 1150 | 1000 | | | |
| | 112.78 | 1360 | 1140 | 1000 | 920 | 830 | | | |
| | 131.96 | 1250 | 1050 | 920 | 870 | 790 | | | |
| | 161.86 | 850 | 710 | 630 | 610 | 550 | | | |
| | 196.71 | 1250 | 1050 | 920 | 870 | 790 | | | |
| | 206.22 | 1360 | 1140 | 1000 | 920 | 830 | | | |
| | 241.29 | 1250 | 1050 | 920 | 870 | 790 | | | |
| | 295.98 | 850 | 710 | 630 | 610 | 550 | | | |



RR110 .. i ..

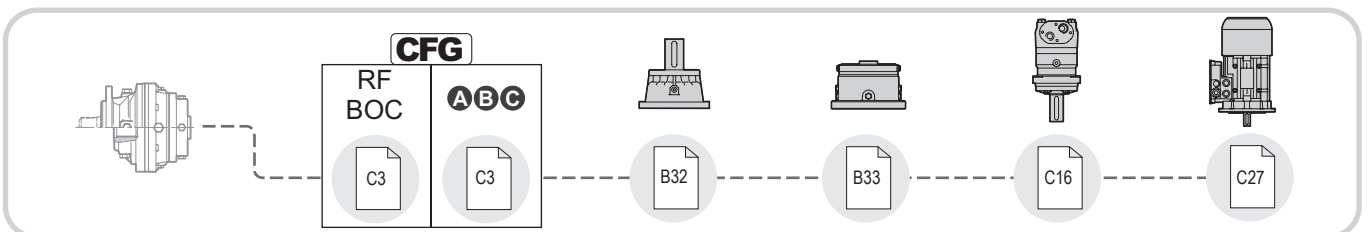
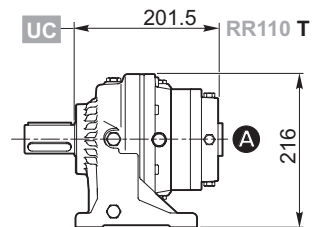
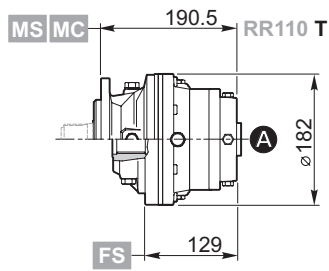
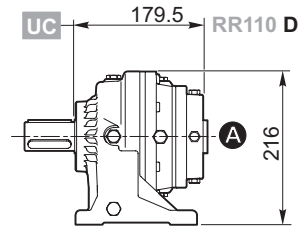
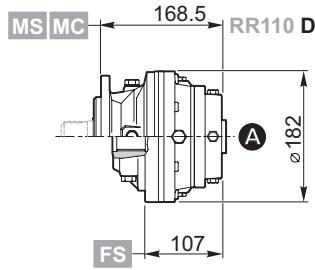
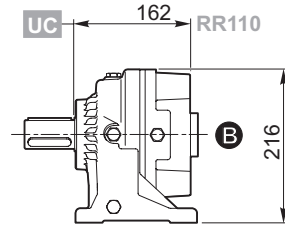
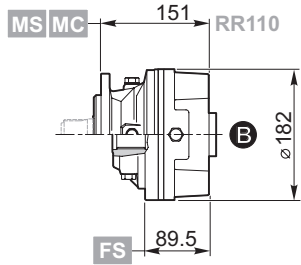

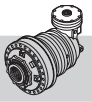

RA110 .. i ..

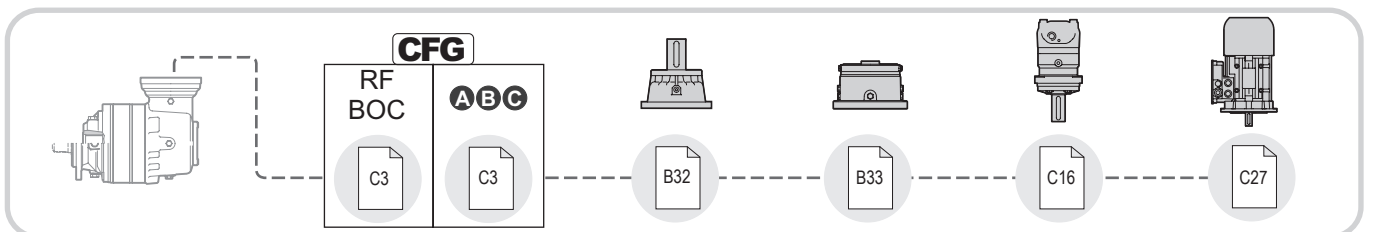
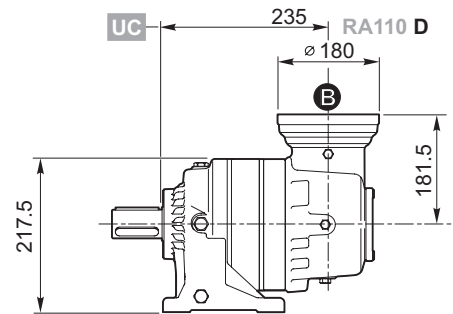
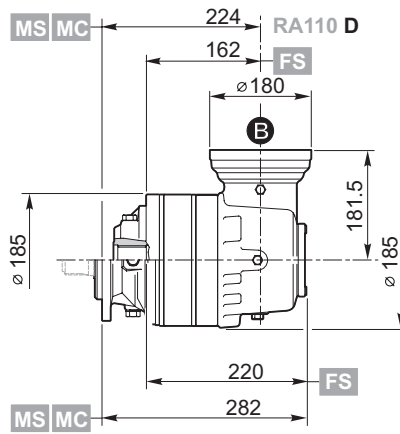
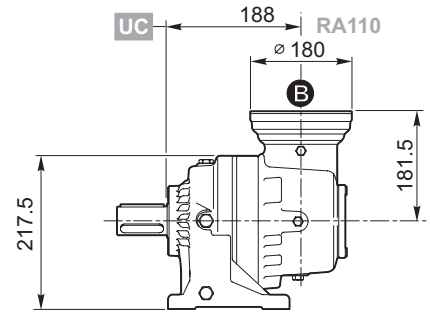
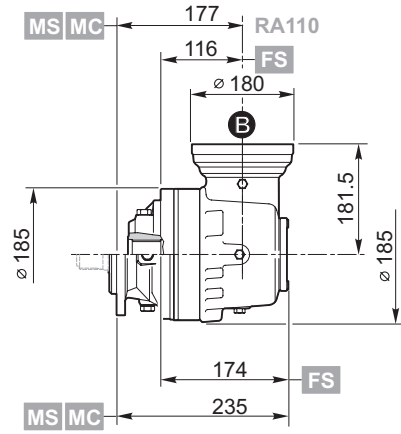
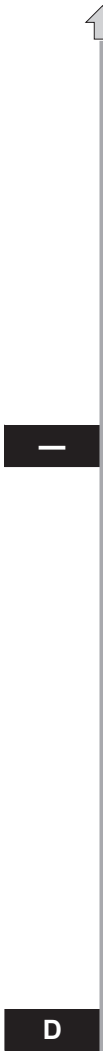

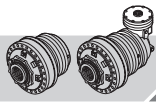

110

IT EN DEFRES PT

RR110
RA110

MS

MC

UC

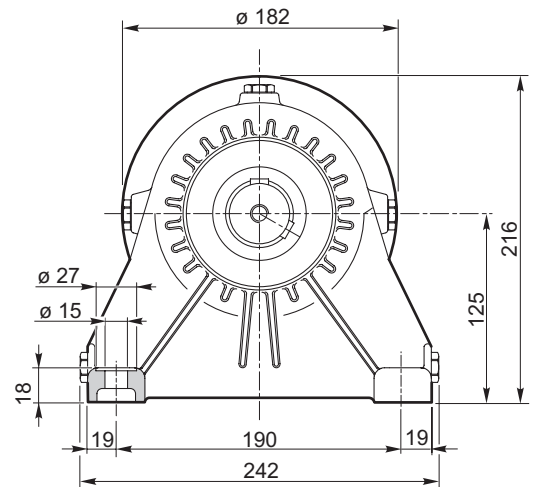
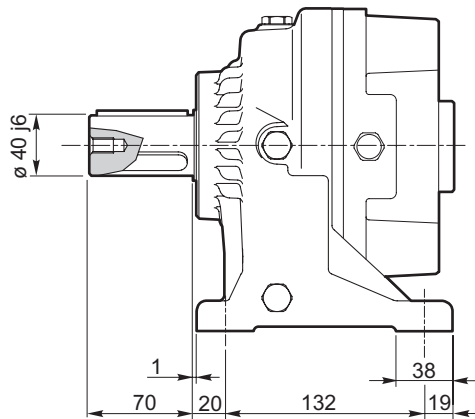
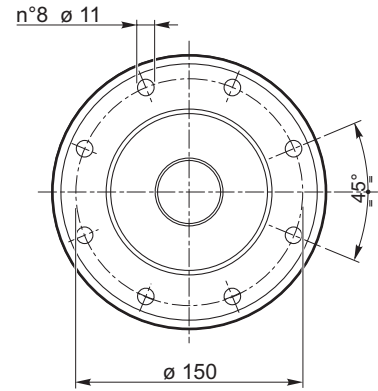
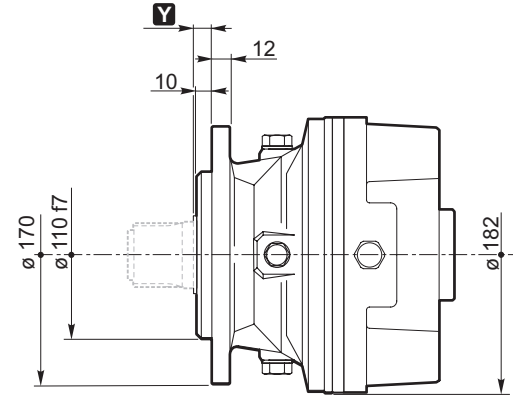

MS

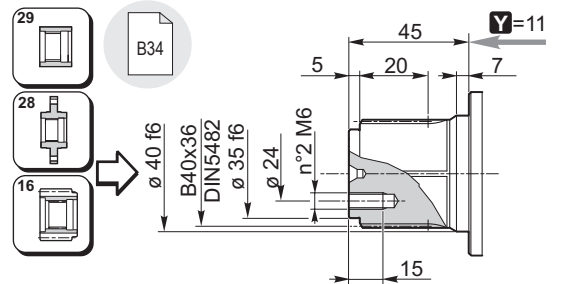
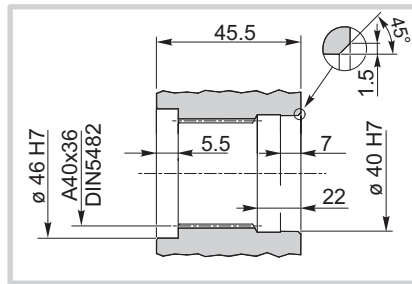
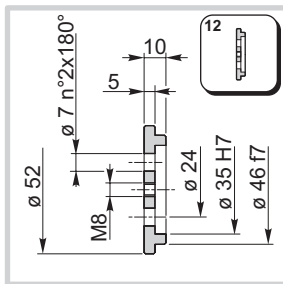

MC

UC

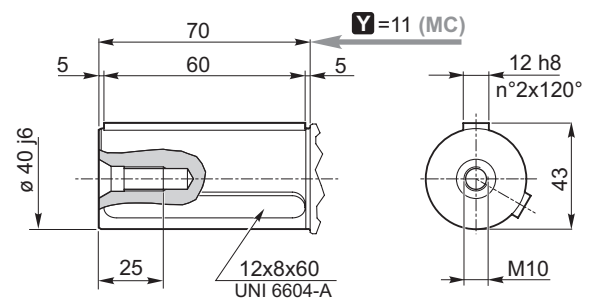
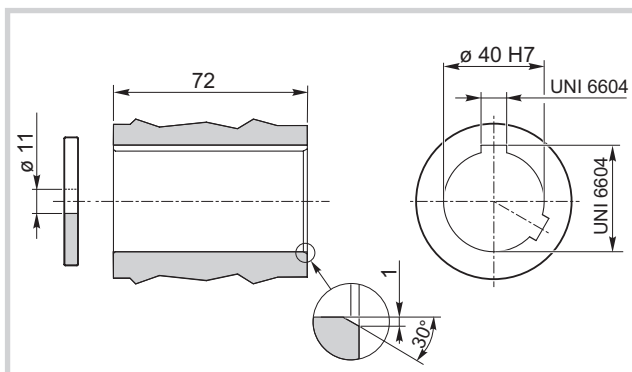

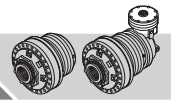

| | | | |
|-------|----|---|----|
| RR110 | .. | i | FS |
| RA110 | | | |

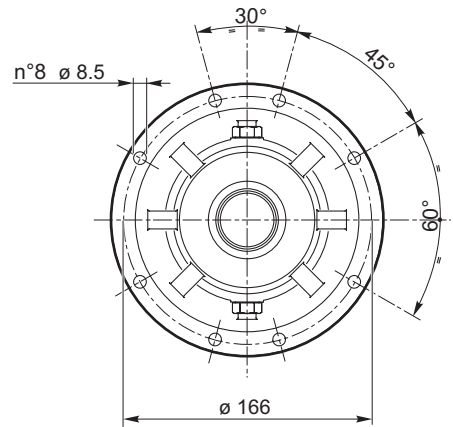
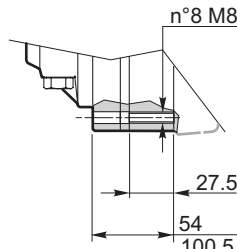
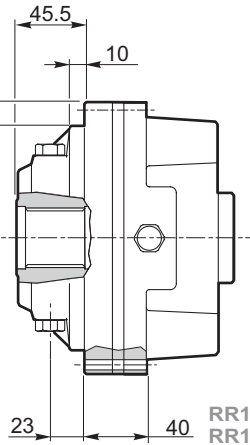
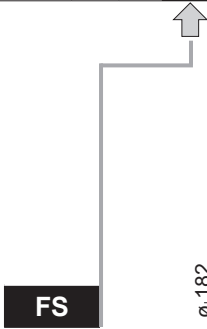

RR110
RR110D
RR110T

RA110
100.5 RA110D

Trattamento termico:
Tempra ad induzione secondo UNI 10932 su scanalato interno

Heat treatment:
Induction hardening according to UNI 10932 on internal spline

Wärmebehandlung:
Induktionshärtung nach UNI 10932 an interner Nut

Traitement thermique:
Trempe par induction conformément à la norme UNI 10932 sur cannelé interne

Tratamiento térmico:
Temple por inducción según UNI 10932 en acanalado interno

Tratamento térmico:
Tempera por indução segundo UNI 10932 sobre ranhuras internas

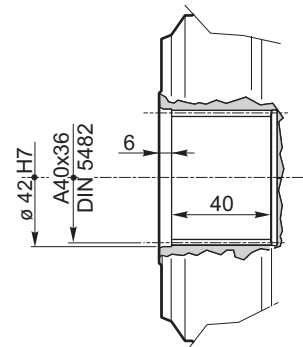
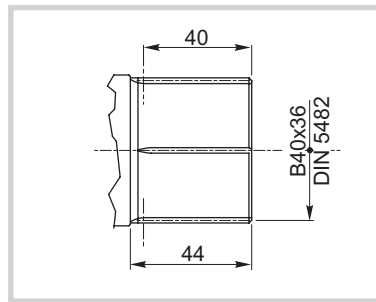

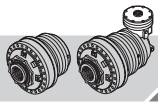

110

IT EN DE FR ES PT

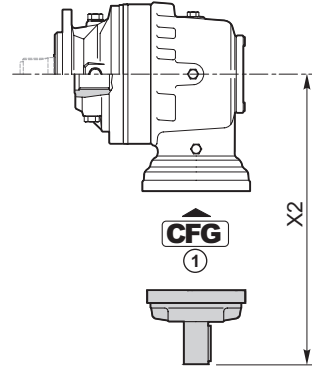
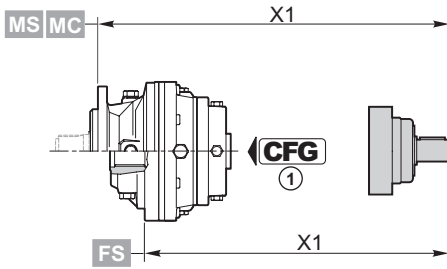
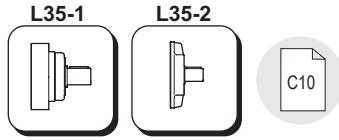

| | CFG ① | | code | X1 |
|---------------|-----------------|--------------|------------|--------------------------|
| RR110 | BOC | L35-2 | 154-2190M1 | 240.5 (M...) 179 (FS) |
| RR110D | RF | L35-1 | 154B4054 | 256.5 (M...) 195 (FS) |
| RR110T | RF | L35-1 | 154B4054M1 | 278.5 (M...) 217 (FS) |

| | CFG ① | | code | X2 |
|---------------|-----------------|--------------|------------|-------|
| RA110 | BOC | L35-2 | 154-2190M1 | 270.5 |
| RA110D | BOC | L35-2 | 154-2190M1 | 270.5 |

| CFG | |
|----------------------------------|--|
| RF BOC | |
| A B C | |

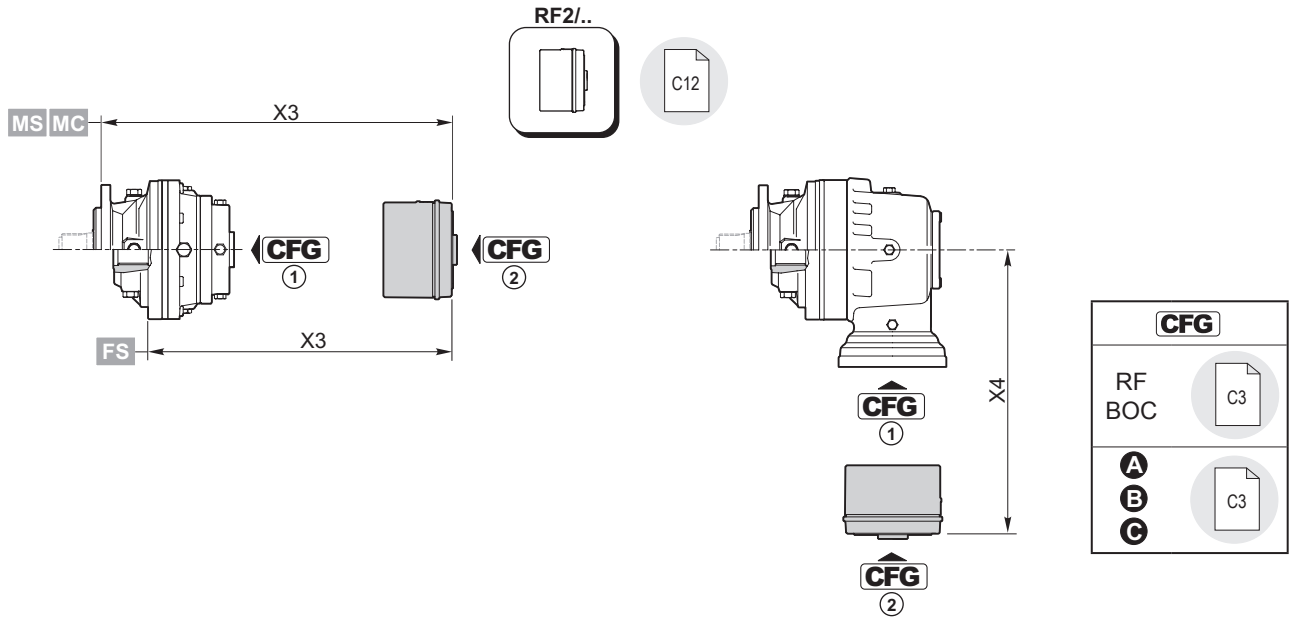
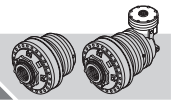

| RF2../ | CFG ① | T _f [Nm] | CFG ② | | | | | | |
|--------|-------|---------------------|------------|--------------------------|-----------------------|------------------------|-----------------------|------------------------|--------------------------|
| | | | B | | OMP/OMR SAE A 2B Ø 25 | OMP/OMR SAE A 2B 1" 6B | OMP/OMR SAE A 4B Ø 25 | OMP/OMR SAE A 4B 1" 6B | X3 |
| | | | code | X3 | code | code | code | code | |
| RR110 | RF | 70 | 154-2838M1 | 189.5 (M...) 128 (FS) | 154-2863 | 154-2863M11 | 154-2635 | 154-2635M11 | 179.5 (M...) 118 (FS) |
| | | 140 | 154-2839M1 | | 154-2864 | 154-2864M11 | 154-2636 | 154-2636M11 | |
| | | 210 | 154-2840M1 | | 154-2865 | 154-2865M11 | 154-2637 | 154-2637M11 | |
| | | 320 | 154-2841M1 | | 154-2866 | 154-2866M11 | 154-2638 | 154-2638M11 | |
| | | 430 | 154-2842M1 | | 154-2867 | 154-2867M11 | 154-2639 | 154-2639M11 | |
| | | 600 | 154B8962M1 | | 154B9665 | 154B9665M11 | 154B9666 | 154B9666M11 | |

| | CFG ① | T _f [Nm] | CFG ② | | | | | | |
|--------|-------|---------------------|------------|--------------------------|-----------------------|------------------------|-----------------------|------------------------|--------------------------|
| | | | A | | OMP/OMR SAE A 2B Ø 25 | OMP/OMR SAE A 2B 1" 6B | OMP/OMR SAE A 4B Ø 25 | OMP/OMR SAE A 4B 1" 6B | X3 |
| | | | code | X3 | code | code | code | code | |
| RR110D | RF | 70 | 154-2832M1 | 234.5 (M...) 173 (FS) | 154-2858M1 | 154-2858M5 | | | 230 (M...) 168.5 (FS) |
| | | 140 | 154-2833M1 | | 154-2859M1 | 154-2859M5 | | | |
| | | 210 | 154-2834M1 | | 154-2860M1 | 154-2860M5 | | | |
| | | 320 | 154-2836M1 | | 154-2861M1 | 154-2861M5 | | | |
| | | 430 | 154-2837M1 | | 154-2862M1 | 154-2862M5 | | | |
| | | 600 | 154B8959M1 | | 154B9663M1 | 154B9663M5 | | | |
| RR110T | RF | 70 | 154-2832M3 | 256.5 (M...) 195 (FS) | 154-2858M3 | 154-2858M7 | | | 252 (M...) 190.5 (FS) |
| | | 140 | 154-2833M3 | | 154-2859M3 | 154-2859M7 | | | |
| | | 210 | 154-2834M3 | | 154-2860M3 | 154-2860M7 | | | |
| | | 320 | 154-2836M3 | | 154-2861M3 | 154-2861M7 | | | |
| | | 430 | 154-2837M3 | | 154-2862M3 | 154-2862M7 | | | |
| | | 600 | 154B8959M3 | | 154B9663M3 | 154B9663M7 | | | |

| | CFG ① | T _f [Nm] | CFG ② | | | | | | |
|--------|-------|---------------------|-------------|-------|-----------------------|------------------------|-----------------------|------------------------|-------|
| | | | B | | OMP/OMR SAE A 2B Ø 25 | OMP/OMR SAE A 2B 1" 6B | OMP/OMR SAE A 4B Ø 25 | OMP/OMR SAE A 4B 1" 6B | X4 |
| | | | code | X4 | code | code | code | code | |
| RA110 | RF | 70 | 154-2838M12 | 223.8 | 154-2863M12 | 154-2863M13 | 154-2635M12 | | 213.8 |
| | | 140 | 154-2839M12 | | 154-2864M12 | 154-2864M13 | 154-2636M12 | | |
| | | 210 | 154-2840M12 | | 154-2865M12 | 154-2865M13 | 154-2637M12 | | |
| | | 320 | 154-2841M12 | | 154-2866M12 | 154-2866M13 | 154-2638M12 | | |
| | | 430 | 154-2842M12 | | 154-2867M12 | 154-2867M13 | 154-2639M12 | | |
| | | 600 | 154B8962M12 | | 154B9665M12 | 154B9665M13 | 154B9666M12 | | |
| RA110D | RF | 70 | 154-2838M12 | 223.8 | 154-2863M12 | 154-2863M13 | 154-2635M12 | | 213.8 |
| | | 140 | 154-2839M12 | | 154-2864M12 | 154-2864M13 | 154-2636M12 | | |
| | | 210 | 154-2840M12 | | 154-2865M12 | 154-2865M13 | 154-2637M12 | | |
| | | 320 | 154-2841M12 | | 154-2866M12 | 154-2866M13 | 154-2638M12 | | |
| | | 430 | 154-2842M12 | | 154-2867M12 | 154-2867M13 | 154-2639M12 | | |
| | | 600 | 154B8962M12 | | 154B9665M12 | 154B9665M13 | 154B9666M12 | | |

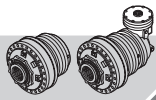

12
Kg 0.1

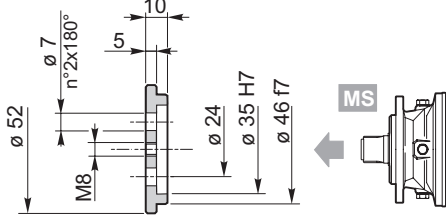

154-3063

Materiale / Material / Material / Matériau / Material / Material:
Acciaio / Steel / Stahl / Acier / Acero / Aço
C40 EN 10083-1 (1.1186)

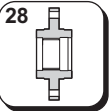

28
Kg 1.6

Materiale / Material / Material / Matériau / Material / Material: **Acciaio / Steel / Stahl / Acier / Acero / Aço EN 10083-1-C40 (1.1186)**

Trattamento termico:
 Tempra ad induzione secondo UNI 10932 su scanalato interno

Heat treatment:
 Induction hardening according to UNI 10932 on internal spline

Wärmebehandlung:
 Induktionshärtung nach UNI 10932 an interner Nut

Traitement thermique :
 Trempe par induction conformément à la norme UNI 10932 sur cannelé interne

Tratamiento térmico:
 Temple por inducción según UNI 10932 en acanalado interno

Tratamento térmico:
 Tempra por indução segundo UNI 10932 sobre ranhuras internas

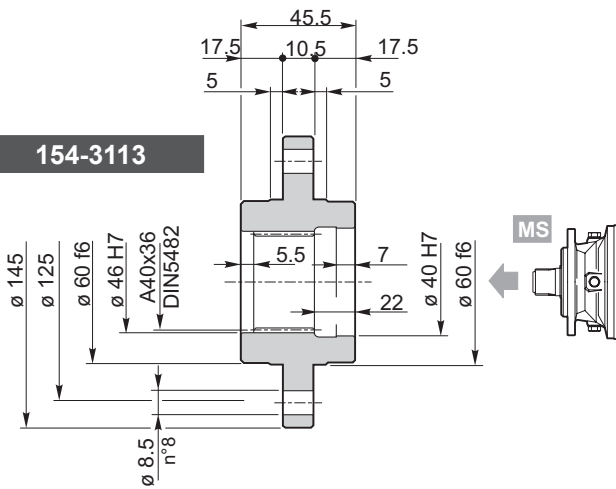

154-3113

T_{2max} =
1740 Nm



29
Kg 0.5

Materiale / Material / Material / Matériau / Material / Material: **Acciaio / Steel / Stahl / Acier / Acero / Aço 39NiCrMo3 UNI 7845 (1.6511)**

Trattamento termico:
 Tempra ad induzione secondo UNI 10932 su scanalato interno

Heat treatment:
 Induction hardening according to UNI 10932 on internal spline

Wärmebehandlung:
 Induktionshärtung nach UNI 10932 an interner Nut

Traitement thermique :
 Trempe par induction conformément à la norme UNI 10932 sur cannelé interne

Tratamiento térmico:
 Temple por inducción según UNI 10932 en acanalado interno

Tratamento térmico:
 Tempra por indução segundo UNI 10932 sobre ranhuras internas

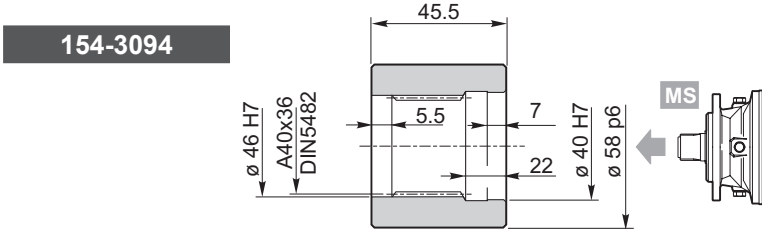

154-3094

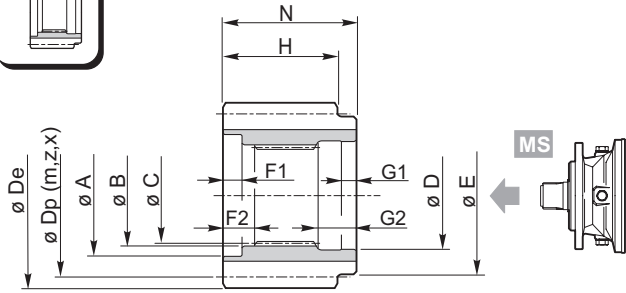
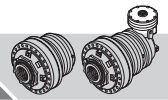

Materiale / Material / Material
 Matériau / Material / Material
 Acciaio / Steel / Stahl / Acier / Acero / Aço
39NiCrMo3 UNI 7845 (1.6511)

Trattamento termico:
 Tempra ad induzione secondo UNI 10932 su scanalato interno

Heat treatment:
 Induction hardening according to UNI 10932 on internal spline

Wärmebehandlung:
 Induktionshärtung nach UNI 10932 an interner Nut

Traitement thermique:
 Trempe par induction conformément à la norme UNI 10932 sur cannelé interne

Tratamiento térmico:
 Temple por inducción según UNI 10932 en acanalado interno

Tratamento térmico:
 Tempera por indução segundo UNI 10932 sobre ranhuras internas

| | A | B | C | D | E | F1 | F2 | G1 | G2 | N | m | z | x | H | Dp | De | Code |
|----|----|-------|-------------------|-------|----|----|-----|----|----|------|---|----|------|------|-----|------|----------|
| MS | 53 | 46 F6 | DIN5482 A40x36 | 40 F6 | 50 | 2 | 7.5 | 7 | 21 | 47.5 | 4 | 15 | 0.5 | 44.5 | 60 | 69.8 | 154-3072 |
| | 53 | 46 F6 | DIN5482 A40x36 | 40 F6 | 50 | 2 | 7.5 | 7 | 21 | 47.5 | 4 | 32 | 0 | 44.5 | 128 | 135 | 154-3104 |
| | 53 | 46 F6 | DIN5482 A40x36 | 40 F6 | 50 | 2 | 7.5 | 7 | 21 | 47.5 | 6 | 12 | 0.25 | 44.5 | 72 | 84.8 | 154-3073 |
| | 53 | 46 F6 | DIN5482 A40x36 | 40 F6 | 50 | 2 | 7.5 | 7 | 21 | 47.5 | 5 | 14 | 0.5 | 44.5 | 70 | 84 | 154-2709 |
| | 53 | 46 F6 | DIN5482 A40x36 | 40 F6 | 50 | 2 | 7.5 | 7 | 21 | 47.5 | 6 | 24 | 0 | 44.5 | 144 | 154 | 154-2285 |
| | 53 | 46 F6 | DIN5482 A40x36 | 40 F6 | 50 | 2 | 7.5 | 7 | 21 | 47.5 | 8 | 16 | 0.25 | 44.5 | 128 | 145 | 154-2707 |

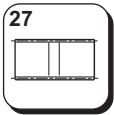

Kg 0.9

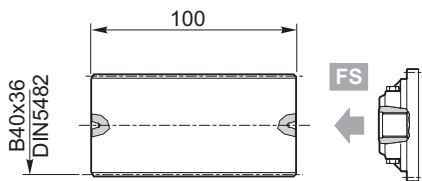

154-3050

Materiale / Materiale / Material
 Matériau / Material / Material:
 Acciaio / Steel / Stahl / Acier / Acero / Aço
39NiCrMo3 UNI 7845 (1.6511)

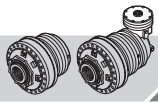

| | | | |
|----|-----|----|----|
| RR | 110 | .. | MS |
| RA | | | MC |

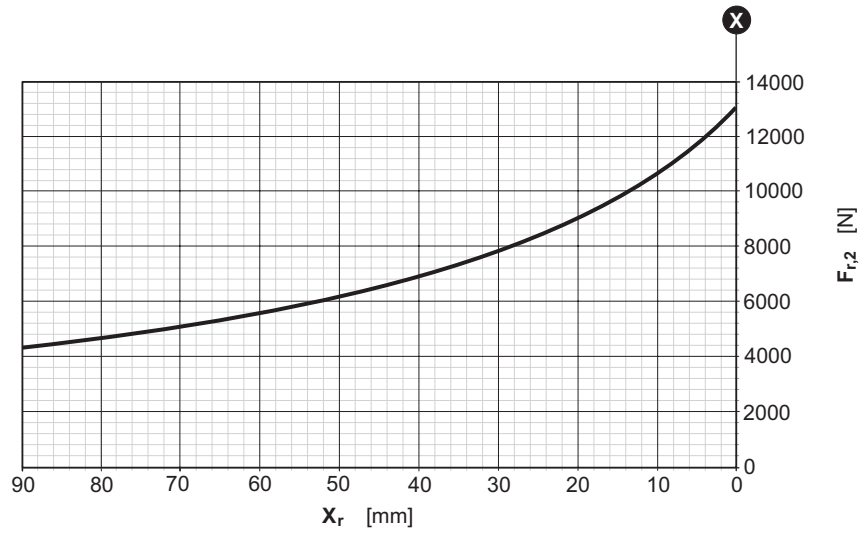
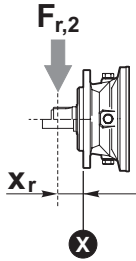

| | | | |
|----|-----|----|----|
| RR | 110 | .. | UC |
| RA | | | |

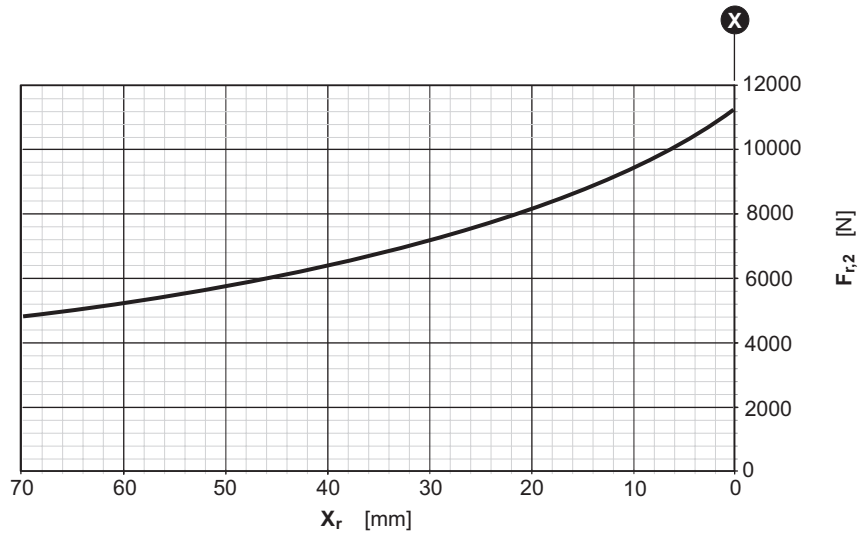
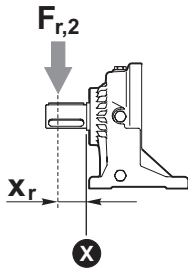

Fattore correttivo k_{r2} / k_{r2} Corrective coefficient / Korrekturfaktor k_{r2}
 Facteur correctif k_{r2} / Factor de corrección k_{r2} / Fator corretivo k_{r2}

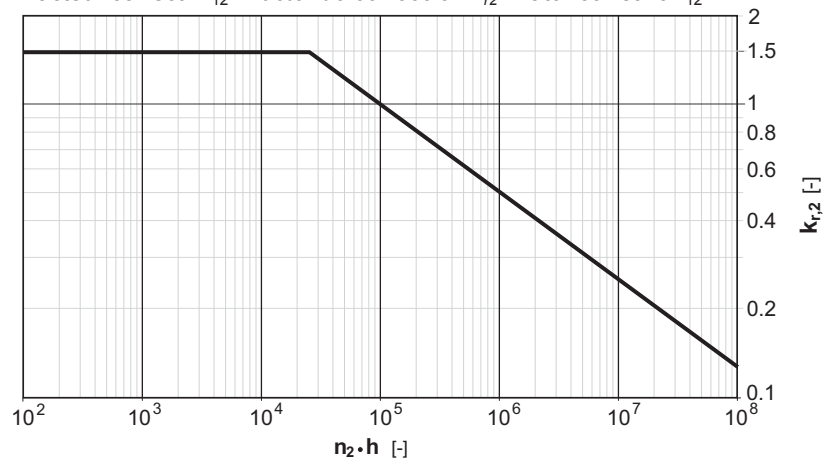

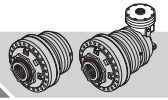



RR210

..

i



| i | T ₂ [Nm] | | | | | | n _{1max} [min ⁻¹] | T _{2max} [Nm] | P _t [kW] | | | | | |
|---------------|-----------------------------|-----------------------------------|---------------------------------|------------------------------|----------------------------------|-------------------------------|---|---------------------------|------------------------|-------------------|------|------|-------------------|---|
| | n ₂ x h | | | | | | | | | | | | | |
| 1/... | 10000 (10 ⁴) | 25000 (2.5 · 10 ⁴) | 50000 (5 · 10 ⁴) | 100000 (10 ⁵) | 500000 (5 · 10 ⁵) | 1000000 (10 ⁶) | | | | | | | | |
| RR210 | 3.31 | 2500 | 2360 | 2330 | 2180 | 1610 | 1310 | 3500 | 2500 (M.../FS) | 15 | | | | |
| | 3.91 | 2480 | 2300 | 2110 | 1860 | 1580 | 1290 | | | | | | | |
| | 4.94 | 2210 | 1860 | 1630 | 1490 | 1350 | 1250 | | | | | | | |
| | 5.78 | 2030 | 1710 | 1500 | 1410 | 1270 | 1220 | | | | | | | |
| | 7.09 | 1390 | 1160 | 1030 | 990 | 890 | 860 | | | | | | | |
| RR210D | 10.96 | 2500 | 2360 | 2330 | 2180 | 1610 | 1310 | 3500 | 2500 (M.../FS) | 8 | | | | |
| | 12.94 | 2500 | 2360 | 2330 | 2180 | 1610 | 1310 | | | | | | | |
| | 15.29 | 2480 | 2300 | 2110 | 1860 | 1580 | 1290 | | | | | | | |
| | 19.32 | 2480 | 2300 | 2110 | 1860 | 1580 | 1290 | | | | | | | |
| | 22.6 | 2480 | 2300 | 2110 | 1860 | 1580 | 1290 | | | | | | | |
| | 28.55 | 2210 | 1860 | 1630 | 1490 | 1350 | 1250 | | | | | | | |
| | 35.02 | 2210 | 1860 | 1630 | 1490 | 1350 | 1250 | | | | | | | |
| | 40.98 | 2030 | 1710 | 1500 | 1410 | 1270 | 1220 | | | | | | | |
| | 50.27 | 1390 | 1160 | 1030 | 990 | 890 | 860 | | | | | | | |
| | RR210T | 60.18 | 2500 | 2360 | 2330 | 2180 | 1610 | | | | 1310 | 3500 | 2500 (M.../FS) | 6 |
| 71.09 | | 2480 | 2300 | 2110 | 1860 | 1580 | 1290 | | | | | | | |
| 80.37 | | 2500 | 2360 | 2330 | 2180 | 1610 | 1310 | | | | | | | |
| 89.82 | | 2480 | 2300 | 2110 | 1860 | 1580 | 1290 | | | | | | | |
| 105.09 | | 2480 | 2300 | 2110 | 1860 | 1580 | 1290 | | | | | | | |
| 119.95 | | 2480 | 2300 | 2110 | 1860 | 1580 | 1290 | | | | | | | |
| 140.34 | | 2480 | 2300 | 2110 | 1860 | 1580 | 1290 | | | | | | | |
| 177.32 | | 2210 | 1860 | 1630 | 1490 | 1350 | 1250 | | | | | | | |
| 217.5 | | 2210 | 1860 | 1630 | 1490 | 1350 | 1250 | | | | | | | |
| 254.49 | | 2030 | 1710 | 1500 | 1410 | 1270 | 1220 | | | | | | | |
| 312.16 | | 1390 | 1160 | 1030 | 990 | 890 | 860 | | | | | | | |
| RR210Q | | 279.84 | 2500 | 2360 | 2330 | 2180 | 1610 | 1310 | 3500 | 2500 (M.../FS) | 5 | | | |
| | | 330.57 | 2480 | 2300 | 2110 | 1860 | 1580 | 1290 | | | | | | |
| | 417.65 | 2480 | 2300 | 2110 | 1860 | 1580 | 1290 | | | | | | | |
| | 488.66 | 2480 | 2300 | 2110 | 1860 | 1580 | 1290 | | | | | | | |
| | 557.76 | 2480 | 2300 | 2110 | 1860 | 1580 | 1290 | | | | | | | |
| | 652.6 | 2480 | 2300 | 2110 | 1860 | 1580 | 1290 | | | | | | | |
| | 824.52 | 2210 | 1860 | 1630 | 1490 | 1350 | 1250 | | | | | | | |
| | 871.54 | 2480 | 2300 | 2110 | 1860 | 1580 | 1290 | | | | | | | |
| | 1011.39 | 2210 | 1860 | 1630 | 1490 | 1350 | 1250 | | | | | | | |
| | 1183.36 | 2030 | 1710 | 1500 | 1410 | 1270 | 1220 | | | | | | | |
| | 1350.69 | 2210 | 1860 | 1630 | 1490 | 1350 | 1250 | | | | | | | |
| | 1580.36 | 2030 | 1710 | 1500 | 1410 | 1270 | 1220 | | | | | | | |
| | 1938.54 | 1390 | 1160 | 1030 | 990 | 890 | 860 | | | | | | | |

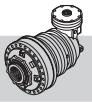

RA210 .. **i**



| | i | T ₂ [Nm] | | | | | | n _{1max} [min ⁻¹] | T _{2max} [Nm] | P _t [kW] |
|---------------|---------------|-----------------------------|-----------------------------------|---------------------------------|------------------------------|----------------------------------|-------------------------------|---|---|------------------------|
| | | n ₂ x h | | | | | | | | |
| | | 10000 (10 ⁴) | 25000 (2.5 · 10 ⁴) | 50000 (5 · 10 ⁴) | 100000 (10 ⁵) | 500000 (5 · 10 ⁵) | 1000000 (10 ⁶) | | | |
| RA210 | 1/... | | | | | | | | | |
| | 10.66 | 1980 | 1660 | 1460 | 1310 | 1170 | 1010 | 3500 | 2500 (M.../FS) 3300 (S...) | 14 |
| | 12.59 | 2270 | 1900 | 1670 | 1530 | 1360 | 1130 | | | |
| | 15.91 | 2210 | 1860 | 1630 | 1490 | 1350 | 1250 | | | |
| | 18.61 | 2030 | 1710 | 1500 | 1410 | 1270 | 1220 | | | |
| | 22.83 | 1390 | 1160 | 1030 | 990 | 890 | 860 | | | |
| | 29.09 | 1000 | 830 | 770 | 730 | 640 | 600 | | | |
| | 34.03 | 1140 | 940 | 890 | 840 | 740 | 700 | | | |
| | 41.75 | 1340 | 1130 | 1030 | 990 | 890 | 840 | | | |
| RA210D | | | | | | | | | | |
| | 35.28 | 2500 | 2360 | 2330 | 2180 | 1610 | 1310 | 3500 | 2500 (M.../FS) 3300 (S...) | 10 |
| | 41.67 | 2500 | 2360 | 2330 | 2180 | 1610 | 1310 | | | |
| | 49.23 | 2480 | 2300 | 2110 | 1860 | 1580 | 1290 | | | |
| | 62.20 | 2480 | 2300 | 2110 | 1860 | 1580 | 1290 | | | |
| | 72.77 | 2480 | 2300 | 2110 | 1860 | 1580 | 1290 | | | |
| | 91.94 | 2210 | 1860 | 1630 | 1490 | 1350 | 1250 | | | |
| | 112.78 | 2210 | 1860 | 1630 | 1490 | 1350 | 1250 | | | |
| | 131.96 | 2030 | 1710 | 1500 | 1410 | 1270 | 1220 | | | |
| | 161.86 | 1390 | 1160 | 1030 | 990 | 890 | 860 | | | |
| | 196.71 | 2030 | 1710 | 1500 | 1410 | 1270 | 1220 | | | |
| | 206.22 | 2210 | 1860 | 1630 | 1490 | 1350 | 1250 | | | |
| | 241.29 | 2030 | 1710 | 1500 | 1410 | 1270 | 1220 | | | |
| | 295.98 | 1390 | 1160 | 1030 | 990 | 890 | 860 | | | |



RR210 .. i ..

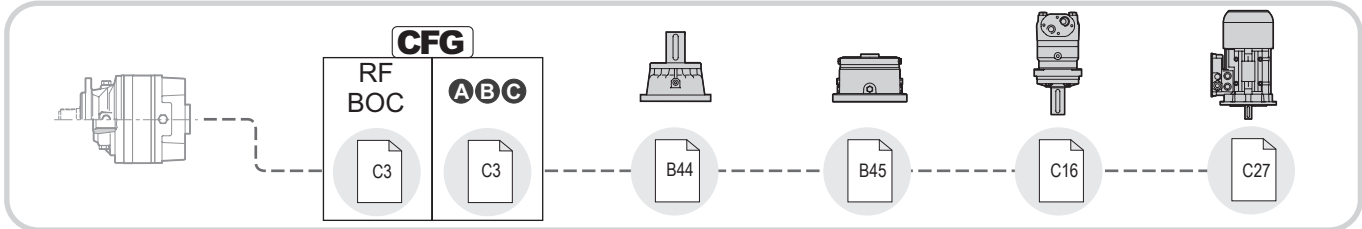
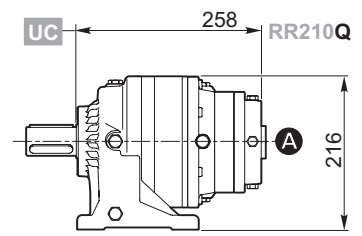
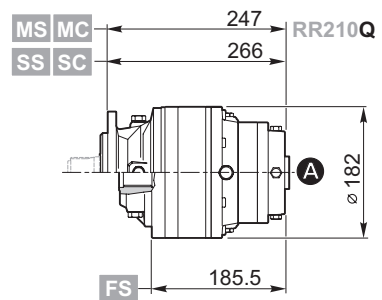
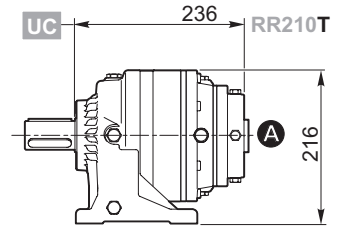
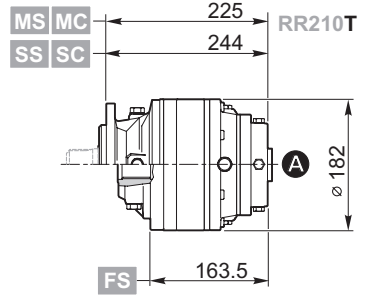
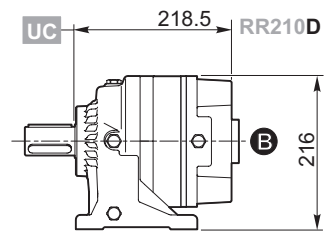
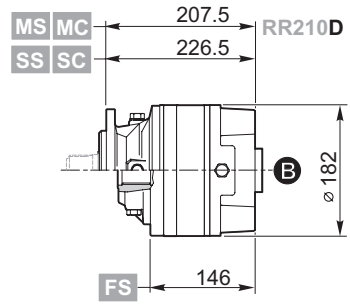
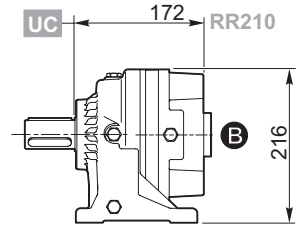
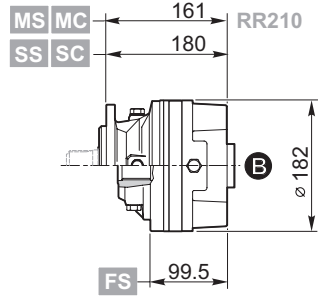

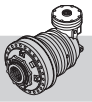

RA210 .. i ..



D

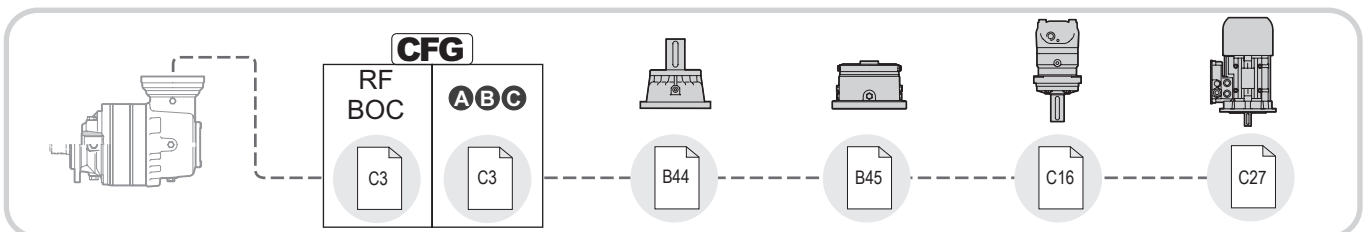
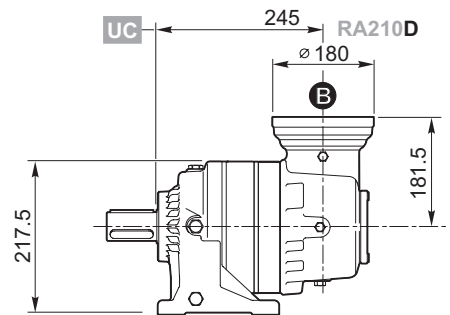
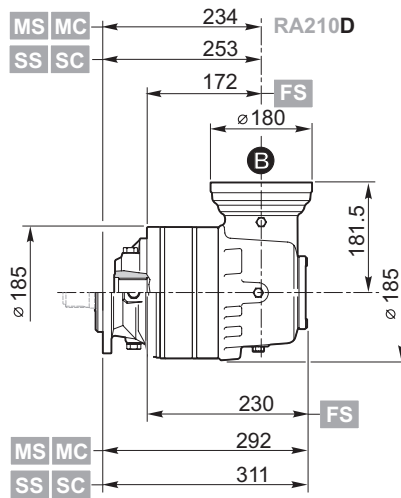
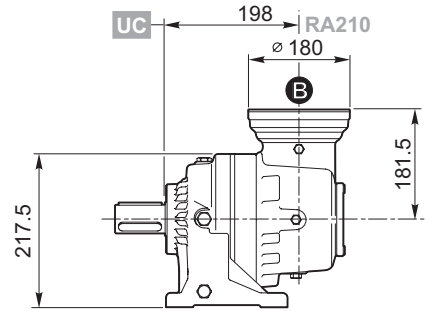
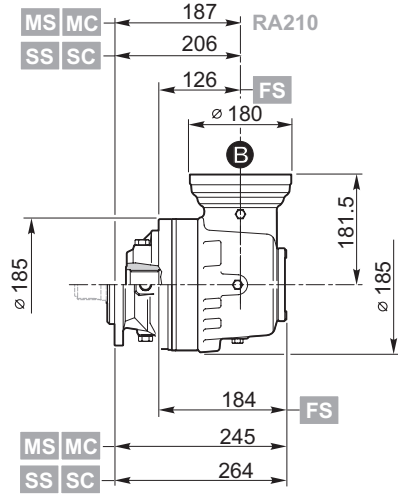

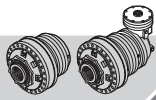

210

IT EN DEFRES PT

| | | | |
|-------|----|---|----|
| RR210 | .. | i | .. |
| RA210 | .. | | |

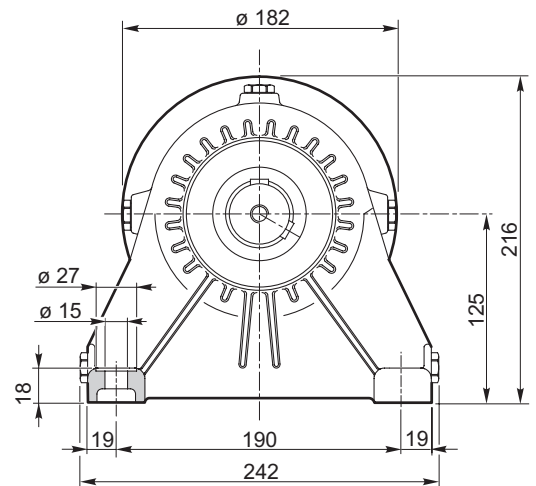
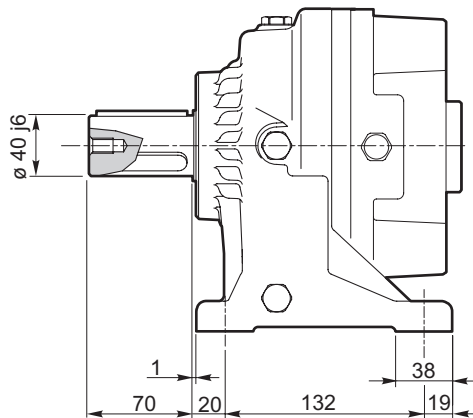
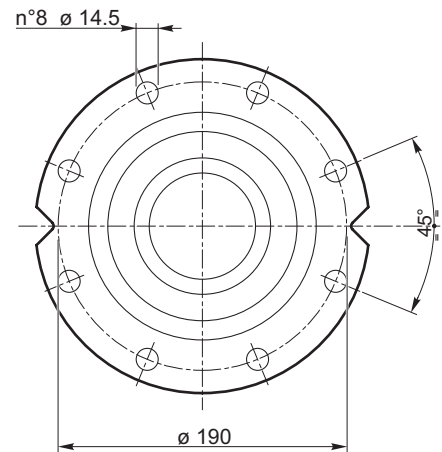
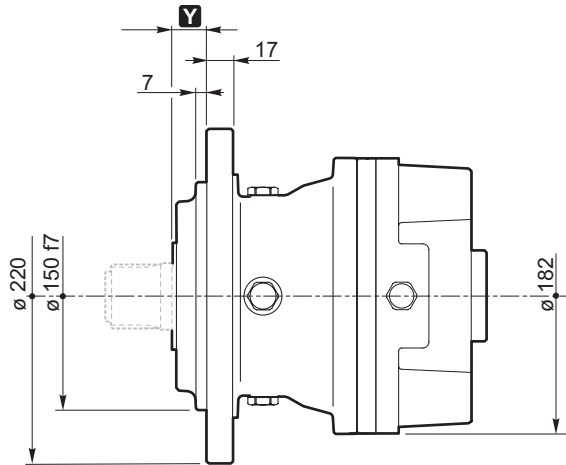
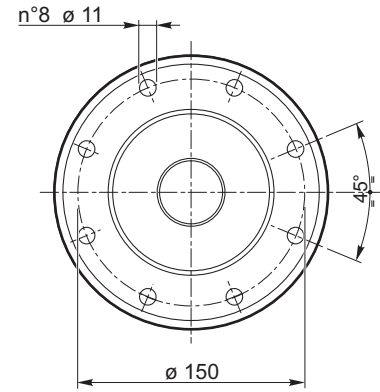
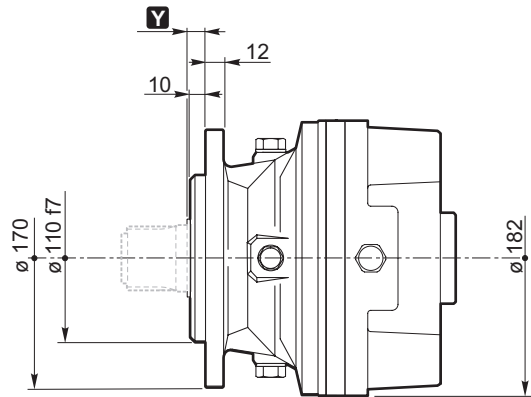

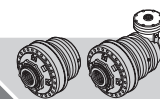

MS

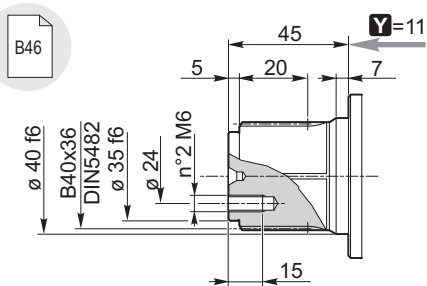
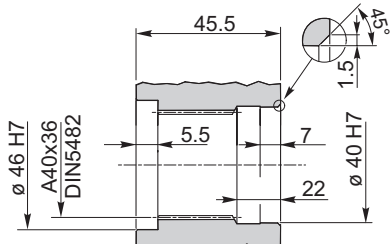
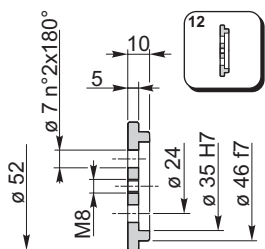

SS

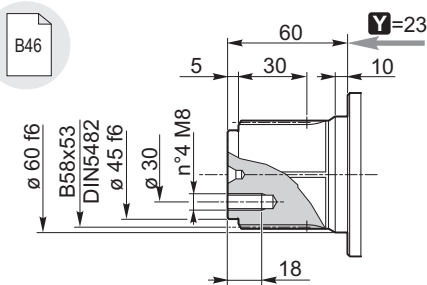
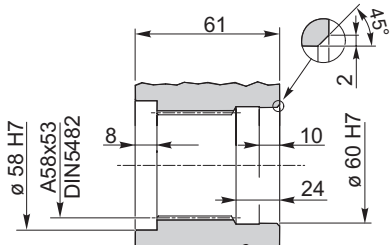
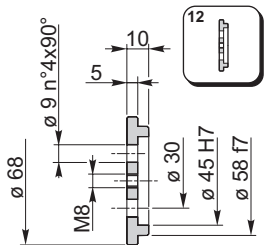

MC
UC

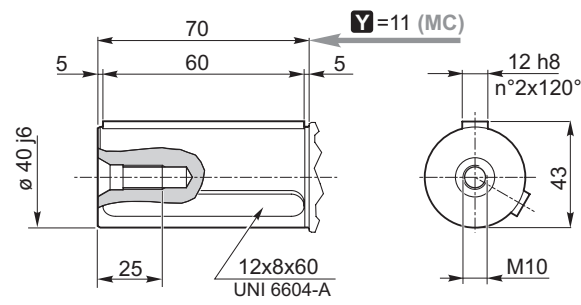
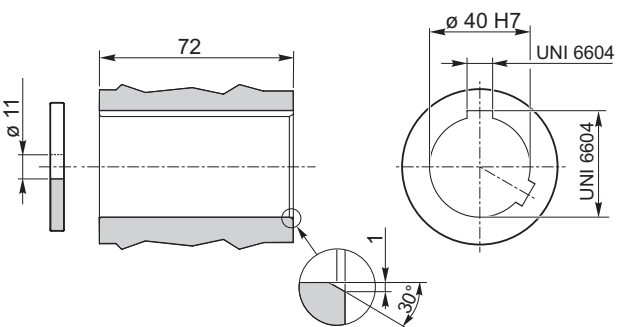

SC

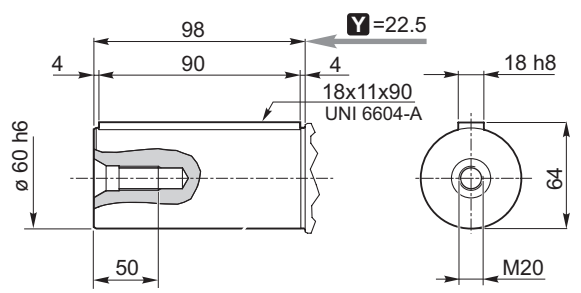
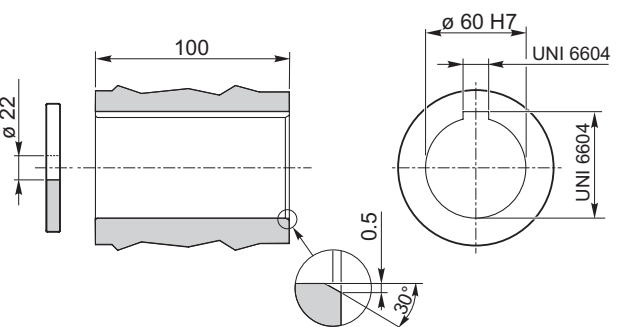

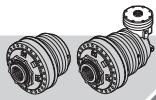

210

IT EN DEFRES PT

| | | | |
|-------|----|---|-----------|
| RR210 | .. | i | FS |
| RA210 | | | |

FS

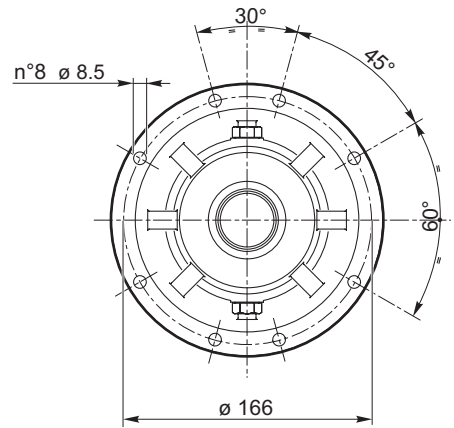
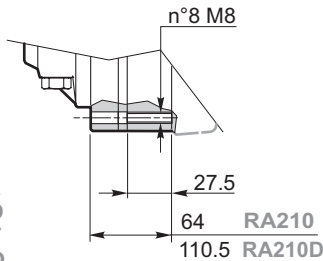
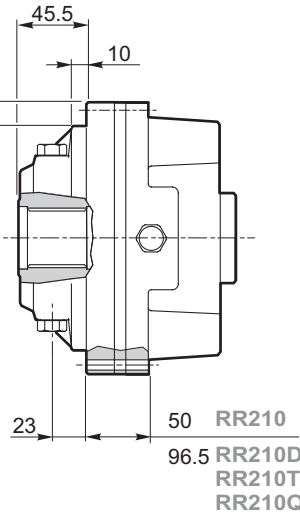

Trattamento termico:
Tempra ad induzione secondo UNI 10932 su scanalato interno

Heat treatment:
Induction hardening according to UNI 10932 on internal spline

Wärmebehandlung:
Induktionshärtung nach UNI 10932 an interner Nut

Traitement thermique :
Trempe par induction conformément à la norme UNI 10932 sur cannelé interne

Tratamiento térmico:
Temple por inducción según UNI 10932 en acanalado interno

Tratamento térmico:
Tempera por indução segundo UNI 10932 sobre ranhuras internas

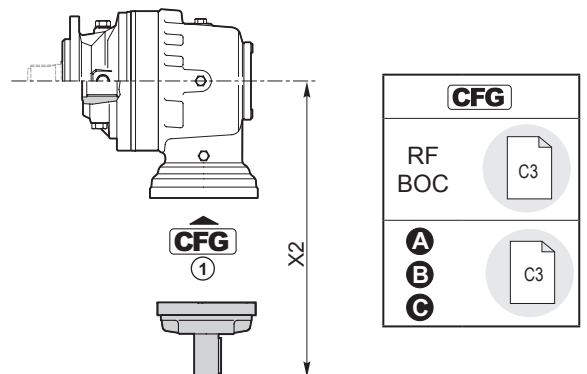
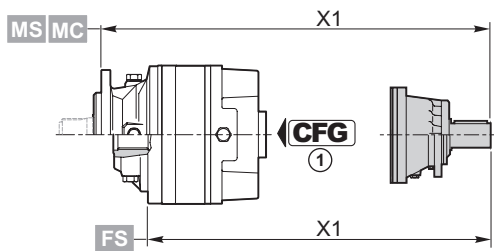
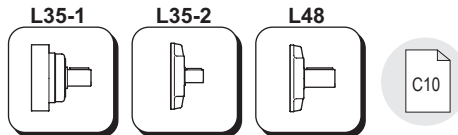
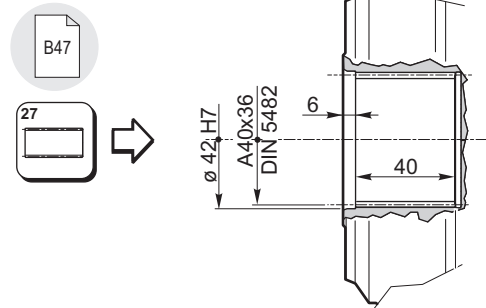
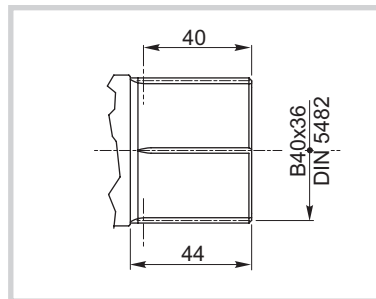

| | CFG ① | | code | X1 |
|---------------|-----------------|--------------|------------|--|
| RR210 | BOC | L48 | 154B3989M1 | 282.5 (M...) 221 (FS) 301.5 (S...) |
| RR210D | BOC | L35-2 | 154-2190M1 | 297 (M...) 235.5 (FS) 316.5 (S...) |
| RR210T | RF | L35-1 | 154B4054 | 313 (M...) 251.5 (FS) 332 (S...) |
| RR210Q | RF | L35-1 | 154B4054M1 | 335 (M...) 273.5 (FS) 354 (S...) |

| | CFG ① | | code | X2 |
|---------------|-----------------|--------------|------------|-------|
| RA210 | BOC | L35-2 | 154-2190M1 | 270.5 |
| RA210D | BOC | L35-2 | 154-2190M1 | 270.5 |

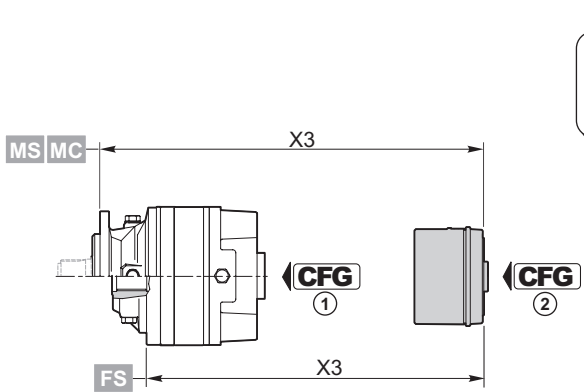
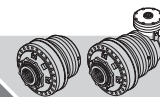

| CFG | |
|--------|----|
| RF BOC | C3 |
| A | C3 |
| B | |
| C | |

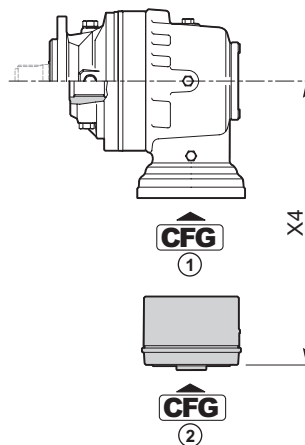

| RF2/.. | CFG ① | T _f [Nm] | CFG ② | | | | | | | |
|--------|-------|---------------------|------------|--|-----------------------|------------------------|-----------------------|------------------------|--|--|
| | | | B | | OMP/OMR SAE A 2B Ø 25 | OMP/OMR SAE A 2B 1" 6B | OMP/OMR SAE A 4B Ø 25 | OMP/OMR SAE A 4B 1" 6B | X3 | |
| | | | code | X3 | code | code | code | code | | |
| RR210 | RF | 70 | 154-2838M1 | 199.5 (M...) 138 (FS) 218.5 (S...) | 154-2863 | 154-2863M11 | 154-2635 | 154-2635M11 | 189.5 (M...) 128 (FS) 208.5 (S...) | |
| | | 140 | 154-2839M1 | | 154-2864 | 154-2864M11 | 154-2636 | 154-2636M11 | | |
| | | 210 | 154-2840M1 | | 154-2865 | 154-2865M11 | 154-2637 | 154-2637M11 | | |
| | | 320 | 154-2841M1 | | 154-2866 | 154-2866M11 | 154-2638 | 154-2638M11 | | |
| | | 430 | 154-2842M1 | | 154-2867 | 154-2867M11 | 154-2639 | 154-2639M11 | | |
| | | 600 | 154B8962M1 | | 154B9665 | 154B9665M11 | 154B9666 | 154B9666M11 | | |
| RR210D | RF | 70 | 154-2838M1 | 246 (M...) 184.5 (FS) 265 (S...) | 154-2863 | 154-2863M11 | 154-2635 | 154-2635M11 | 236 (M...) 174.5 (FS) 255 (S...) | |
| | | 140 | 154-2839M1 | | 154-2864 | 154-2864M11 | 154-2636 | 154-2636M11 | | |
| | | 210 | 154-2840M1 | | 154-2865 | 154-2865M11 | 154-2637 | 154-2637M11 | | |
| | | 320 | 154-2841M1 | | 154-2866 | 154-2866M11 | 154-2638 | 154-2638M11 | | |
| | | 430 | 154-2842M1 | | 154-2867 | 154-2867M11 | 154-2639 | 154-2639M11 | | |
| | | 600 | 154B8962M1 | | 154B9665 | 154B9665M11 | 154B9666 | 154B9666M11 | | |

| | CFG ① | T _f [Nm] | CFG ② | | | | | | | |
|--------|-------|---------------------|------------|--|-----------------------|------------------------|-----------------------|------------------------|--|--|
| | | | A | | OMP/OMR SAE A 2B Ø 25 | OMP/OMR SAE A 2B 1" 6B | OMP/OMR SAE A 4B Ø 25 | OMP/OMR SAE A 4B 1" 6B | X3 | |
| | | | code | X3 | code | code | code | code | | |
| RR210T | RF | 70 | 154-2832M1 | 291 (M...) 229.5 (FS) 310 (S...) | 154-2858M1 | 154-2858M5 | | | 286.5 (M...) 225 (FS) 305.5 (S...) | |
| | | 140 | 154-2833M1 | | 154-2859M1 | 154-2859M5 | | | | |
| | | 210 | 154-2834M1 | | 154-2860M1 | 154-2860M5 | | | | |
| | | 320 | 154-2836M1 | | 154-2861M1 | 154-2861M5 | | | | |
| | | 430 | 154-2837M1 | | 154-2862M1 | 154-2862M5 | | | | |
| | | 600 | 154B8959M1 | | 154B9663M1 | 154B9663M5 | | | | |
| RR210Q | RF | 70 | 154-2832M3 | 313 (M...) 251.5 (FS) 332 (S...) | 154-2858M3 | 154-2858M7 | | | 308.5 (M...) 247.5 (FS) 327.5 (S...) | |
| | | 140 | 154-2833M3 | | 154-2859M3 | 154-2859M7 | | | | |
| | | 210 | 154-2834M3 | | 154-2860M3 | 154-2860M7 | | | | |
| | | 320 | 154-2836M3 | | 154-2861M3 | 154-2861M7 | | | | |
| | | 430 | 154-2837M3 | | 154-2862M3 | 154-2862M7 | | | | |
| | | 600 | 154B8959M3 | | 154B9663M3 | 154B9663M7 | | | | |

| | CFG ① | T _f [Nm] | CFG ② | | | | | | | |
|--------|-------|---------------------|-------------|-------|-----------------------|------------------------|-----------------------|------------------------|-------|--|
| | | | B | | OMP/OMR SAE A 2B Ø 25 | OMP/OMR SAE A 2B 1" 6B | OMP/OMR SAE A 4B Ø 25 | OMP/OMR SAE A 4B 1" 6B | X4 | |
| | | | code | X4 | code | code | code | code | | |
| RA210 | RF | 70 | 154-2838M12 | 223.8 | 154-2863M12 | 154-2863M13 | 154-2635M12 | | 213.8 | |
| | | 140 | 154-2839M12 | | 154-2864M12 | 154-2864M13 | 154-2636M12 | | | |
| | | 210 | 154-2840M12 | | 154-2865M12 | 154-2865M13 | 154-2637M12 | | | |
| | | 320 | 154-2841M12 | | 154-2866M12 | 154-2866M13 | 154-2638M12 | | | |
| | | 430 | 154-2842M12 | | 154-2867M12 | 154-2867M13 | 154-2639M12 | | | |
| | | 600 | 154B8962M12 | | 154B9665M12 | 154B9665M13 | 154B9666M12 | | | |
| RA210D | RF | 70 | 154-2838M12 | 223.8 | 154-2863M12 | 154-2863M13 | 154-2635M12 | | 213.8 | |
| | | 140 | 154-2839M12 | | 154-2864M12 | 154-2864M13 | 154-2636M12 | | | |
| | | 210 | 154-2840M12 | | 154-2865M12 | 154-2865M13 | 154-2637M12 | | | |
| | | 320 | 154-2841M12 | | 154-2866M12 | 154-2866M13 | 154-2638M12 | | | |
| | | 430 | 154-2842M12 | | 154-2867M12 | 154-2867M13 | 154-2639M12 | | | |
| | | 600 | 154B8962M12 | | 154B9665M12 | 154B9665M13 | 154B9666M12 | | | |

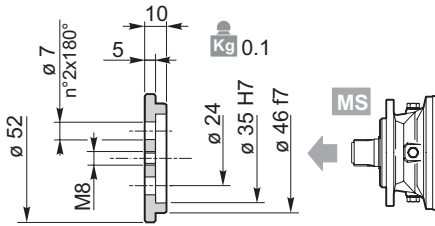
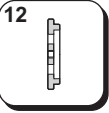
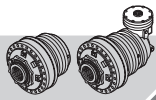

154-3063

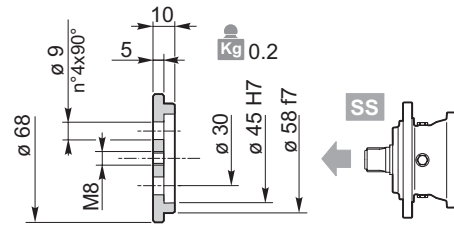

154-3061

Materiale / Material / Material / Matériau / Material / Material:
Acciaio / Steel / Stahl / Acier / Acero / Aço
C40 EN 10083-1 (1.1186)

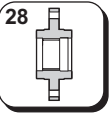

Materiale / Material / Material / Matériau / Material / Material:
Acciaio / Steel / Stahl / Acier / Acero / Aço EN 10083-1-C40 (1.1186)

Trattamento termico:
 Tempra ad induzione secondo UNI 10932 su scanalato interno
Heat treatment:
 Induction hardening according to UNI 10932 on internal spline
Wärmebehandlung:
 Induktionshärtung nach UNI 10932 an interner Nut
Traitement thermique :
 Trempe par induction conformément à la norme UNI 10932 sur cannelé interne
Tratamiento térmico:
 Temple por inducción según UNI 10932 en acanalado interno
Tratamento térmico:
 Tempera por indução segundo UNI 10932 sobre ranhuras internas

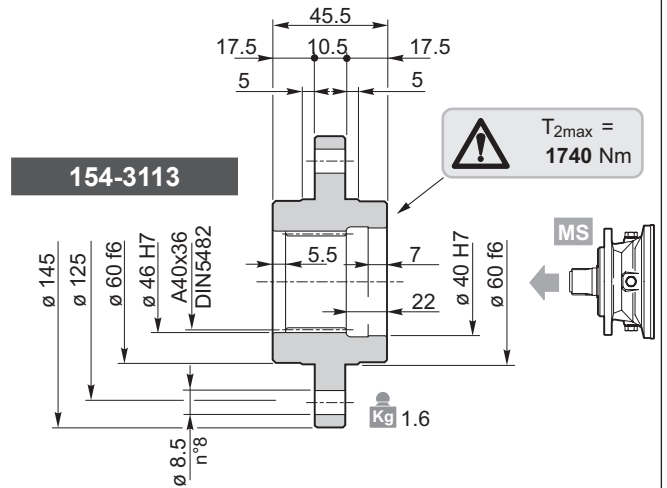

154-3113

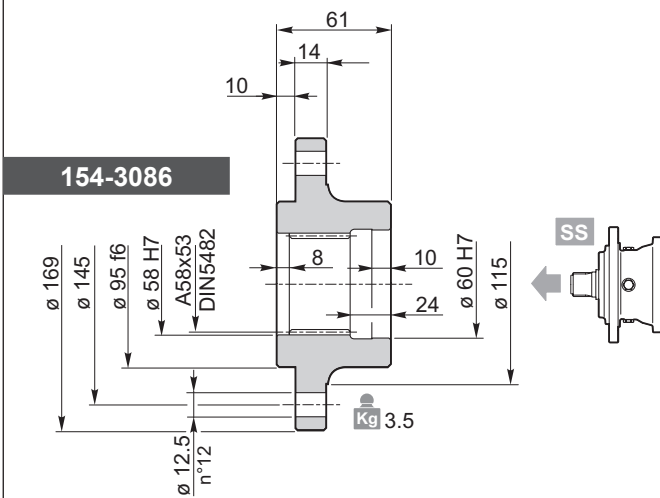

154-3086

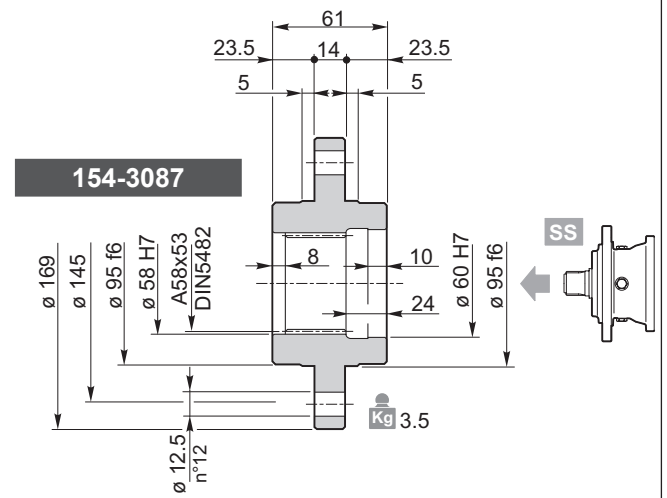

154-3087



Materiale / Material / Material / Matériau / Material / Material: **Acciaio / Steel / Stahl / Acier / Acero / Aço 39NiCrMo3 UNI 7845 (1.6511)**

Trattamento termico:
 Tempra ad induzione secondo UNI 10932 su scanalato interno
Heat treatment:
 Induction hardening according to UNI 10932 on internal spline
Wärmebehandlung:
 Induktionshärtung nach UNI 10932 an interner Nut

Traitement thermique :
 Trempe par induction conformément à la norme UNI 10932 sur cannelé interne
Tratamiento térmico:
 Temple por inducción según UNI 10932 en acanalado interno
Tratamento térmico:
 Tempera por indução segundo UNI 10932 sobre ranhuras internas

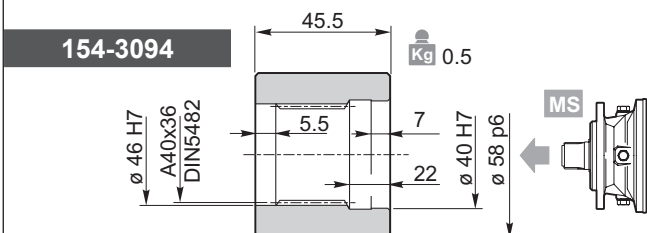

154-3094

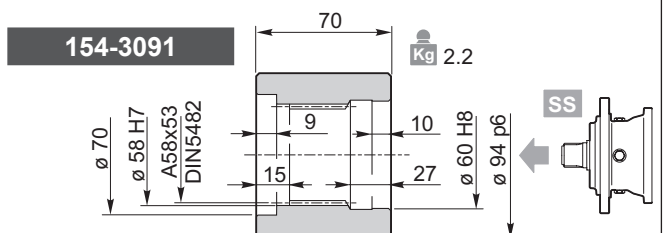

154-3091

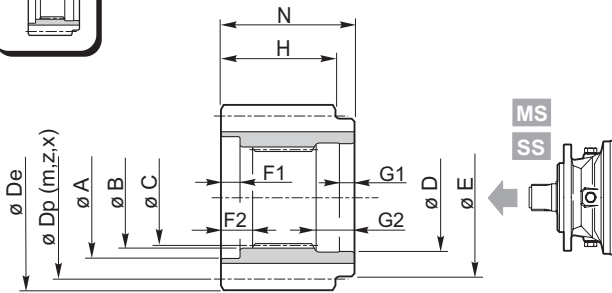
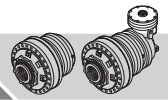

Materiale / Material / Material
 Matériau / Material / Material
 Acciaio / Steel / Stahl / Acier / Acero / Aço
39NiCrMo3 UNI 7845 (1.6511)

Trattamento termico:
 Tempra ad induzione secondo UNI 10932 su scanalato interno

Heat treatment:
 Induction hardening according to UNI 10932 on internal spline

Wärmebehandlung:
 Induktionshärtung nach UNI 10932 an interner Nut

Traitement thermique:
 Trempe par induction conformément à la norme UNI 10932 sur cannelé interne

Tratamiento térmico:
 Temple por inducción según UNI 10932 en acanalado interno

Tratamento térmico:
 Tempera por indução segundo UNI 10932 sobre ranhuras internas

| | A | B | C | D | E | F1 | F2 | G1 | G2 | N | m | z | x | H | Dp | De | Code |
|----|----|-------|-------------------|-------|----|----|-----|----|----|------|-----|----|--------|------|-----|-------|----------|
| MS | 53 | 46 F6 | DIN5482 A40x36 | 40 F6 | 50 | 2 | 7.5 | 7 | 21 | 47.5 | 4 | 15 | 0.5 | 44.5 | 60 | 69.8 | 154-3072 |
| | 53 | 46 F6 | DIN5482 A40x36 | 40 F6 | 50 | 2 | 7.5 | 7 | 21 | 47.5 | 4 | 32 | 0 | 44.5 | 128 | 135 | 154-3104 |
| | 53 | 46 F6 | DIN5482 A40x36 | 40 F6 | 50 | 2 | 7.5 | 7 | 21 | 47.5 | 6 | 12 | 0.25 | 44.5 | 72 | 84.8 | 154-3073 |
| | 53 | 46 F6 | DIN5482 A40x36 | 40 F6 | 50 | 2 | 7.5 | 7 | 21 | 47.5 | 5 | 14 | 0.5 | 44.5 | 70 | 84 | 154-2709 |
| | 53 | 46 F6 | DIN5482 A40x36 | 40 F6 | 50 | 2 | 7.5 | 7 | 21 | 47.5 | 6 | 24 | 0 | 44.5 | 144 | 154 | 154-2285 |
| | 53 | 46 F6 | DIN5482 A40x36 | 40 F6 | 50 | 2 | 7.5 | 7 | 21 | 47.5 | 8 | 16 | 0.25 | 44.5 | 128 | 145 | 154-2707 |
| SS | 70 | 58 H7 | DIN5482 A58x53 | 60 H7 | 72 | 7 | 13 | 12 | 27 | 68 | 4.5 | 18 | 0.4444 | 65 | 81 | 93 | 154-3106 |
| | 70 | 58 H7 | DIN5482 A58x53 | 60 H7 | 68 | 7 | 13 | 10 | 27 | 68 | 5 | 17 | 0.4 | 65 | 85 | 98 | 154-2287 |
| | 70 | 58 H7 | DIN5482 A58x53 | 60 H7 | 68 | 7 | 13 | 10 | 27 | 68 | 5 | 19 | 0 | 65 | 95 | 104 | 154-2286 |
| | 70 | 58 H7 | DIN5482 A58x53 | 60 H7 | 75 | 7 | 13 | 12 | 27 | 68 | 6 | 14 | 0.5 | 65 | 84 | 101.5 | 154-3082 |
| | 70 | 58 H7 | DIN5482 A58x53 | 60 H7 | 68 | 7 | 13 | 10 | 27 | 68 | 6 | 15 | 0.25 | 65 | 90 | 103 | 154-3107 |
| | 70 | 58 H7 | DIN5482 A58x53 | 60 H7 | 68 | 7 | 13 | 10 | 27 | 68 | 6 | 16 | 0.25 | 65 | 96 | 109 | 154-3245 |
| | 70 | 58 H7 | DIN5482 A58x53 | 60 H7 | 78 | 7 | 13 | 12 | 27 | 68 | 8 | 12 | 0.5 | 65 | 96 | 118 | 154-3074 |
| | 70 | 58 H7 | DIN5482 A58x53 | 60 H7 | 68 | 7 | 13 | 10 | 27 | 68 | 8 | 14 | 0 | 65 | 112 | 126 | 154-3250 |
| | 70 | 58 H7 | DIN5482 A58x53 | 60 H7 | 78 | 7 | 13 | 12 | 27 | 68 | 8 | 15 | 0 | 65 | 120 | 136 | 154-3246 |
| | 70 | 58 H7 | DIN5482 A58x53 | 60 H7 | 68 | 7 | 13 | 10 | 27 | 68 | 8 | 15 | 0.25 | 65 | 120 | 138 | 154-3235 |
| | 70 | 58 H7 | DIN5482 A58x53 | 60 H7 | 78 | 7 | 13 | 12 | 27 | 68 | 8 | 18 | 0 | 65 | 144 | 158 | 154-3103 |
| | 70 | 58 H7 | DIN5482 A58x53 | 60 H7 | 78 | 7 | 13 | 12 | 27 | 68 | 10 | 10 | 0.25 | 65 | 100 | 124.5 | 154-3075 |
| | 70 | 58 H7 | DIN5482 A58x53 | 60 H7 | 78 | 7 | 13 | 12 | 27 | 68 | 10 | 12 | 0.475 | 65 | 120 | 149.5 | 154-3105 |
| | 70 | 58 H7 | DIN5482 A58x53 | 60 H7 | 68 | 7 | 13 | 10 | 27 | 68 | 10 | 15 | 0 | 65 | 150 | 167 | 154-3248 |

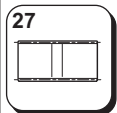

Kg 0.9

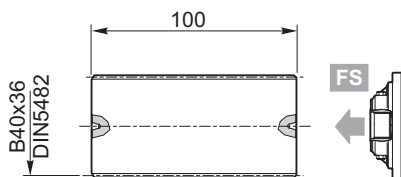

154-3050

Materiale / Materiale / Material
 Matériau / Material / Material
 Acciaio / Steel / Stahl / Acier / Acero / Aço
39NiCrMo3 UNI 7845 (1.6511)

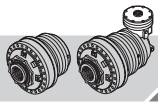

210

IT EN DE FR ES PT

| | | | |
|----|-----|----|-----------|
| RR | 210 | .. | MS |
| RA | | | MC |

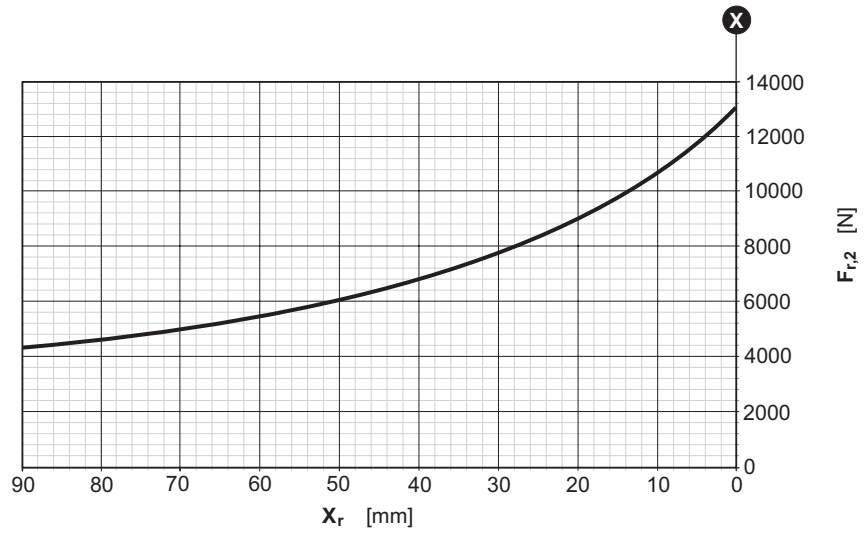
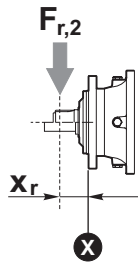

| | | | |
|----|-----|----|-----------|
| RR | 210 | .. | SS |
| RA | | | SC |

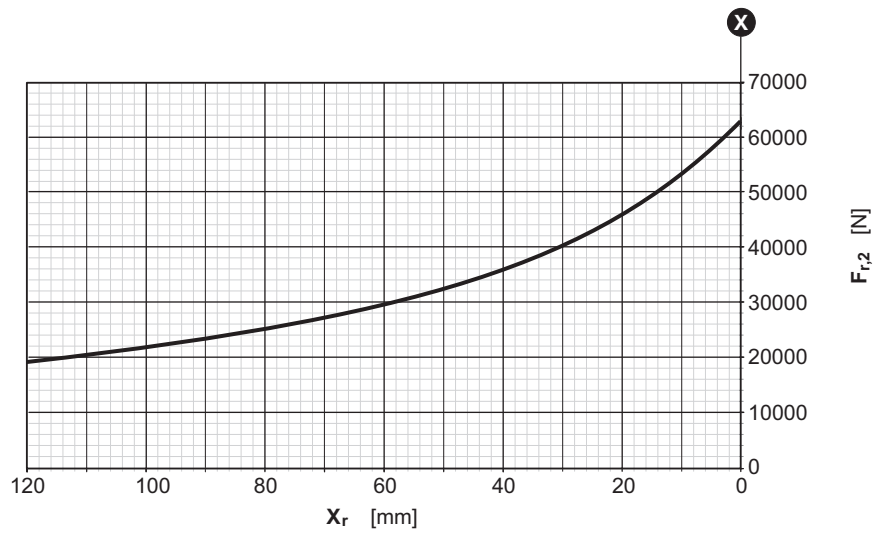
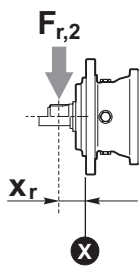

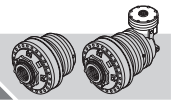

| | | | |
|----|-----|----|----|
| RR | 210 | .. | UC |
| RA | | | |

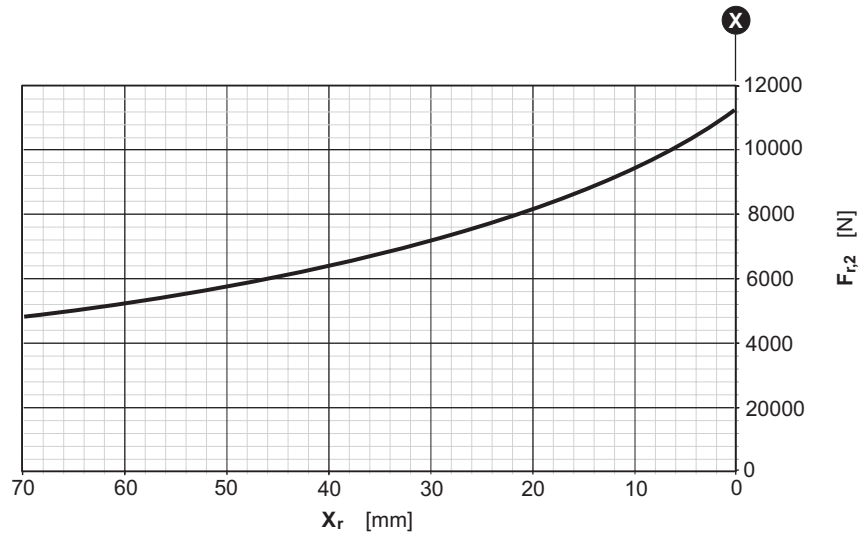
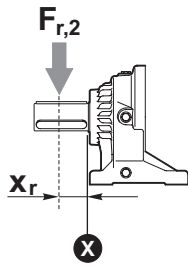

Fattore correttivo k_{r2} / k_{r2} Corrective coefficient / Korrekturfaktor k_{r2}
 Facteur correctif k_{r2} / Factor de corrección k_{r2} / Fator corretivo k_{r2}

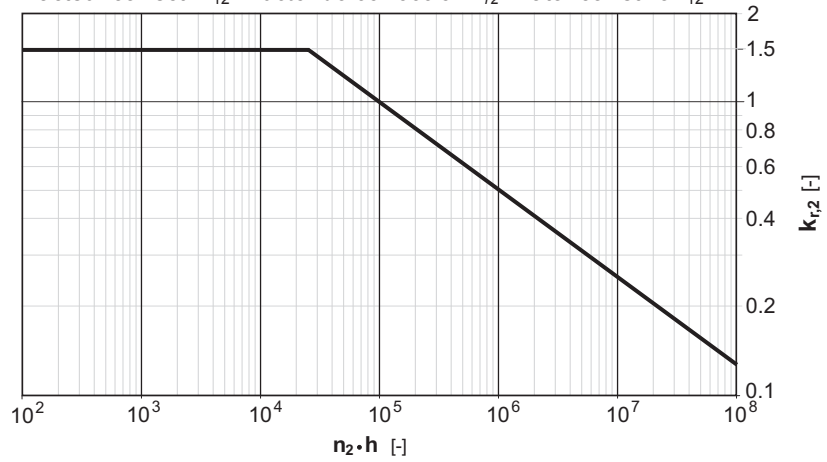



310

IT EN DE FR ES PT

RR310 .. **i**



| | i 1/... | T ₂ [Nm] | | | | | | n _{1max} [min ⁻¹] | T _{2max} [Nm] | P _t [kW] |
|---------------|----------------|-----------------------------|-----------------------------------|---------------------------------|------------------------------|----------------------------------|-------------------------------|---|---------------------------|------------------------|
| | | n ₂ x h | | | | | | | | |
| | | 10000 (10 ⁴) | 25000 (2.5 · 10 ⁴) | 50000 (5 · 10 ⁴) | 100000 (10 ⁵) | 500000 (5 · 10 ⁵) | 1000000 (10 ⁶) | | | |
| RR310 | 3.40 | 3640 | 3440 | 3350 | 3070 | 2520 | 2040 | 3500 | 5500 (M.../FS) | 20 |
| | 4.00 | 3580 | 3310 | 2980 | 2650 | 2400 | 2010 | | | |
| | 5.00 | 2970 | 2500 | 2190 | 2020 | 1830 | 1750 | | | |
| | 5.80 | 2610 | 2200 | 1930 | 1820 | 1650 | 1580 | | | |
| | 7.00 | 2020 | 1690 | 1500 | 1440 | 1300 | 1250 | | | |
| RR310D | 12.84 | 3580 | 3310 | 2980 | 2650 | 2400 | 1950 | 3500 | 5500 (M.../FS) | 12 |
| | 16.40 | 3580 | 3310 | 2980 | 2650 | 2320 | 1880 | | | |
| | 21.68 | 3460 | 3090 | 2960 | 2650 | 2260 | 1840 | | | |
| | 28.80 | 2270 | 2110 | 2030 | 1950 | 1770 | 1700 | | | |
| | 31.44 | 2610 | 2200 | 1930 | 1820 | 1650 | 1580 | | | |
| | 41.76 | 2610 | 2200 | 1930 | 1820 | 1650 | 1580 | | | |
| | 50.40 | 2020 | 1690 | 1500 | 1440 | 1300 | 1250 | | | |
| | RR310T | 57.56 | 3580 | 3310 | 2980 | 2650 | 2320 | | | |
| 76.26 | | 3580 | 3310 | 2980 | 2650 | 2320 | 1880 | | | |
| 100.81 | | 3460 | 3090 | 2960 | 2650 | 2260 | 1840 | | | |
| 134.63 | | 3460 | 3090 | 2960 | 2650 | 2260 | 1840 | | | |
| 146.18 | | 2610 | 2200 | 1930 | 1820 | 1650 | 1580 | | | |
| 178.85 | | 2270 | 2110 | 2030 | 1950 | 1770 | 1700 | | | |
| 195.22 | | 2610 | 2200 | 1930 | 1820 | 1650 | 1580 | | | |
| 223.56 | | 2750 | 2500 | 2190 | 2020 | 1830 | 1750 | | | |
| 259.33 | | 2610 | 2200 | 1930 | 1820 | 1650 | 1580 | | | |
| 312.98 | | 2020 | 1690 | 1500 | 1440 | 1300 | 1250 | | | |
| RR310Q | | 357.47 | 3580 | 3310 | 2980 | 2650 | 2320 | 1880 | 3500 | 5500 (M.../FS) |
| | 473.57 | 3580 | 3310 | 2980 | 2650 | 2320 | 1880 | | | |
| | 513.08 | 2610 | 2200 | 1930 | 1820 | 1650 | 1580 | | | |
| | 626.04 | 3460 | 3090 | 2960 | 2650 | 2260 | 1840 | | | |
| | 836.07 | 3460 | 3090 | 2960 | 2650 | 2260 | 1840 | | | |
| | 907.76 | 2610 | 2200 | 1930 | 1820 | 1650 | 1580 | | | |
| | 1110.65 | 2270 | 2110 | 2030 | 1950 | 1770 | 1700 | | | |
| | 1212.30 | 2610 | 2200 | 1930 | 1820 | 1650 | 1580 | | | |
| | 1388.31 | 2750 | 2500 | 2190 | 2020 | 1830 | 1750 | | | |
| | 1610.44 | 2610 | 2200 | 1930 | 1820 | 1650 | 1580 | | | |
| | 1943.63 | 2020 | 1690 | 1500 | 1440 | 1300 | 1250 | | | |

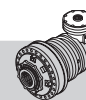

RA310 .. **i**



| | i | T ₂ [Nm] | | | | | | n _{1max} [min ⁻¹] | T _{2max} [Nm] | P _t [kW] |
|---------------|--|--|--|--|--|--|--|---|---|------------------------|
| | | n ₂ x h | | | | | | | | |
| | | 10000 (10 ⁴) | 25000 (2.5 · 10 ⁴) | 50000 (5 · 10 ⁴) | 100000 (10 ⁵) | 500000 (5 · 10 ⁵) | 1000000 (10 ⁶) | | | |
| RA310 | 10.95 12.88 18.68 22.54 29.44 34.15 41.22 | 2020 2310 2610 2020 1010 1140 1320 | 1700 1940 2200 1690 840 940 1120 | 1490 1700 1930 1500 780 890 1060 | 1350 1570 1820 1440 730 840 1000 | 1200 1390 1650 1300 640 740 880 | 1030 1150 1490 1250 610 700 830 | 3500 | 5500 (M.../FS) 6500 (S...) | 18 |
| RA310D | 41.34 52.81 69.81 92.74 101.22 134.47 162.29 169.57 185.10 211.97 223.39 245.88 296.76 | 3580 3580 3460 2270 2610 2610 2020 2270 2610 2750 2020 2610 2020 | 3310 3310 3090 2110 2200 2200 1690 2110 2200 2500 1690 2200 1690 | 2980 2980 2960 2030 1930 1930 1500 2030 1930 2190 1500 1930 1500 | 2650 2650 2650 1950 1820 1820 1440 1950 1820 2020 1440 1820 1440 | 2400 2320 2260 1770 1650 1650 1300 1770 1650 1830 1300 1650 1300 | 1950 1880 1840 1700 1580 1580 1250 1700 1580 1750 1250 1580 1250 | 3500 | 5500 (M.../FS) 6500 (S...) | 13 |
| RA310T | 216.51 286.22 357.77 372.10 431.64 475.27 551.32 628.29 834.62 968.16 1168.47 1220.94 1332.69 1526.17 1608.41 1770.36 2136.64 | 3580 3580 2970 2970 2610 2970 2610 2970 2750 2610 2020 2270 2610 2750 2020 2610 2020 2610 2020 | 3310 3310 2500 2500 2200 2500 2200 2500 2500 2200 1690 2110 2200 2500 1690 2200 1930 1690 | 2980 2980 2190 2190 1930 2190 1930 2190 2190 1820 1500 2030 1930 2190 1500 1930 1500 | 2650 2650 2020 2020 1820 2020 1820 2020 2020 1820 1440 1950 1820 2020 1440 1820 1440 | 2320 2320 1830 1830 1650 1830 1650 1830 1830 1650 1300 1770 1650 1830 1300 1650 1300 | 1880 1880 1750 1750 1580 1750 1580 1750 1750 1580 1250 1700 1580 1750 1250 1580 1250 | 3500 | 5500 (M.../FS) 6500 (S...) | 10 |



RR310 .. i ..

I

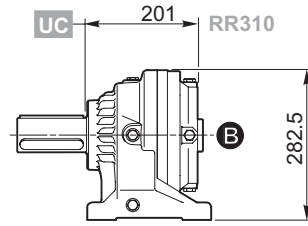
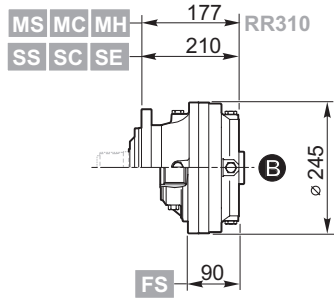

D

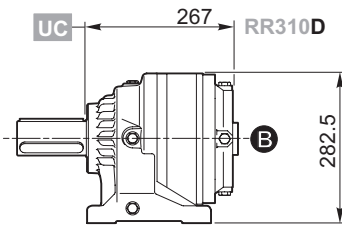
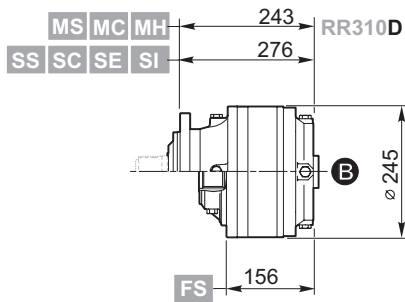

T

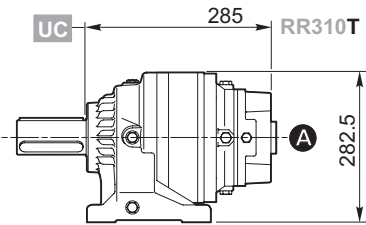
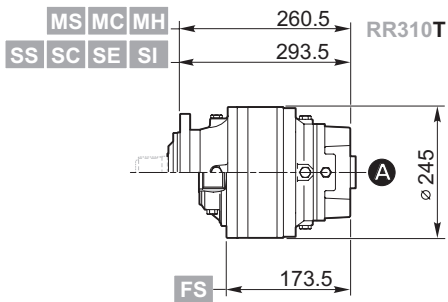

Q

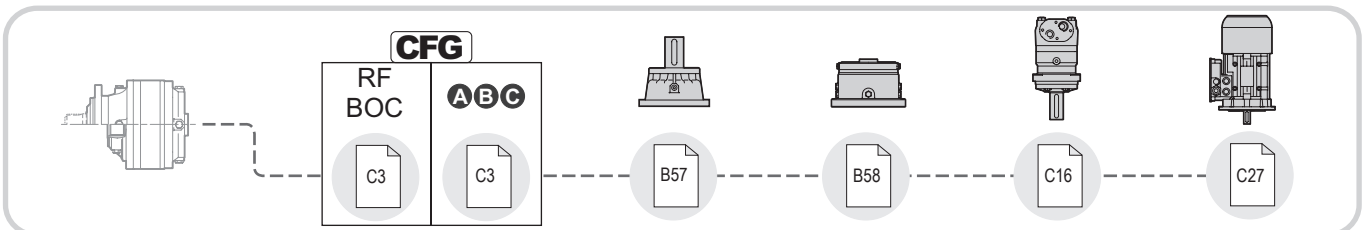
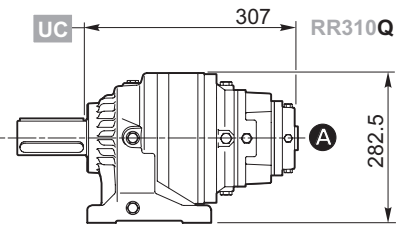
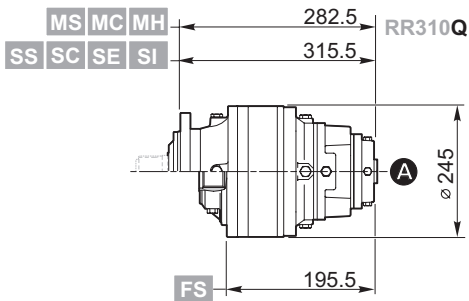

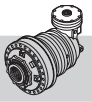

RA310 .. i ..

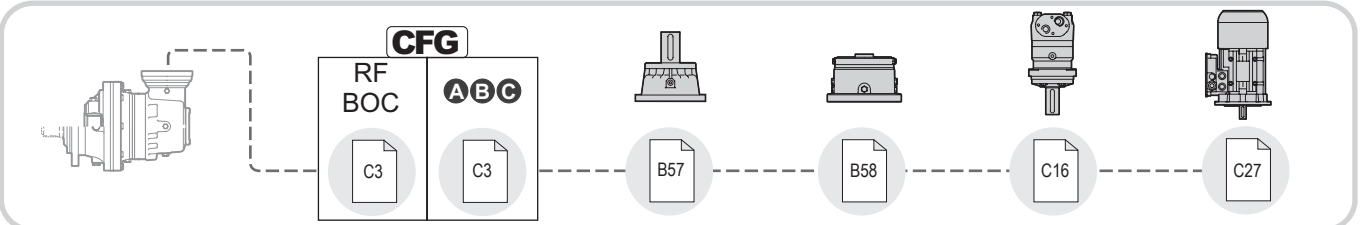
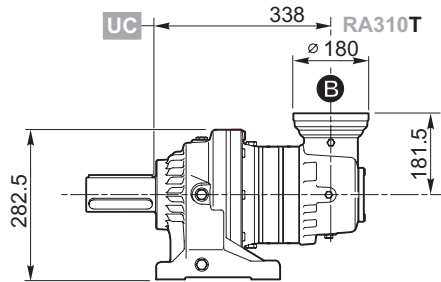
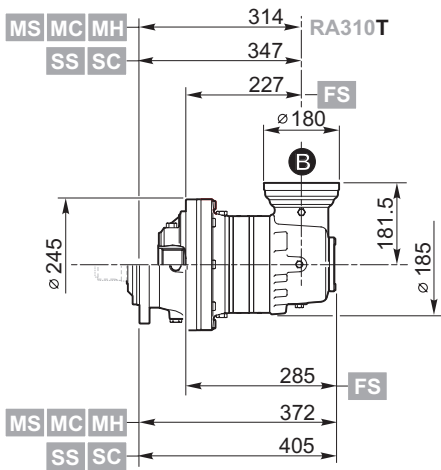
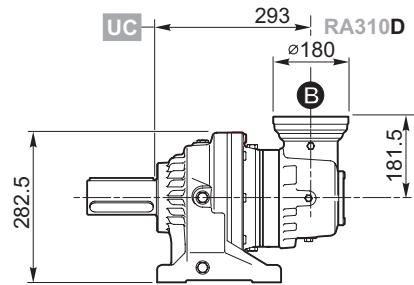
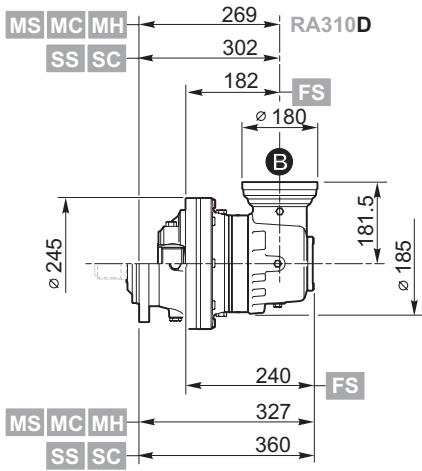
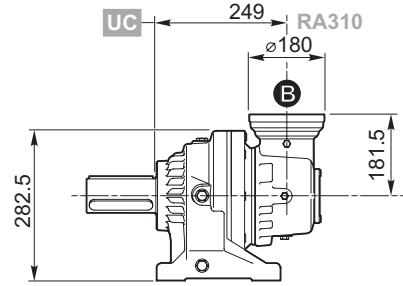
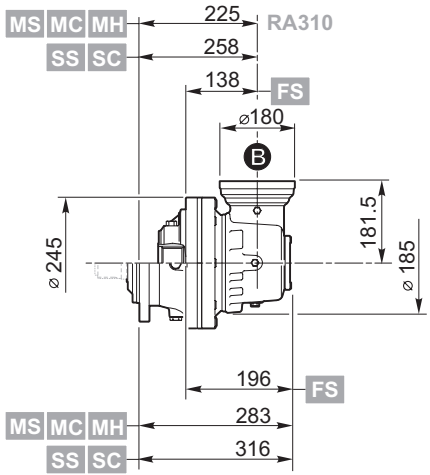

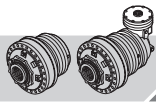

310

IT EN DE FR ES PT

RR310
RA310

- MS
- MC
- MH

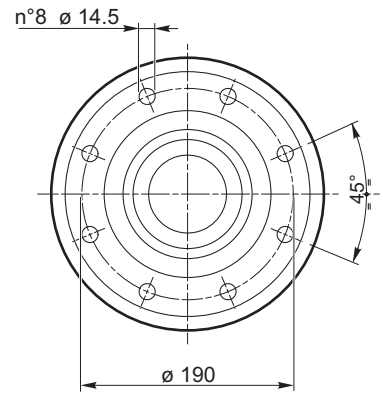
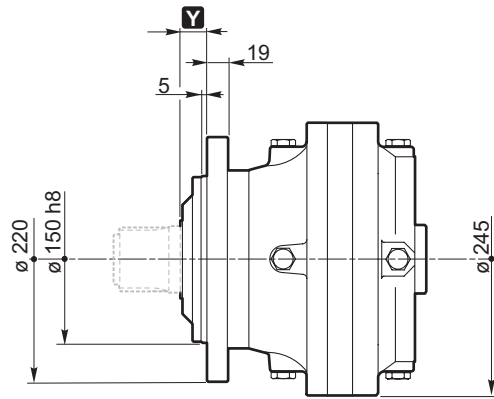

- SS
- SC
- SE

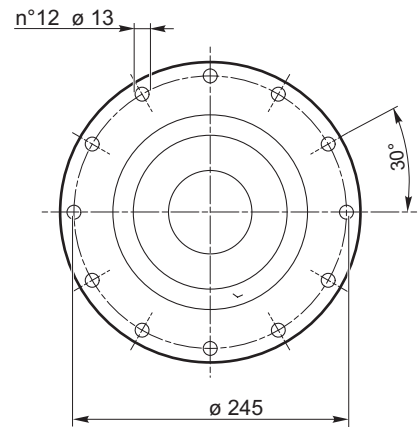
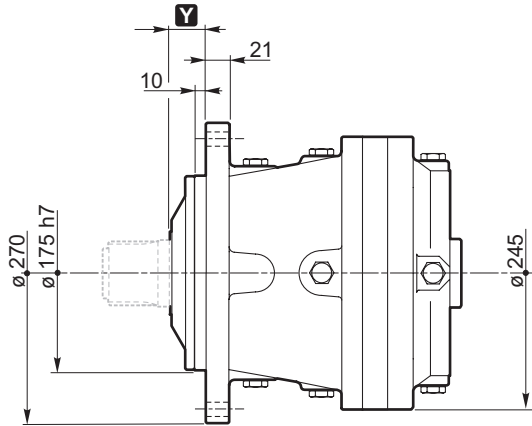

- UC

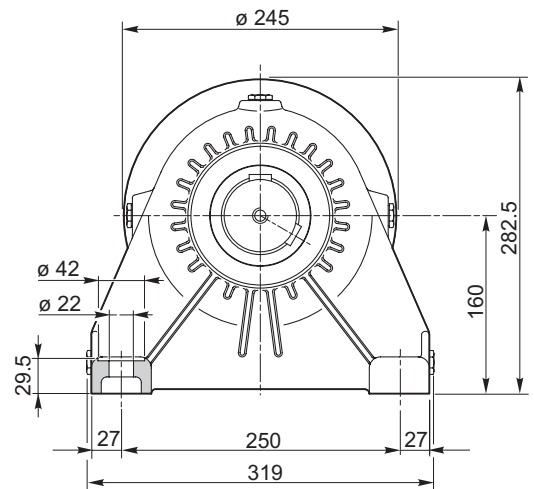
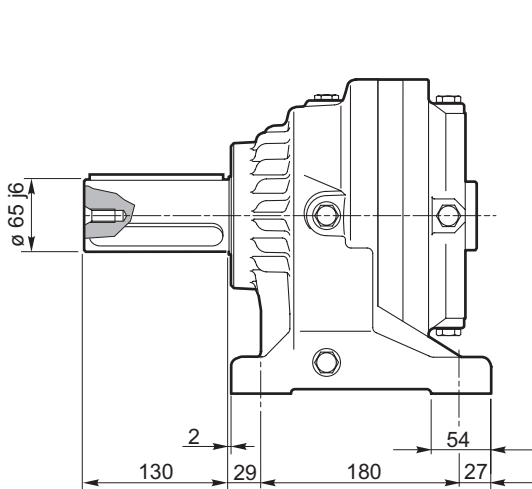

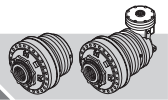

MS

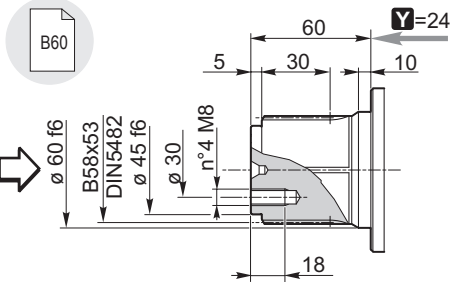
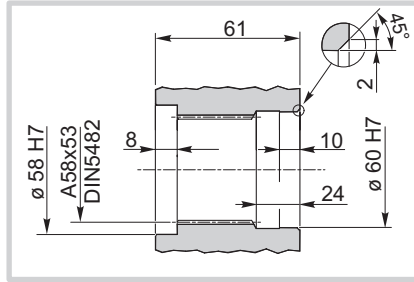
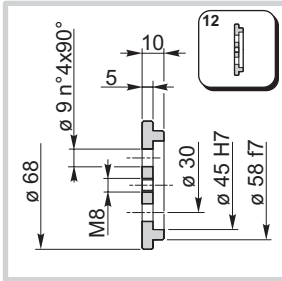

SS

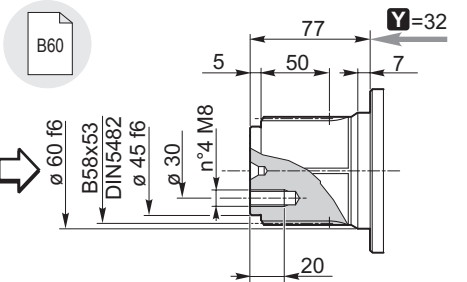
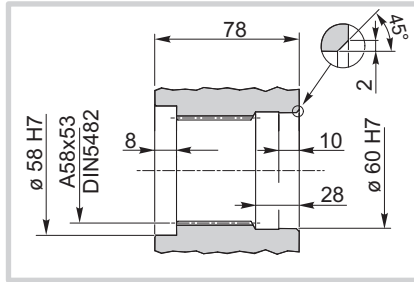

MC
SC
UC

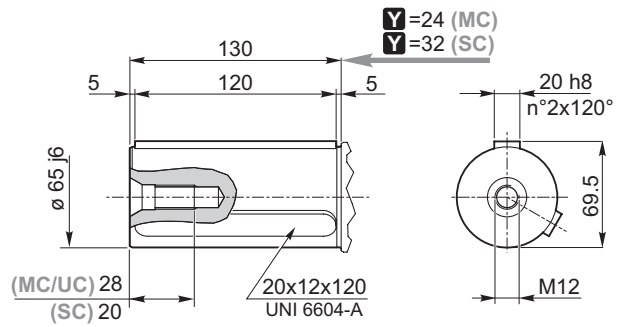
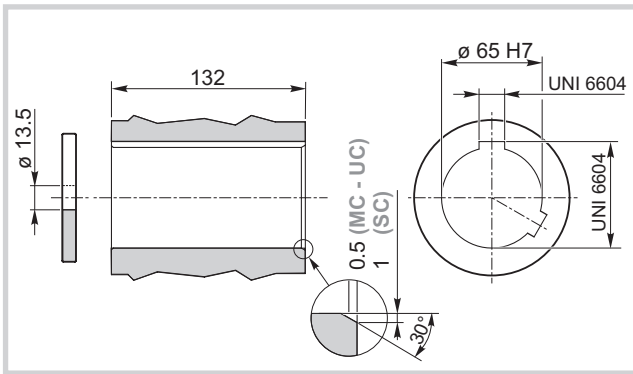

MH

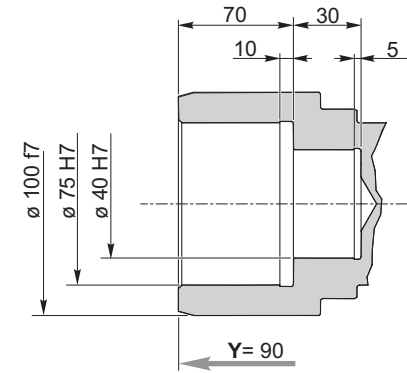
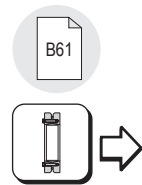
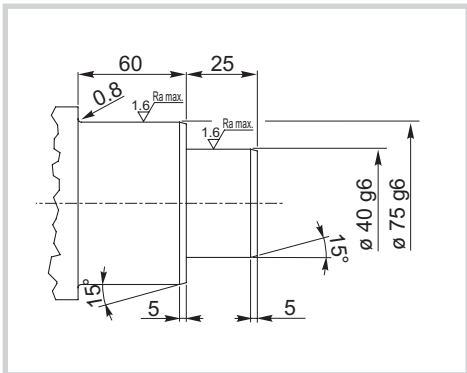

SE

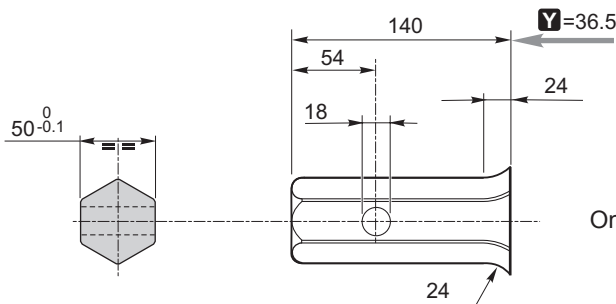

Only for RR310

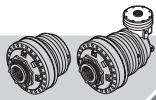

310

IT EN DEFRES PT

RR310 .. i ..

SI

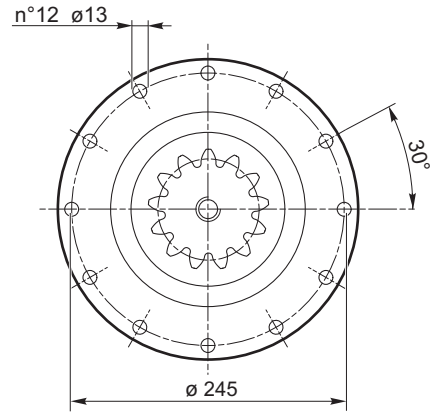
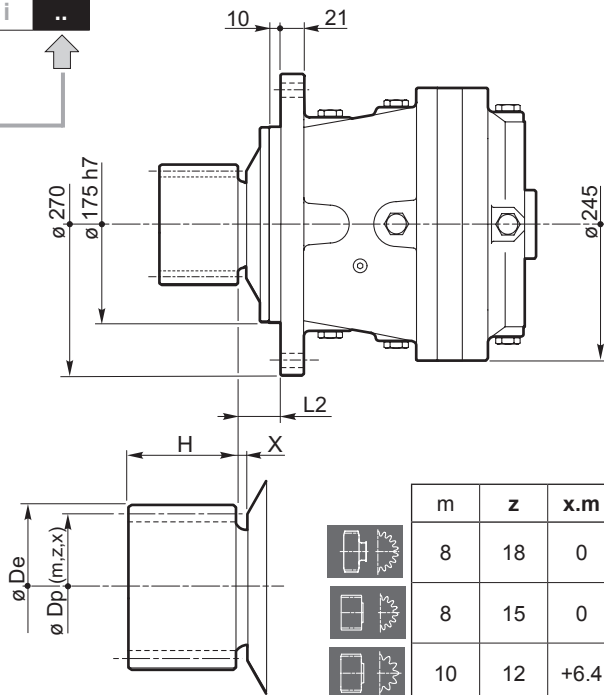

| m | z | x.m | H | Dp | De | L2 | X | code | |
|----|----|------|----|-----|-----|----|------|--------|----------|
| 8 | 18 | 0 | 60 | 144 | 160 | 59 | 28.5 | 03-325 | 154F2898 |
| 8 | 15 | 0 | 80 | 120 | 136 | 36 | 5.5 | 03-500 | 154F2899 |
| 10 | 12 | +6.4 | 80 | 120 | 149 | 40 | 9.5 | 03-579 | 154F5466 |

RR310
RA310 .. i FS

FS

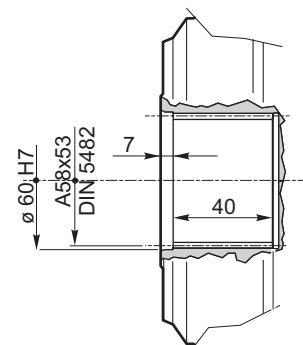
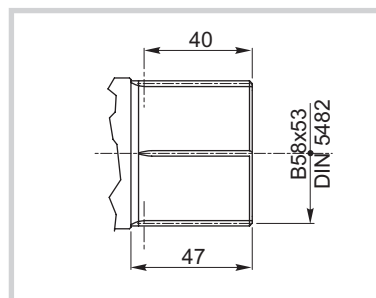
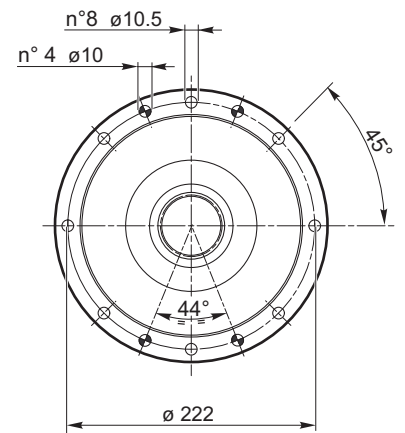
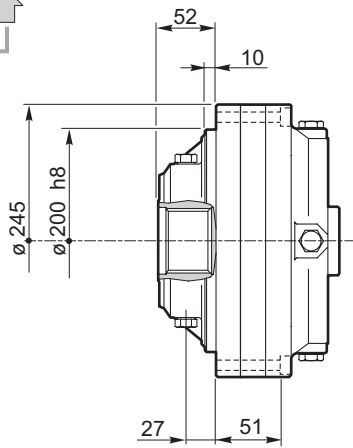

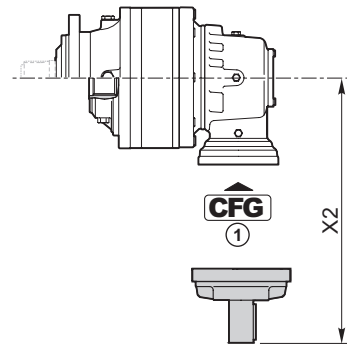
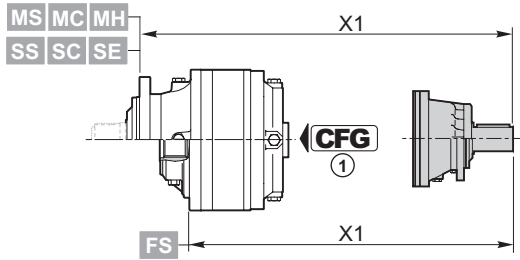
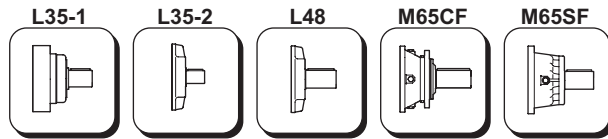
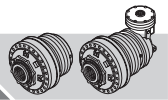

| | CFG ① | | code | X1 |
|---------------|-----------------|--------------|------------|--|
| RR310 | RF | M65SF | 154B4249 | 361.5 (M...) 274.5 (FS) 394.5 (S...) |
| | RF | M65CF | 154-2407 | 384.5 (M...) 297.5 (FS) 417.5 (S...) |
| | BOC | L48 | 154B3989 | 298.5 (M...) 211.5 (FS) 331.5 (S...) |
| RR310D | BOC | L35-2 | 154-2190M1 | 332.5 (M...) 245.5 (FS) 365.5 (S...) |
| RR310T | RF | L35-1 | 154B4054 | 348.5 (M...) 261.5 (FS) 381.5 (S...) |
| RR310Q | RF | L35-1 | 154B4054M1 | 370.5 (M...) 283.5 (FS) 403.5 (S...) |

| | CFG ① | | code | X2 |
|---------------|-----------------|--------------|------------|-------|
| RA310 | BOC | L35-2 | 154-2190M1 | 270.5 |
| RA310D | BOC | L35-2 | 154-2190M1 | 270.5 |
| RA310T | BOC | L35-2 | 154-2190M1 | 270.5 |

| CFG | |
|------------|--|
| RF | |
| BOC | |
| A | |
| B | |
| C | |



310

IT EN DE FR ES PT

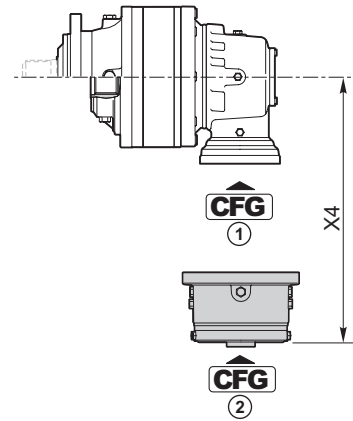
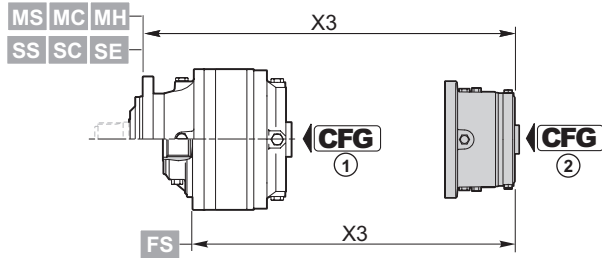
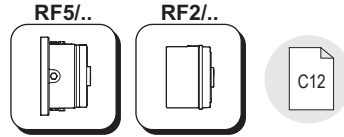

| RF5/.. | CFG ① | T _f [Nm] | CFG ② | | | | | | |
|--------|-------|---------------------|----------|--|----|-------------------|-------------------|--|----|
| | | | B | | | OMTS 12/24 z16 | OMVS 10/20 z16 | | |
| | | | code | X3 | X4 | code | code | X3 | X4 |
| RR310 | RF | 210 | 154-2872 | 267.5 (M...) 180.5 (FS) 300.5 (S...) | — | 154-2879 | 154-2886 | 271.2 (M...) 184.2 (FS) 304.2 (S...) | — |
| | | 290 | 154-2873 | | | 154-2880 | 154-2887 | | |
| | | 430 | 154-2874 | | | 154-2881 | 154-2888 | | |
| | | 650 | 154-2875 | | | 154-2882 | 154-2889 | | |
| | | 850 | 154-2876 | | | 154-2883 | 154-2890 | | |
| | | 1100 | 154-2877 | | | 154-2884 | 154-2891 | | |
| | | 1300 | 154-2878 | | | 154-2885 | 154-2892 | | |

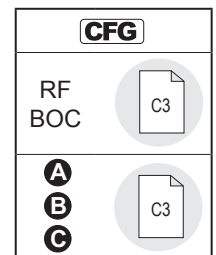



| RF2/.. | CFG ① | T _f [Nm] | CFG ② | | | | | | |
|--------|-------|---------------------|------------|--|-----------------------|------------------------|-----------------------|------------------------|--|
| | | | B | | OMP/OMR SAE A 2B Ø 25 | OMP/OMR SAE A 2B 1" 6B | OMP/OMR SAE A 4B Ø 25 | OMP/OMR SAE A 4B 1" 6B | X3 |
| | | | code | X3 | code | code | code | code | |
| RR310 | RF | 70 | 154-2345 | 240 (M...) 153 (FS) 273 (S...) | 154-2345M10 | 154-2345M11 | 154-2345M16 | 154-2345M17 | 230 (M...) 143 (FS) 263 (S...) |
| | | 140 | 154-2346 | | 154-2346M10 | 154-2346M11 | 154-2346M16 | 154-2346M17 | |
| | | 210 | 154-2347 | | 154-2347M10 | 154-2347M11 | 154-2347M16 | 154-2347M17 | |
| | | 320 | 154-2348 | | 154-2348M10 | 154-2348M11 | 154-2348M16 | 154-2348M17 | |
| | | 430 | 154-2349 | | 154-2349M10 | 154-2349M11 | 154-2349M16 | 154-2349M17 | |
| | | 600 | 154B9186 | | 154B9186M10 | 154B9186M11 | 154B9186M16 | 154B9186M17 | |
| RR310D | RF | 70 | 154-2838M1 | 281.5 (M...) 194.5 (FS) 314.5 (S...) | 154-2863 | 154-2863M11 | 154-2635 | 154-2635M11 | 271.5 (M...) 184.5 (FS) 304.5 (S...) |
| | | 140 | 154-2839M1 | | 154-2864 | 154-2864M11 | 154-2636 | 154-2636M11 | |
| | | 210 | 154-2840M1 | | 154-2865 | 154-2865M11 | 154-2637 | 154-2637M11 | |
| | | 320 | 154-2841M1 | | 154-2866 | 154-2866M11 | 154-2638 | 154-2638M11 | |
| | | 430 | 154-2842M1 | | 154-2867 | 154-2867M11 | 154-2639 | 154-2639M11 | |
| | | 600 | 154B8962M1 | | 154B9665 | 154B9665M11 | 154B9666 | 154B9666M11 | |

| | CFG ① | T _f [Nm] | CFG ② | | | | | | |
|--------|-------|---------------------|------------|--|-----------------------|------------------------|-----------------------|------------------------|--|
| | | | A | | OMP/OMR SAE A 2B Ø 25 | OMP/OMR SAE A 2B 1" 6B | OMP/OMR SAE A 4B Ø 25 | OMP/OMR SAE A 4B 1" 6B | X3 |
| | | | code | X3 | code | code | code | code | |
| RR310T | RF | 70 | 154-2832M1 | 326.5 (M...) 240 (FS) 359.5 (S...) | 154-2858M1 | 154-2858M5 | | | 322 (M...) 235 (FS) 355 (S...) |
| | | 140 | 154-2833M1 | | 154-2859M1 | 154-2859M5 | | | |
| | | 210 | 154-2834M1 | | 154-2860M1 | 154-2860M5 | | | |
| | | 320 | 154-2836M1 | | 154-2861M1 | 154-2861M5 | | | |
| | | 430 | 154-2837M1 | | 154-2862M1 | 154-2862M5 | | | |
| | | 600 | 154B8959M1 | | 154B9663M1 | 154B9663M5 | | | |
| RR310Q | RF | 70 | 154-2832M3 | 348.5 (M...) 262 (FS) 381.5 (S...) | 154-2858M3 | 154-2858M7 | | | 344.5 (M...) 257.5 (FS) 377.5 (S...) |
| | | 140 | 154-2833M3 | | 154-2859M3 | 154-2859M7 | | | |
| | | 210 | 154-2834M3 | | 154-2860M3 | 154-2860M7 | | | |
| | | 320 | 154-2836M3 | | 154-2861M3 | 154-2861M7 | | | |
| | | 430 | 154-2837M3 | | 154-2862M3 | 154-2862M7 | | | |
| | | 600 | 154B8959M3 | | 154B9663M3 | 154B9663M7 | | | |

| | CFG ① | T _f [Nm] | CFG ② | | | | | | |
|--------|-------|---------------------|-------------|-------|-----------------------|------------------------|-----------------------|------------------------|-------|
| | | | B | | OMP/OMR SAE A 2B Ø 25 | OMP/OMR SAE A 2B 1" 6B | OMP/OMR SAE A 4B Ø 25 | OMP/OMR SAE A 4B 1" 6B | X4 |
| | | | code | X4 | code | code | code | code | |
| RA310 | RF | 70 | 154-2838M12 | 223.8 | 154-2863M12 | 154-2863M13 | 154-2635M12 | | 213.8 |
| | | 140 | 154-2839M12 | | 154-2864M12 | 154-2864M13 | 154-2636M12 | | |
| | | 210 | 154-2840M12 | | 154-2865M12 | 154-2865M13 | 154-2637M12 | | |
| | | 320 | 154-2841M12 | | 154-2866M12 | 154-2866M13 | 154-2638M12 | | |
| | | 430 | 154-2842M12 | | 154-2867M12 | 154-2867M13 | 154-2639M12 | | |
| | | 600 | 154B8962M12 | | 154B9665M12 | 154B9665M13 | 154B9666M12 | | |
| RA310D | RF | 70 | 154-2838M12 | 223.8 | 154-2863M12 | 154-2863M13 | 154-2635M12 | | 213.8 |
| | | 140 | 154-2839M12 | | 154-2864M12 | 154-2864M13 | 154-2636M12 | | |
| | | 210 | 154-2840M12 | | 154-2865M12 | 154-2865M13 | 154-2637M12 | | |
| | | 320 | 154-2841M12 | | 154-2866M12 | 154-2866M13 | 154-2638M12 | | |
| | | 430 | 154-2842M12 | | 154-2867M12 | 154-2867M13 | 154-2639M12 | | |
| | | 600 | 154B8962M12 | | 154B9665M12 | 154B9665M13 | 154B9666M12 | | |
| RA310T | RF | 70 | 154-2838M12 | 223.8 | 154-2863M12 | 154-2863M13 | 154-2635M12 | | 213.8 |
| | | 140 | 154-2839M12 | | 154-2864M12 | 154-2864M13 | 154-2636M12 | | |
| | | 210 | 154-2840M12 | | 154-2865M12 | 154-2865M13 | 154-2637M12 | | |
| | | 320 | 154-2841M12 | | 154-2866M12 | 154-2866M13 | 154-2638M12 | | |
| | | 430 | 154-2842M12 | | 154-2867M12 | 154-2867M13 | 154-2639M12 | | |
| | | 600 | 154B8962M12 | | 154B9665M12 | 154B9665M13 | 154B9666M12 | | |

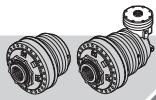

12
Kg 0.2

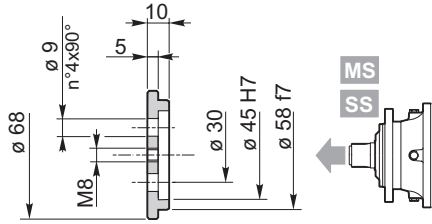

154-3061

Materiale / Material / Material / Matériau / Material / Material:
Acciaio / Steel / Stahl / Acier / Acero / Aço
C40 EN 10083-1 (1.1186)

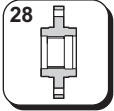

28

Materiale / Material / Material / Matériau / Material / Material: **Acciaio / Steel / Stahl / Acier / Acero / Aço EN 10083-1-C40 (1.1186)**

Trattamento termico:
 Tempra ad induzione secondo UNI 10932 su scanalato interno
Heat treatment:
 Induction hardening according to UNI 10932 on internal spline
Wärmebehandlung:
 Induktionshärtung nach UNI 10932 an interner Nut

Traitement thermique :
 Trempe par induction conformément à la norme UNI 10932 sur cannelé interne
Tratamiento térmico:
 Temple por inducción según UNI 10932 en acanalado interno
Tratamento térmico:
 Tempera por indução segundo UNI 10932 sobre ranhuras internas

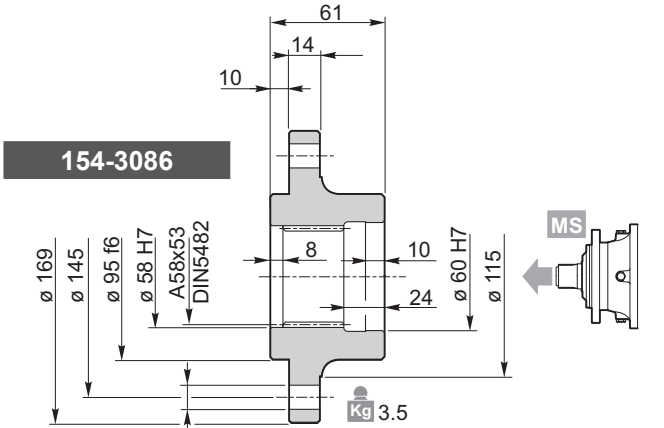

154-3086

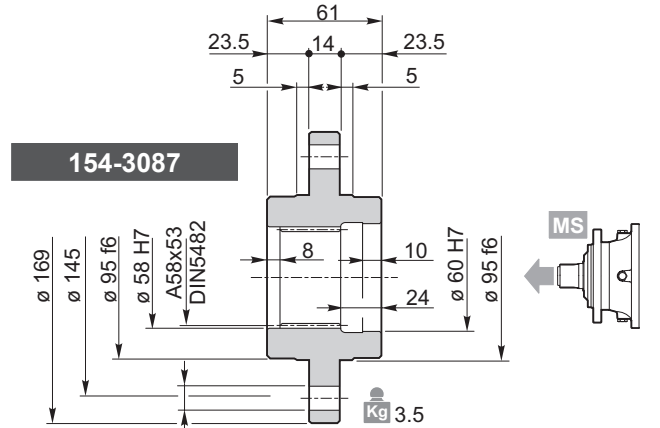

154-3087

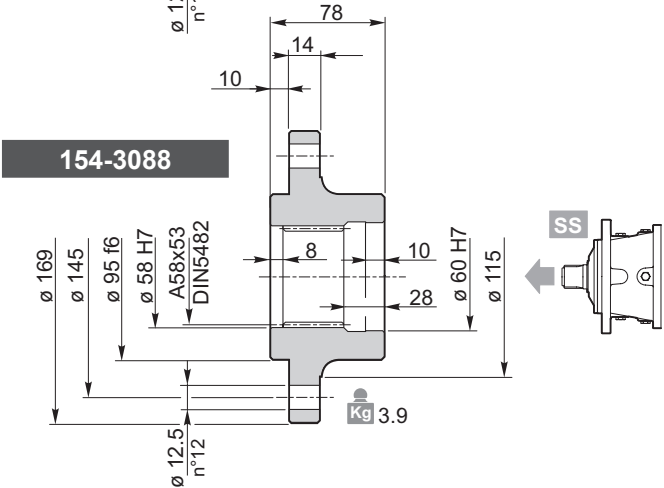

154-3088

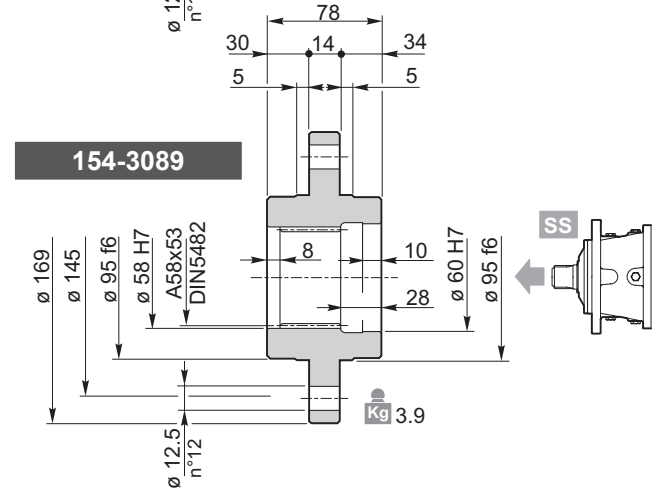

154-3089



29

Materiale / Material / Material / Matériau / Material / Material: **Acciaio / Steel / Stahl / Acier / Acero / Aço 39NiCrMo3 UNI 7845 (1.6511)**

Trattamento termico:
 Tempra ad induzione secondo UNI 10932 su scanalato interno
Heat treatment:
 Induction hardening according to UNI 10932 on internal spline
Wärmebehandlung:
 Induktionshärtung nach UNI 10932 an interner Nut

Traitement thermique :
 Trempe par induction conformément à la norme UNI 10932 sur cannelé interne
Tratamiento térmico:
 Temple por inducción según UNI 10932 en acanalado interno
Tratamento térmico:
 Tempera por indução segundo UNI 10932 sobre ranhuras internas

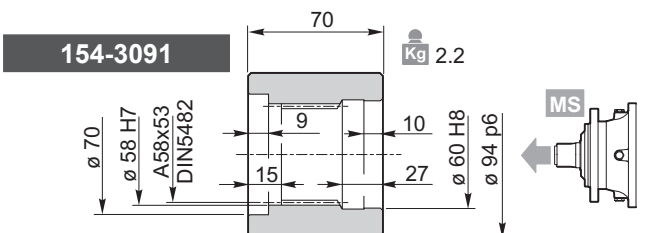

154-3091

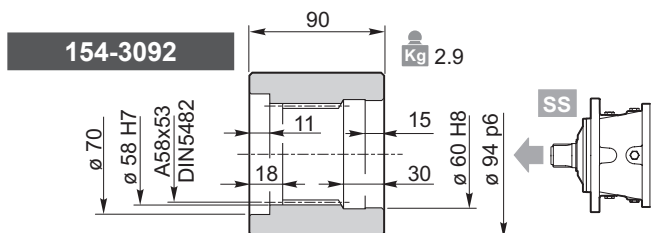

154-3092

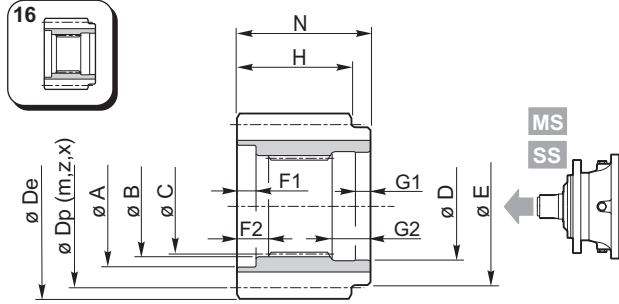
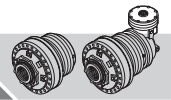

Materiale / Material / Material
Matériau / Material / Material
Acciaio / Steel / Stahl / Acier / Acero / Aço
39NiCrMo3 UNI 7845 (1.6511)

Trattamento termico:
 Tempra ad induzione secondo UNI 10932 su scanalato interno

Heat treatment:
 Induction hardening according to UNI 10932 on internal spline

Wärmebehandlung:
 Induktionshärtung nach UNI 10932 an interner Nut

Traitement thermique:
 Tempra par induction conformément à la norme UNI 10932 sur cannelé interne

Tratamiento térmico:
 Temple por inducción según UNI 10932 en acanalado interno

Tratamento térmico:
 Tempera por indução segundo UNI 10932 sobre ranhuras internas

| | A | B | C | D | E | F1 | F2 | G1 | G2 | N | m | z | x | H | Dp | De | Code |
|----|-------|-------------------|-------------------|-------|----|----|----|----|----|----|-----|----|--------|-----|-----|----------|----------|
| MS | 70 | 58 H7 | DIN5482 A58x53 | 60 H7 | 72 | 7 | 13 | 12 | 27 | 68 | 4.5 | 18 | 0.4444 | 65 | 81 | 93 | 154-3106 |
| | 70 | 58 H7 | DIN5482 A58x53 | 60 H7 | 68 | 7 | 13 | 10 | 27 | 68 | 5 | 17 | 0.4 | 65 | 85 | 98 | 154-2287 |
| | 70 | 58 H7 | DIN5482 A58x53 | 60 H7 | 68 | 7 | 13 | 10 | 27 | 68 | 5 | 19 | 0 | 65 | 95 | 104 | 154-2286 |
| | 70 | 58 H7 | DIN5482 A58x53 | 60 H7 | 75 | 7 | 13 | 12 | 27 | 68 | 6 | 14 | 0.5 | 65 | 84 | 101.5 | 154-3082 |
| | 70 | 58 H7 | DIN5482 A58x53 | 60 H7 | 68 | 7 | 13 | 10 | 27 | 68 | 6 | 15 | 0.25 | 65 | 90 | 103 | 154-3107 |
| | 70 | 58 H7 | DIN5482 A58x53 | 60 H7 | 68 | 7 | 13 | 10 | 27 | 68 | 6 | 16 | 0.25 | 65 | 96 | 109 | 154-3245 |
| | 70 | 58 H7 | DIN5482 A58x53 | 60 H7 | 78 | 7 | 13 | 12 | 27 | 68 | 8 | 12 | 0.5 | 65 | 96 | 118 | 154-3074 |
| | 70 | 58 H7 | DIN5482 A58x53 | 60 H7 | 68 | 7 | 13 | 10 | 27 | 68 | 8 | 14 | 0 | 65 | 112 | 126 | 154-3250 |
| | 70 | 58 H7 | DIN5482 A58x53 | 60 H7 | 78 | 7 | 13 | 12 | 27 | 68 | 8 | 15 | 0 | 65 | 120 | 136 | 154-3246 |
| | 70 | 58 H7 | DIN5482 A58x53 | 60 H7 | 68 | 7 | 13 | 10 | 27 | 68 | 8 | 15 | 0.25 | 65 | 120 | 138 | 154-3235 |
| | 70 | 58 H7 | DIN5482 A58x53 | 60 H7 | 78 | 7 | 13 | 12 | 27 | 68 | 8 | 18 | 0 | 65 | 144 | 158 | 154-3103 |
| | 70 | 58 H7 | DIN5482 A58x53 | 60 H7 | 78 | 7 | 13 | 12 | 27 | 68 | 10 | 10 | 0.25 | 65 | 100 | 124.5 | 154-3075 |
| | 70 | 58 H7 | DIN5482 A58x53 | 60 H7 | 78 | 7 | 13 | 12 | 27 | 68 | 10 | 12 | 0.475 | 65 | 120 | 149.5 | 154-3105 |
| | 70 | 58 H7 | DIN5482 A58x53 | 60 H7 | 68 | 7 | 13 | 10 | 27 | 68 | 10 | 15 | 0 | 65 | 150 | 167 | 154-3248 |
| SS | 70 | 58 H7 | DIN5482 A58x53 | 60 H7 | 78 | 5 | 12 | 12 | 30 | 84 | 6 | 14 | 0.5 | 80 | 84 | 101.5 | 154-3238 |
| | 70 | 58 H7 | DIN5482 A58x53 | 60 H7 | 78 | 5 | 12 | 12 | 30 | 84 | 6 | 16 | 0.4167 | 80 | 96 | 111 | 154-3234 |
| | 70 | 58 H7 | DIN5482 A58x53 | 60 H7 | 78 | 5 | 12 | 12 | 30 | 84 | 6 | 19 | 0 | 80 | 114 | 126 | 154-2706 |
| | 70 | 58 H7 | DIN5482 A58x53 | 60 H7 | 78 | 6 | 12 | 10 | 30 | 84 | 6 | 24 | 0 | 80 | 144 | 154 | 154-3101 |
| | 70 | 58 H7 | DIN5482 A58x53 | 60 H7 | 78 | 5 | 12 | 12 | 30 | 84 | 7 | 13 | 0.5 | 80 | 91 | 109 | 154-3038 |
| | 70 | 58 H7 | DIN5482 A58x53 | 60 H7 | 78 | 5 | 12 | 12 | 30 | 84 | 8 | 12 | 0.5 | 80 | 96 | 118 | 154-3076 |
| | 70 | 58 H7 | DIN5482 A58x53 | 60 H7 | 78 | 5 | 12 | 12 | 30 | 84 | 8 | 13 | 0.35 | 80 | 104 | 125.6 | 154-3236 |
| | 70 | 58 H7 | DIN5482 A58x53 | 60 H7 | 78 | 5 | 12 | 12 | 30 | 84 | 8 | 15 | 0.25 | 80 | 120 | 138 | 154-2288 |
| | 70 | 58 H7 | DIN5482 A58x53 | 60 H7 | 78 | 5 | 12 | 12 | 30 | 84 | 8 | 18 | 0 | 80 | 144 | 158 | 154-2716 |
| | 70 | 58 H7 | DIN5482 A58x53 | 60 H7 | 78 | 5 | 12 | 12 | 30 | 84 | 10 | 10 | 0.25 | 80 | 100 | 124.5 | 154-3067 |
| | 70 | 58 H7 | DIN5482 A58x53 | 60 H7 | 78 | 5 | 12 | 12 | 30 | 84 | 10 | 12 | 0.475 | 80 | 120 | 149.5 | 154-3077 |
| | 70 | 58 H7 | DIN5482 A58x53 | 60 H7 | 78 | 5 | 12 | 12 | 30 | 84 | 10 | 13 | 0 | 80 | 130 | 148 | 154-3070 |
| | 70 | 58 H7 | DIN5482 A58x53 | 60 H7 | 78 | 5 | 12 | 12 | 30 | 84 | 10 | 14 | 0.4 | 80 | 140 | 164 | 154-2289 |
| | 70 | 58 H7 | DIN5482 A58x53 | 60 H7 | 78 | 5 | 12 | 12 | 30 | 84 | 10 | 15 | 0 | 80 | 150 | 169 | 154-3078 |
| 70 | 58 H7 | DIN5482 A58x53 | 60 H7 | 78 | 5 | 12 | 12 | 30 | 84 | 10 | 16 | 0 | 80 | 160 | 178 | 154-3108 | |

154-3052

Materiale / Materiale / Material
Matériau / Material / Material:
Acciaio / Steel / Stahl / Acier / Acero / Aço
39NiCrMo3 UNI 7845 (1.6511)

154B3090

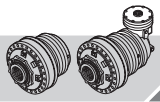

310

IT EN DE FR ES PT

| | | | |
|----|-----|----|-----------|
| RR | 310 | .. | MS |
| RA | | | MC |

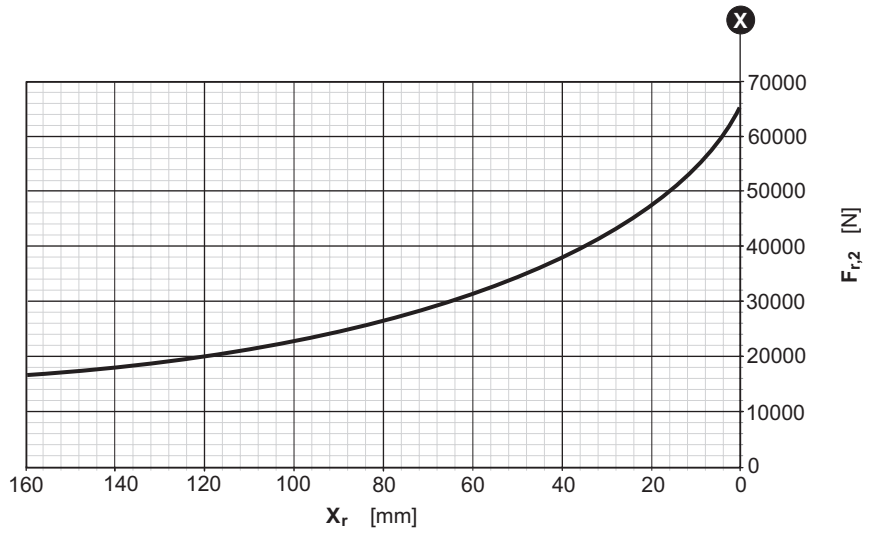
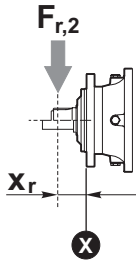

| | | | |
|----|-----|----|-----------|
| RR | 310 | .. | SS |
| RA | | | SC |
| | | | SE |

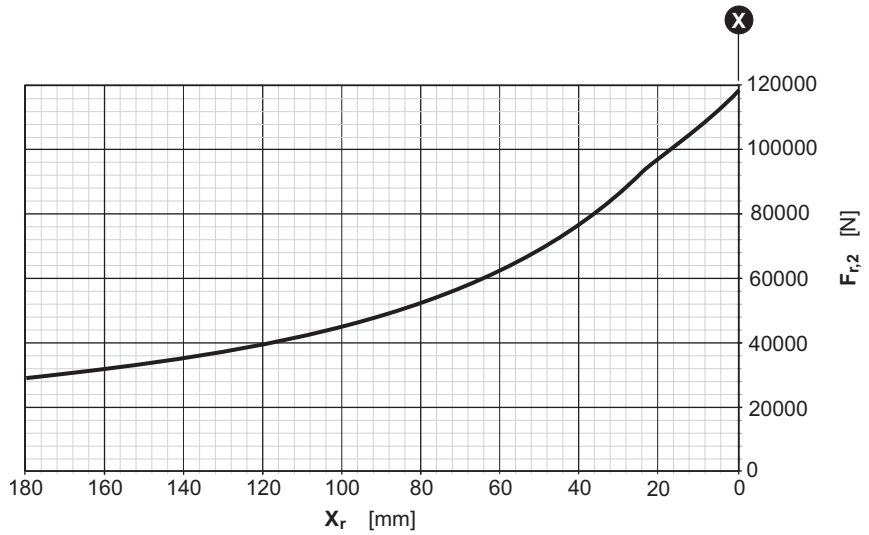
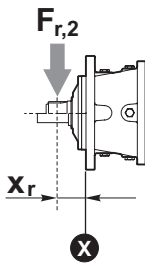

| | | | |
|----|-----|----|-----------|
| RR | 310 | .. | UC |
| RA | | | |

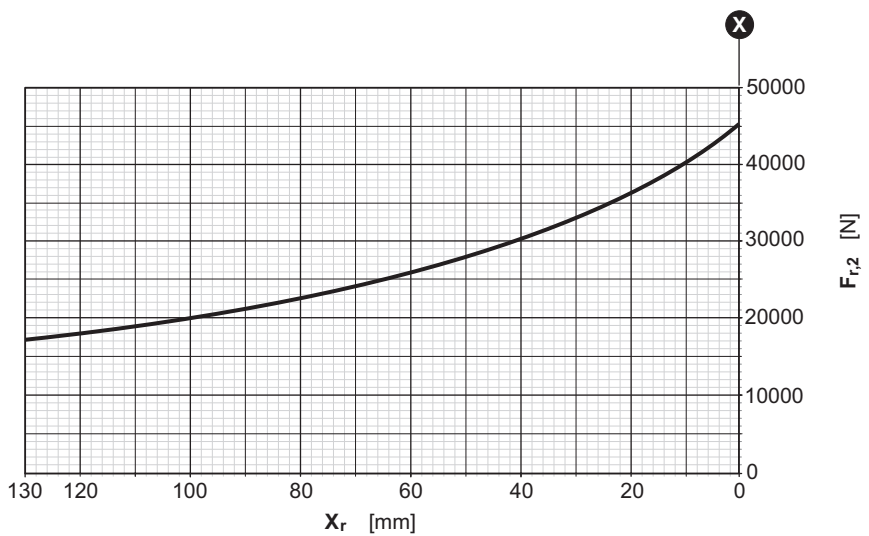
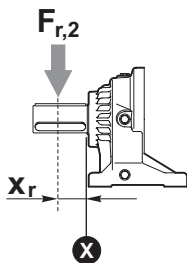

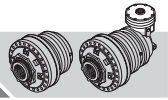

RR 310 .. SI

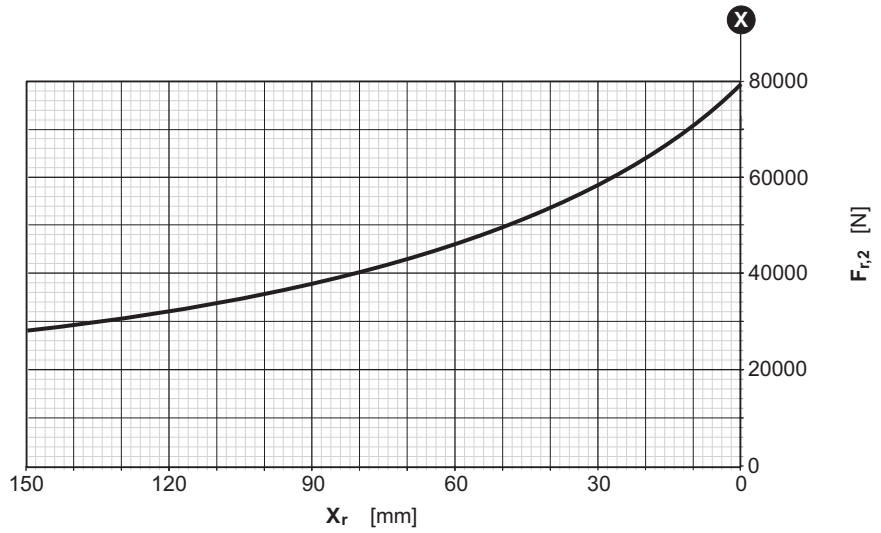
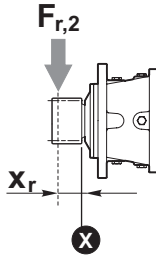

Fattore correttivo $k_{r,2}$ / $k_{r,2}$ Corrective coefficient / Korrekturfaktor $k_{r,2}$
 Facteur correctif $k_{r,2}$ / Factor de corrección $k_{r,2}$ / Fator corretivo $k_{r,2}$

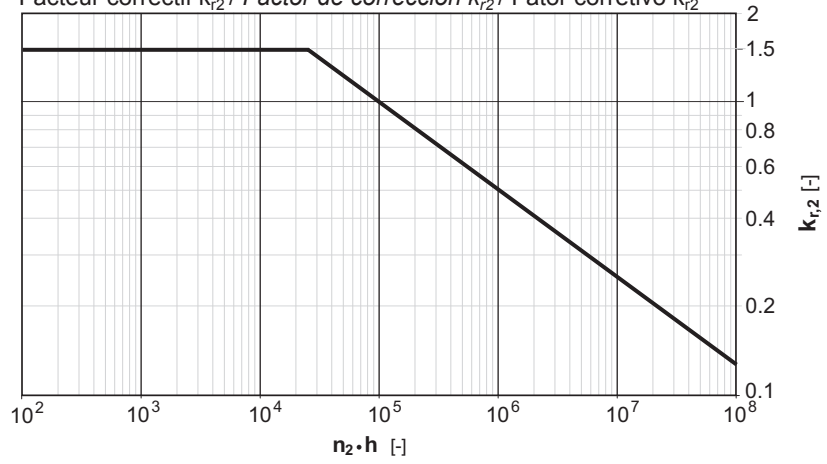



510

IT EN DE FR ES PT

RR510

..

i



| | i | T ₂ [Nm] | | | | | | n _{1max} [min ⁻¹] | T _{2max} [Nm] | P _t [kW] |
|----------------|---------------|-----------------------------|-----------------------------------|---------------------------------|------------------------------|----------------------------------|-------------------------------|---|---------------------------|------------------------|
| | | n ₂ x h | | | | | | | | |
| | 1/... | 10000 (10 ⁴) | 25000 (2.5 · 10 ⁴) | 50000 (5 · 10 ⁴) | 100000 (10 ⁵) | 500000 (5 · 10 ⁵) | 1000000 (10 ⁶) | | | |
| RR510 | 3.40 | 5750 | 5430 | 5290 | 5160 | 4200 | 3410 | 3500 | 7000 (M.../FS) | 21 |
| | 4.00 | 6440 | 5960 | 5360 | 4760 | 4310 | 3810 | | | |
| | 5.00 | 5350 | 4500 | 3960 | 3640 | 3290 | 3160 | | | |
| | 5.80 | 4710 | 3960 | 3480 | 3280 | 2970 | 2840 | | | |
| | 7.00 | 3650 | 3070 | 2720 | 2600 | 2360 | 2260 | | | |
| RR510D | 13.60 | 5750 | 5430 | 5290 | 5160 | 4200 | 3410 | 3500 | 7000 (M.../FS) | 13 |
| | 16.00 | 6440 | 5960 | 5360 | 4760 | 4310 | 3810 | | | |
| | 20.00 | 6440 | 5960 | 5360 | 4760 | 4310 | 3810 | | | |
| | 23.20 | 6440 | 5960 | 5360 | 4760 | 4310 | 3810 | | | |
| | 29.00 | 5350 | 4500 | 3960 | 3640 | 3290 | 3160 | | | |
| | 35.00 | 5350 | 4500 | 3960 | 3640 | 3290 | 3160 | | | |
| | 40.60 | 4710 | 3960 | 3480 | 3280 | 2970 | 2840 | | | |
| | 49.00 | 3650 | 3070 | 2720 | 2600 | 2360 | 2260 | | | |
| RR510T | 65.60 | 6440 | 5960 | 5360 | 4760 | 4310 | 3810 | 3500 | 7000 (M.../FS) | 10 |
| | 82.00 | 6440 | 5960 | 5360 | 4760 | 4310 | 3810 | | | |
| | 95.12 | 6440 | 5960 | 5360 | 4760 | 4310 | 3810 | | | |
| | 115.2 | 6440 | 5960 | 5360 | 4760 | 4310 | 3810 | | | |
| | 144.00 | 6440 | 5960 | 5360 | 4760 | 4310 | 3810 | | | |
| | 167.04 | 6440 | 5960 | 5360 | 4760 | 4310 | 3810 | | | |
| | 208.80 | 5350 | 4500 | 3960 | 3640 | 3290 | 3160 | | | |
| | 252.00 | 5350 | 4500 | 3960 | 3640 | 3290 | 3160 | | | |
| | 292.32 | 4710 | 3960 | 3480 | 3280 | 2970 | 2840 | | | |
| | 352.80 | 3650 | 3070 | 2720 | 2600 | 2360 | 2260 | | | |
| | RR510Q | 381.30 | 6440 | 5960 | 5360 | 4760 | 4310 | | | |
| 442.31 | | 6440 | 5960 | 5360 | 4760 | 4310 | 3810 | | | |
| 509.22 | | 6440 | 5960 | 5360 | 4760 | 4310 | 3810 | | | |
| 584.71 | | 6440 | 5960 | 5360 | 4760 | 4310 | 3810 | | | |
| 669.60 | | 6440 | 5960 | 5360 | 4760 | 4310 | 3810 | | | |
| 715.39 | | 6440 | 5960 | 5360 | 4760 | 4310 | 3810 | | | |
| 776.74 | | 6440 | 5960 | 5360 | 4760 | 4310 | 3810 | | | |
| 894.24 | | 6440 | 5960 | 5360 | 4760 | 4310 | 3810 | | | |
| 1037.32 | | 6440 | 5960 | 5360 | 4760 | 4310 | 3810 | | | |
| 1296.65 | | 5350 | 4500 | 3960 | 3640 | 3290 | 3160 | | | |
| 1564.92 | | 5350 | 4500 | 3960 | 3640 | 3290 | 3160 | | | |
| 1815.31 | | 4710 | 3960 | 3480 | 3280 | 2970 | 2840 | | | |
| 2190.89 | | 3650 | 3070 | 2720 | 2600 | 2360 | 2260 | | | |

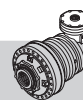

RA510 .. **i**



| i | T ₂ [Nm] | | | | | | n _{1max} [min ⁻¹] | T _{2max} [Nm] | P _t [kW] | |
|---------------|-----------------------------|-----------------------------------|---------------------------------|------------------------------|----------------------------------|-------------------------------|---|---------------------------|---|----|
| | n ₂ x h | | | | | | | | | |
| 1/... | 10000 (10 ⁴) | 25000 (2.5 · 10 ⁴) | 50000 (5 · 10 ⁴) | 100000 (10 ⁵) | 500000 (5 · 10 ⁵) | 1000000 (10 ⁶) | | | | |
| RA510 | 13.60 | 5690 | 5300 | 4680 | 4360 | 3450 | 2800 | 3500 | 7000 (M.../FS) 7500 (S...) | 23 |
| | 16.00 | 6440 | 5960 | 5340 | 4760 | 3870 | 3140 | | | |
| | 20.00 | 5350 | 4500 | 3960 | 3640 | 3290 | 3160 | | | |
| | 23.20 | 4710 | 3960 | 3480 | 3280 | 2970 | 2840 | | | |
| | 28.00 | 3650 | 3070 | 2720 | 2600 | 2360 | 2260 | | | |
| RA510D | 43.79 | 5750 | 5250 | 4990 | 4750 | 3250 | 2640 | 3500 | 7000 (M.../FS) 7500 (S...) | 14 |
| | 51.52 | 6440 | 5960 | 5360 | 4760 | 3640 | 2960 | | | |
| | 64.40 | 6440 | 5960 | 5360 | 4760 | 4260 | 3460 | | | |
| | 74.70 | 6440 | 5960 | 5360 | 4760 | 4310 | 3810 | | | |
| | 93.38 | 5350 | 4500 | 3960 | 3640 | 3290 | 3160 | | | |
| | 112.70 | 5350 | 4500 | 3960 | 3640 | 3290 | 3160 | | | |
| | 130.73 | 4710 | 3960 | 3480 | 3280 | 2970 | 2840 | | | |
| | 157.78 | 3650 | 3070 | 2720 | 2600 | 2360 | 2260 | | | |
| | 164.86 | 4210 | 3900 | 3690 | 3490 | 3060 | 2890 | | | |
| | 170.75 | 4340 | 4030 | 3810 | 3600 | 3160 | 2990 | | | |
| | 198.07 | 4710 | 3960 | 3480 | 3280 | 2970 | 2840 | | | |
| | 206.08 | 5160 | 4500 | 3960 | 3640 | 3290 | 3160 | | | |
| | 239.05 | 4710 | 3960 | 3480 | 3280 | 2970 | 2840 | | | |
| | 288.51 | 3650 | 3070 | 2720 | 2600 | 2360 | 2260 | | | |
| RA510T | 211.23 | 6440 | 5960 | 5360 | 4760 | 4310 | 3810 | 3500 | 7000 (M.../FS) 7500 (S...) | 11 |
| | 264.04 | 6440 | 5960 | 5360 | 4760 | 4310 | 3810 | | | |
| | 306.29 | 6440 | 5960 | 5360 | 4760 | 4310 | 3810 | | | |
| | 370.94 | 6440 | 5960 | 5360 | 4760 | 4310 | 3810 | | | |
| | 463.68 | 6440 | 5960 | 5360 | 4760 | 4310 | 3810 | | | |
| | 537.87 | 6440 | 5960 | 5360 | 4760 | 4310 | 3810 | | | |
| | 672.34 | 5350 | 4500 | 3960 | 3640 | 3290 | 3160 | | | |
| | 811.44 | 5350 | 4500 | 3960 | 3640 | 3290 | 3160 | | | |
| | 941.27 | 4710 | 3960 | 3480 | 3280 | 2970 | 2840 | | | |
| | 1136.02 | 3650 | 3070 | 2720 | 2600 | 2360 | 2260 | | | |
| | 1187.02 | 6050 | 5610 | 5360 | 4760 | 4310 | 3810 | | | |
| | 1229.41 | 5350 | 4500 | 3960 | 3640 | 3290 | 3160 | | | |
| | 1483.78 | 5350 | 4500 | 3960 | 3640 | 3290 | 3160 | | | |
| | 1563.74 | 3650 | 3070 | 2720 | 2600 | 2360 | 2260 | | | |
| | 1721.18 | 4710 | 3960 | 3480 | 3280 | 2970 | 2840 | | | |
| | 2077.29 | 3650 | 3070 | 2720 | 2600 | 2360 | 2260 | | | |



510

IT EN DE FR ES PT

RR510 .. i ..



I

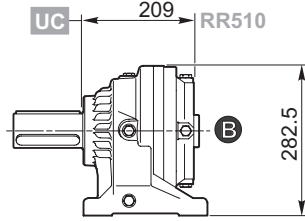
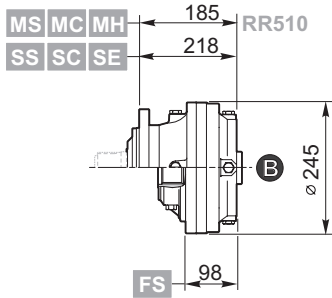

D

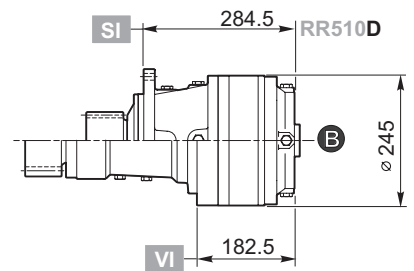
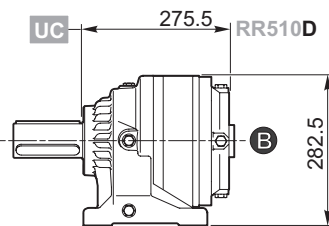
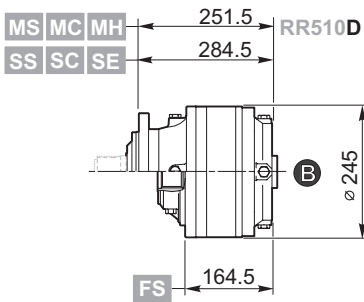

T

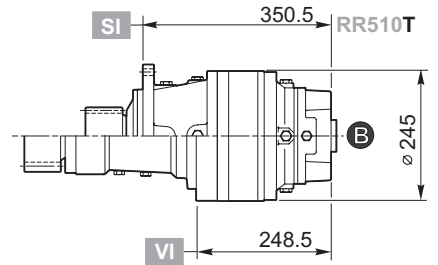
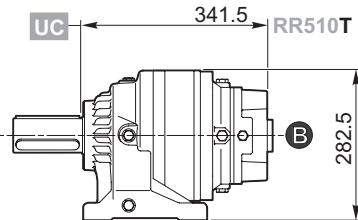
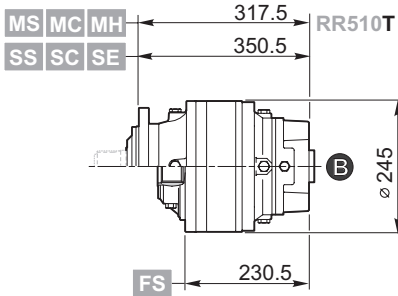

Q

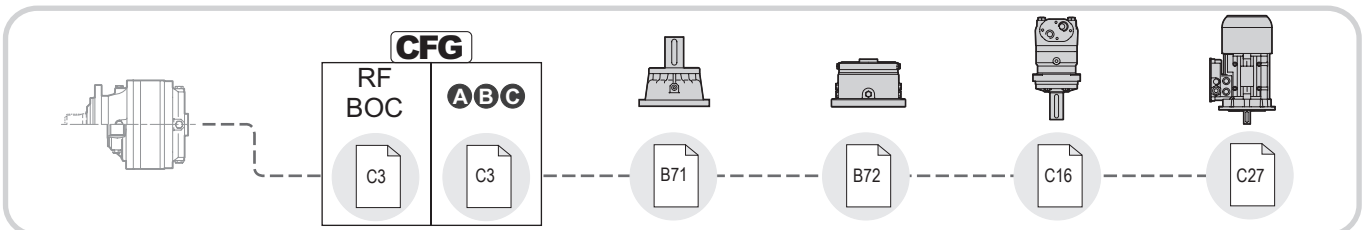
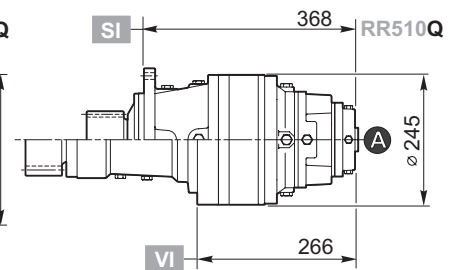
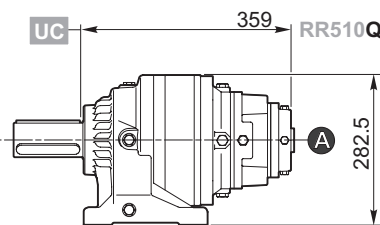
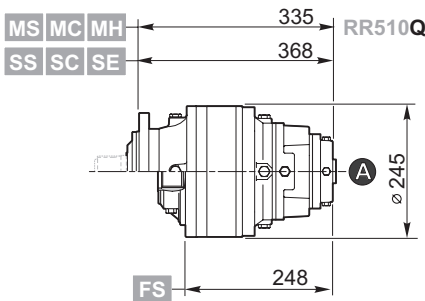

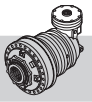

RA510 .. i ..

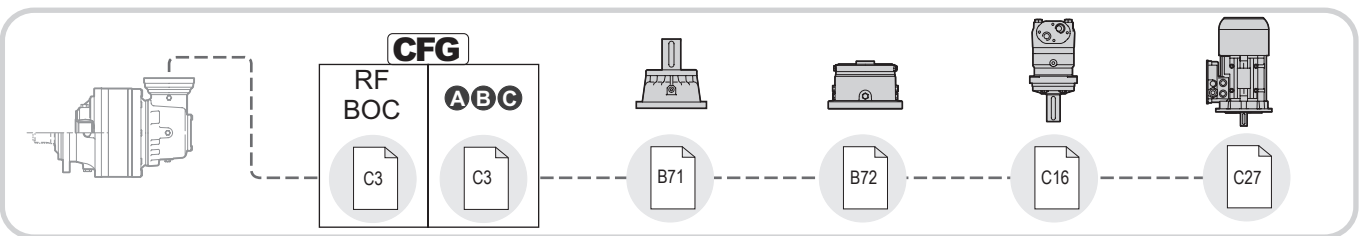
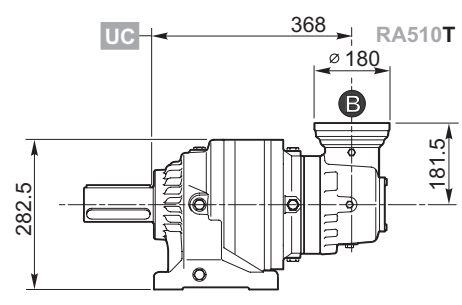
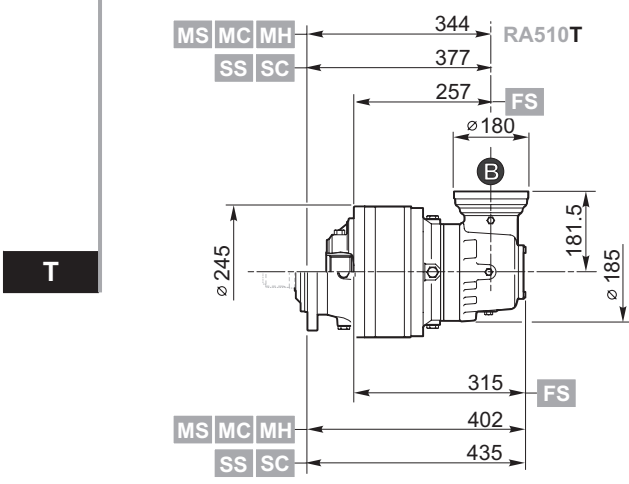
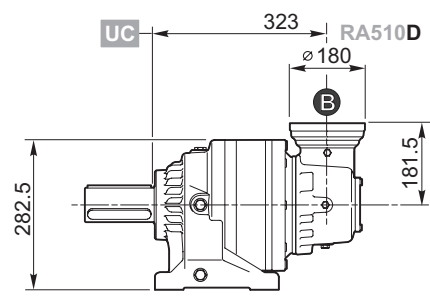
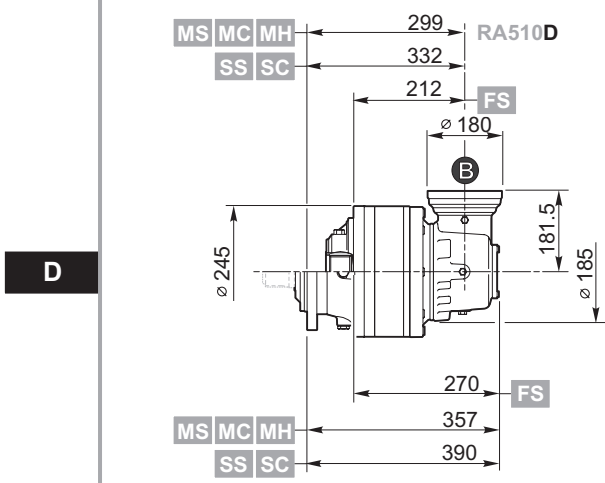
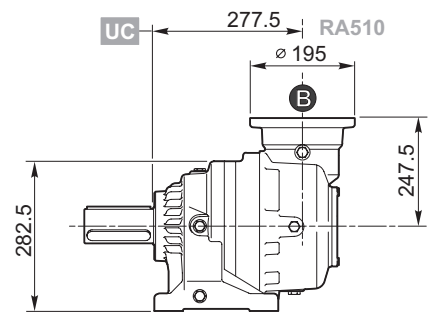
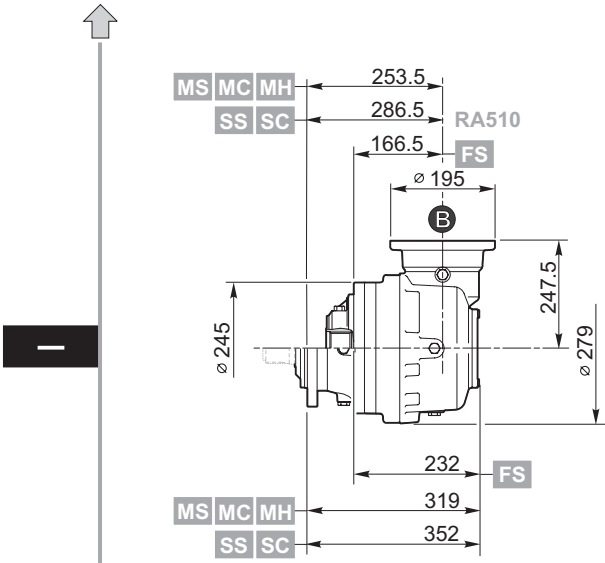

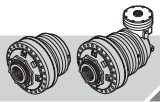







510

IT EN DE FR ES PT

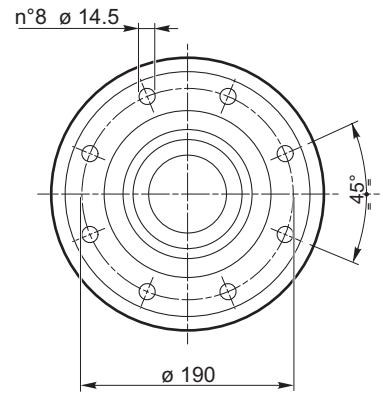
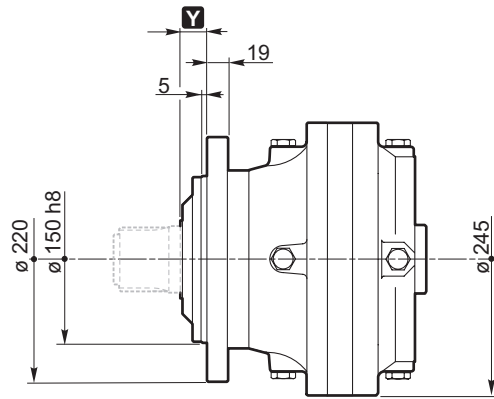
| | | | |
|-------|----|---|----|
| RR510 | .. | i | .. |
| RA510 | .. | | .. |

- MS** 
- MC** 
- MH** 



- SS** 
- SC** 
- SE** 

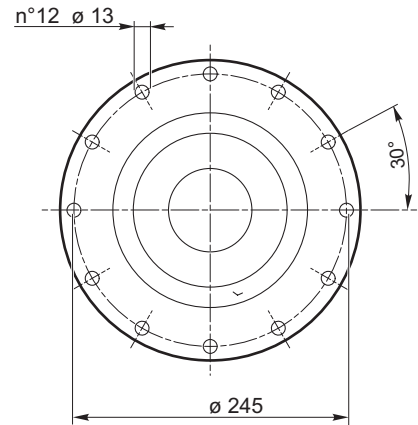
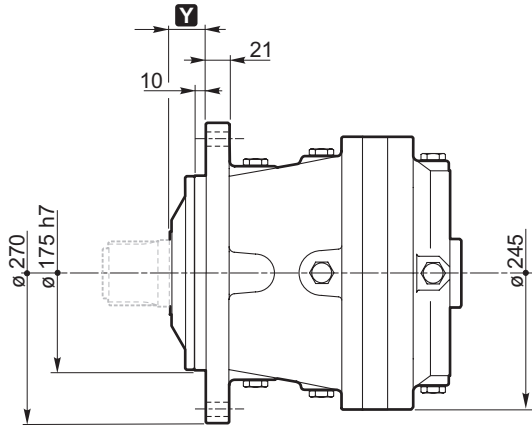

- UC** 

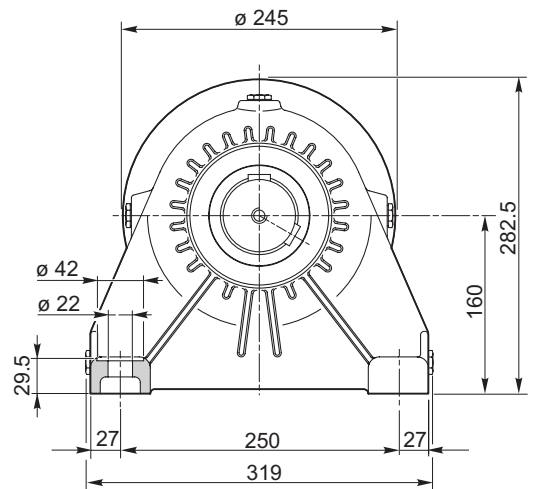
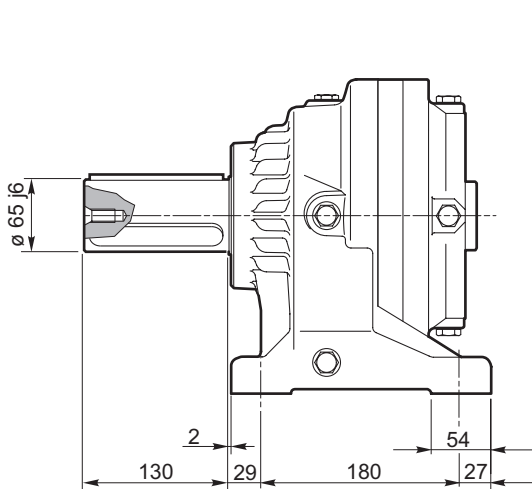

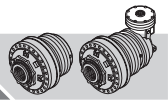

MS

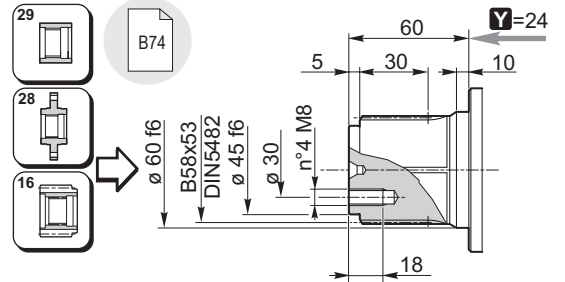
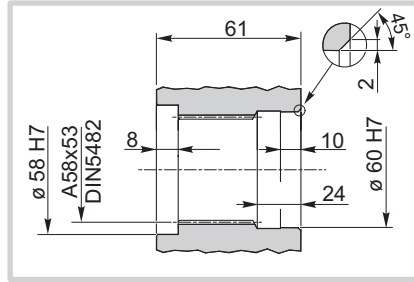
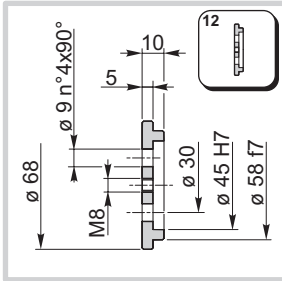

SS

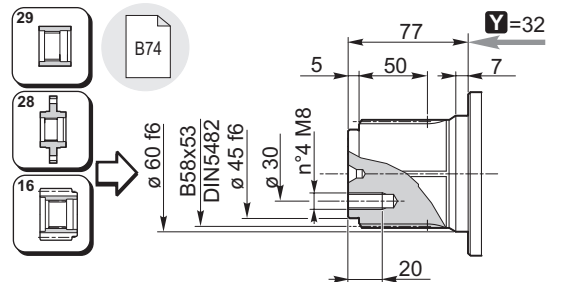
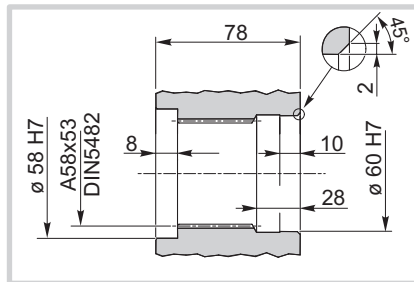

MC
SC
UC

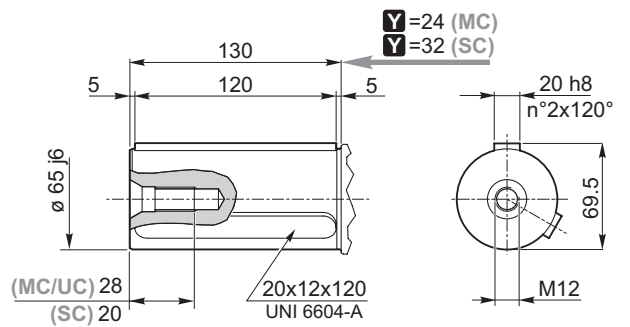
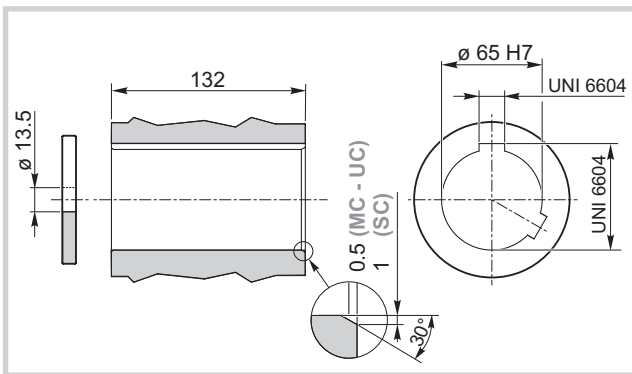

MH

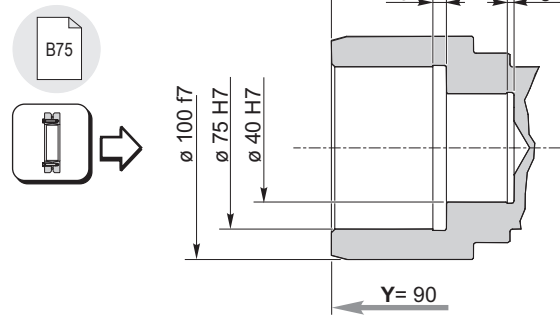
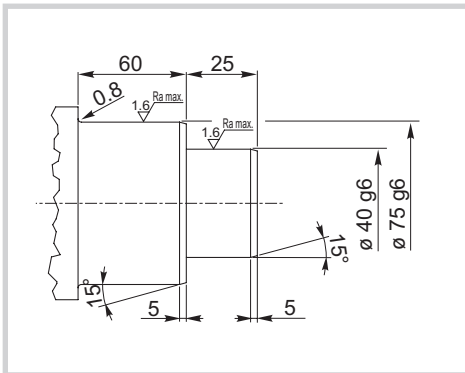

SE

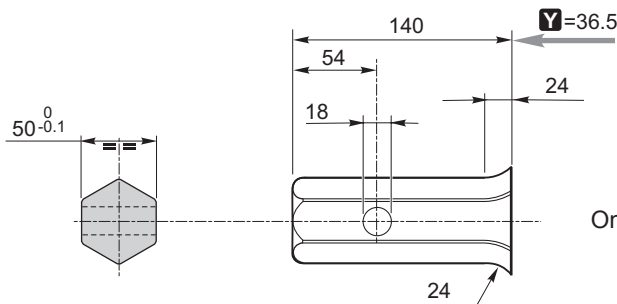

Only for RR510



510

IT EN DEFRES PT

RR510 .. i ..

SI

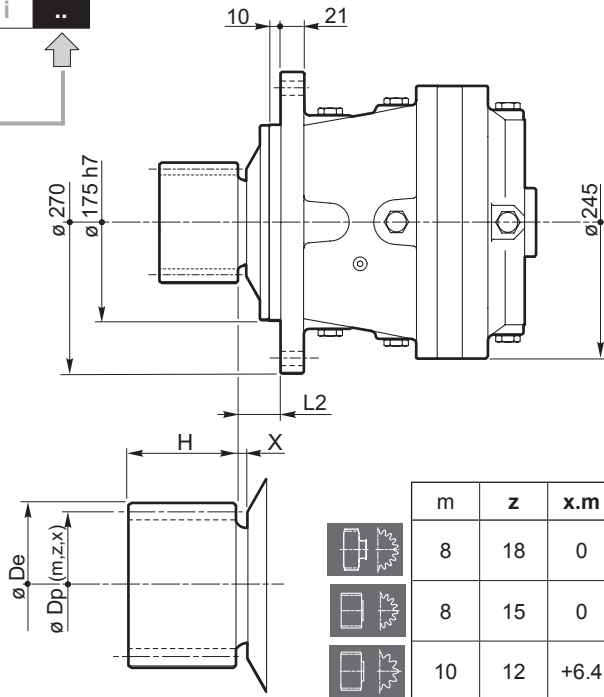

| m | z | x.m | H | Dp | De | L2 | X | code | |
|----|----|------|----|-----|-----|----|------|--------|----------|
| 8 | 18 | 0 | 60 | 144 | 160 | 59 | 28.5 | 03-325 | 154F2898 |
| 8 | 15 | 0 | 80 | 120 | 136 | 36 | 5.5 | 03-500 | 154F2899 |
| 10 | 12 | +6.4 | 80 | 120 | 149 | 40 | 9.5 | 03-579 | 154F5466 |

VI

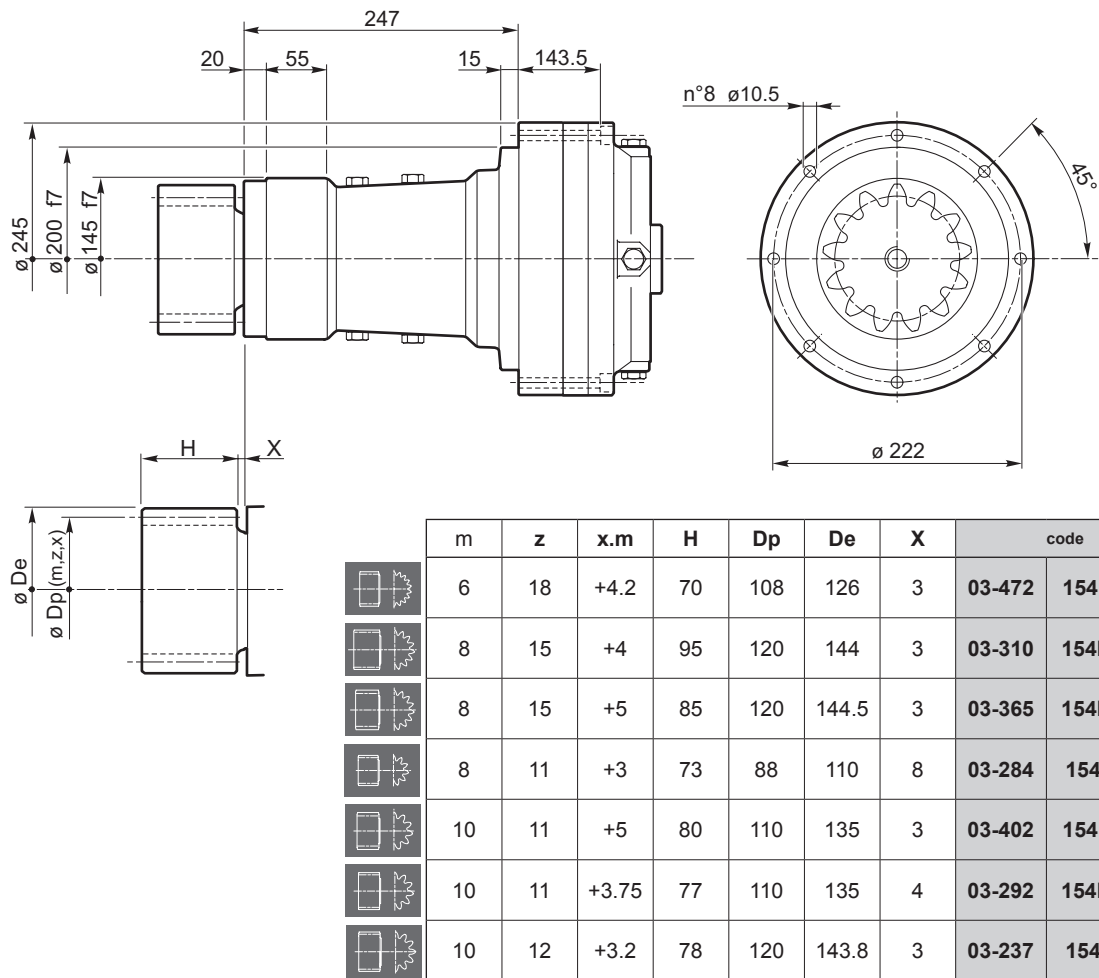

| m | z | x.m | H | Dp | De | X | code | |
|----|----|-------|----|-----|-------|---|--------|----------|
| 6 | 18 | +4.2 | 70 | 108 | 126 | 3 | 03-472 | 154F1663 |
| 8 | 15 | +4 | 95 | 120 | 144 | 3 | 03-310 | 154B2443 |
| 8 | 15 | +5 | 85 | 120 | 144.5 | 3 | 03-365 | 154B4171 |
| 8 | 11 | +3 | 73 | 88 | 110 | 8 | 03-284 | 154-5637 |
| 10 | 11 | +5 | 80 | 110 | 135 | 3 | 03-402 | 154F3597 |
| 10 | 11 | +3.75 | 77 | 110 | 135 | 4 | 03-292 | 154B1799 |
| 10 | 12 | +3.2 | 78 | 120 | 143.8 | 3 | 03-237 | 154-5629 |

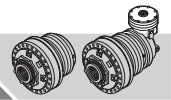

RR510
RA510 .. i **FS**

FS

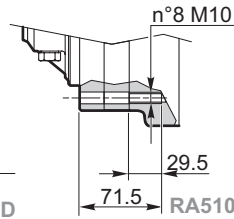
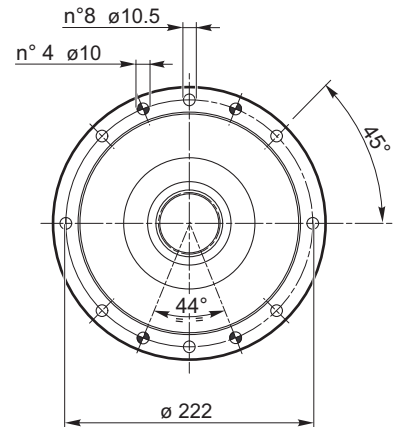
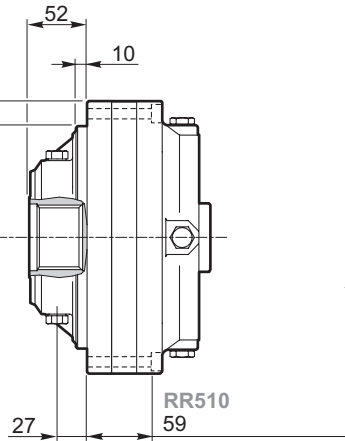

Trattamento termico:
Tempra ad induzione secondo UNI 10932 su scanalato interno

Heat treatment:
Induction hardening according to UNI 10932 on internal spline

Wärmebehandlung:
Induktionshärtung nach UNI 10932 an interner Nut

Traitement thermique:
Trempe par induction conformément à la norme UNI 10932 sur cannelé interne

Tratamiento térmico:
Temple por inducción según UNI 10932 en acanalado interno

Tratamento térmico:
Tempera por indução segundo UNI 10932 sobre ranhuras internas

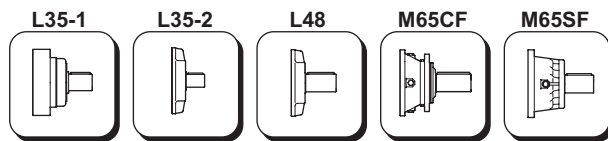
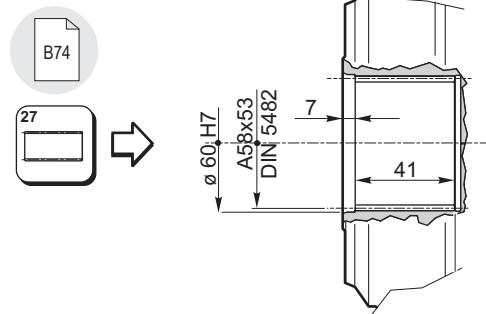
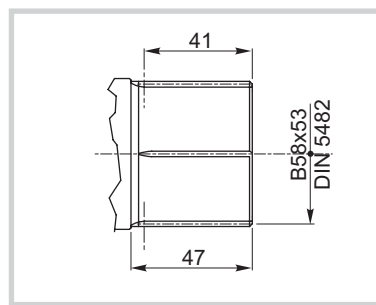

C10

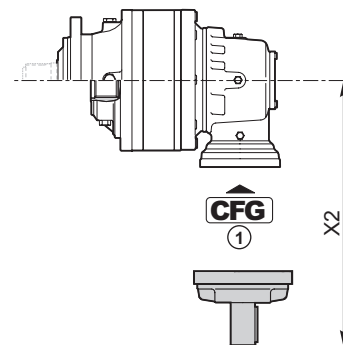
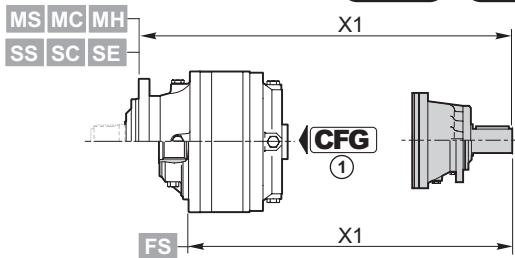

| | CFG ① | | code | X1 |
|---------------|-----------------|--------------|------------|--|
| RR510 | RF | M65SF | 154B4249 | 369.5 (M..) 282.5 (FS) 402.5 (S..) |
| | RF | M65CF | 154-2407 | 392 (M..) 305 (FS) 425 (S..) |
| | BOC | L48 | 154B3989 | 306.5 (M..) 219.5 (FS) 339.5 (S..) |
| RR510D | RF | M65SF | 154B4249 | 436 (M..) 349 (FS) 469 (S..) |
| | RF | M65CF | 154-2407 | 459 (M..) 372 (FS) 492 (S..) |
| | BOC | L48 | 154B3989 | 373 (M..) 286 (FS) 406 (S..) |
| RR510T | BOC | L35-2 | 154-2190M1 | 407 (M..) 320 (FS) 440 (S..) |
| RR510Q | RF | L35-1 | 154B4054 | 423 (M..) 336 (FS) 456 (S..) |

| | CFG ① | | code | X2 |
|---------------|-----------------|--------------|------------|-------|
| RA510 | BOC | L48 | 154B3989 | 347.5 |
| RA510D | BOC | L35-2 | 154-2190M1 | 270.5 |
| RA510T | BOC | L35-2 | 154-2190M1 | 270.5 |

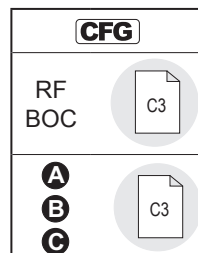

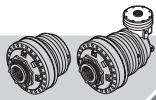

510

IT EN DE FR ES PT

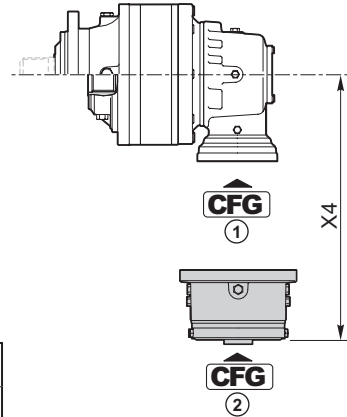
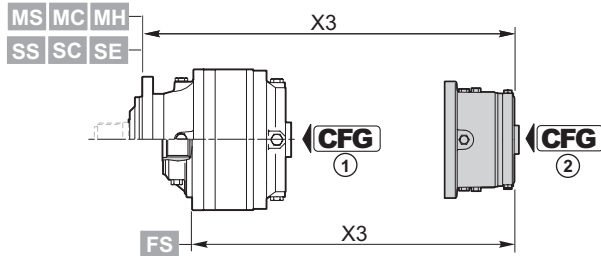
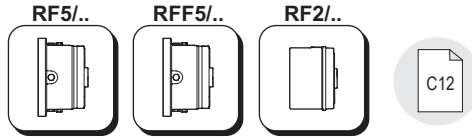

| CFG | |
|-----|----|
| RF | C3 |
| BOC | |
| A | C3 |
| B | |
| C | |

| RF5/.. | CFG ① | T _f [Nm] | CFG ② | | | | | | |
|--------|-------|---------------------|----------|--|----|----------------|----------------|--|----|
| | | | B | | | OMTS 12/24 z16 | OMVS 10/20 z16 | | |
| | | | code | X3 | X4 | code | code | X3 | X4 |
| RR510 | RF | 210 | 154-2872 | 275.5 (M...) 188.5 (FS) 308.5 (S...) | — | 154-2879 | 154-2886 | 279.2 (M...) 192.2 (FS) 312.2 (S...) | — |
| | | 290 | 154-2873 | | | 154-2880 | 154-2887 | | |
| | | 430 | 154-2874 | | | 154-2881 | 154-2888 | | |
| | | 650 | 154-2875 | | | 154-2882 | 154-2889 | | |
| | | 850 | 154-2876 | | | 154-2883 | 154-2890 | | |
| | | 1100 | 154-2877 | | | 154-2884 | 154-2891 | | |
| RR510D | RF | 210 | 154-2872 | 342 (M...) 255 (FS) 375 (S...) | — | 154-2879 | 154-2886 | 345.7 (M...) 258.7 (FS) 378.7 (S...) | — |
| | | 290 | 154-2873 | | | 154-2880 | 154-2887 | | |
| | | 430 | 154-2874 | | | 154-2881 | 154-2888 | | |
| | | 650 | 154-2875 | | | 154-2882 | 154-2889 | | |
| | | 850 | 154-2876 | | | 154-2883 | 154-2890 | | |
| | | 1100 | 154-2877 | | | 154-2884 | 154-2891 | | |
| | | 1300 | 154-2878 | | | 154-2885 | 154-2892 | | |

| RFF5/.. | CFG ① | T _f [Nm] | CFG ② | | | | | | | | | | | | |
|---------|-------|---------------------|----------|----|-------|----------------|----------------|----|-------|--|--|----------|----------|--|--|
| | | | B | | | OMTS 12/24 z16 | OMVS 10/20 z16 | | | | | | | | |
| | | | code | X3 | X4 | code | code | X3 | X4 | | | | | | |
| RA510 | RF | 210 | 154-2893 | — | 316.6 | 154-5338 | 154-5345 | — | 320.5 | | | | | | |
| | | 290 | 154-2894 | | | 154-5339 | 154-5346 | | | | | | | | |
| | | 430 | 154-2895 | | | 154-5340 | 154-5347 | | | | | | | | |
| | | 650 | 154-2896 | | | 154-5341 | 154-5348 | | | | | | | | |
| | | 850 | 154-2897 | | | 154-5342 | 154-5349 | | | | | | | | |
| | | 1100 | 154-2898 | | | 154-5343 | 154-5350 | | | | | | | | |
| | | | | | | 1300 | 154-2899 | | | | | 154-5344 | 154-5351 | | |



| RF2/.. | CFG ① | T _f [Nm] | CFG ② | | | | | | |
|--------|----------|------------------------|------------|--|-----------------------------|------------------------------|-----------------------------|------------------------------|--|
| | | | B | | OMP/OMR SAE A 2B Ø 25 | OMP/OMR SAE A 2B 1" 6B | OMP/OMR SAE A 4B Ø 25 | OMP/OMR SAE A 4B 1" 6B | X3 |
| | | | code | X3 | code | code | code | code | |
| RR510 | RF | 70 | 154B9195 | 248 (M...) 161 (FS) 281 (S...) | 154B9195M10 | — | 154B9195M16 | 154B9195M17 | 238 (M...) 151 (FS) 271 (S...) |
| | | 140 | 154B9196 | | 154B9196M10 | — | 154B9196M16 | 154B9196M17 | |
| | | 210 | 154B9197 | | 154B9197M10 | — | 154B9197M16 | 154B9197M17 | |
| | | 320 | 154B9198 | | 154B9198M10 | — | 154B9198M16 | 154B9198M17 | |
| | | 430 | 154B9199 | | 154B9199M10 | — | 154B9199M16 | 154B9199M17 | |
| | | 600 | 154B9200 | | 154B9200M10 | — | 154B9200M16 | 154B9200M17 | |
| RR510D | RF | 70 | 154-2345 | 314.5 (M...) 227.5 (FS) 347.5 (S...) | 154-2345M10 | 154-2345M11 | 154-2345M16 | 154-2345M17 | 304.5 (M...) 217.5 (FS) 337.5 (S...) |
| | | 140 | 154-2346 | | 154-2346M10 | 154-2346M11 | 154-2346M16 | 154-2346M17 | |
| | | 210 | 154-2347 | | 154-2347M10 | 154-2347M11 | 154-2347M16 | 154-2347M17 | |
| | | 320 | 154-2348 | | 154-2348M10 | 154-2348M11 | 154-2348M16 | 154-2348M17 | |
| | | 430 | 154-2349 | | 154-2349M10 | 154-2349M11 | 154-2349M16 | 154-2349M17 | |
| | | 600 | 154B9186 | | 154B9186M10 | 154B9186M11 | 154B9186M16 | 154B9186M17 | |
| RR510T | RF | 70 | 154-2838M1 | 356 (M...) 269 (FS) 389 (S...) | 154-2863 | 154-2863M11 | 154-2635 | 154-2635M11 | 346 (M...) 259 (FS) 379 (S...) |
| | | 140 | 154-2839M1 | | 154-2864 | 154-2864M11 | 154-2636 | 154-2636M11 | |
| | | 210 | 154-2840M1 | | 154-2865 | 154-2865M11 | 154-2637 | 154-2637M11 | |
| | | 320 | 154-2841M1 | | 154-2866 | 154-2866M11 | 154-2638 | 154-2638M11 | |
| | | 430 | 154-2842M1 | | 154-2867 | 154-2867M11 | 154-2639 | 154-2639M11 | |
| | | 600 | 154B8962M1 | | 154B9665 | 154B9665M11 | 154B9666 | 154B9666M11 | |

| | CFG ① | T _f [Nm] | CFG ② | | | | | | |
|--------|----------|------------------------|------------|--------------------------------------|-----------------------------|------------------------------|-----------------------------|------------------------------|--|
| | | | A | | OMP/OMR SAE A 2B Ø 25 | OMP/OMR SAE A 2B 1" 6B | OMP/OMR SAE A 4B Ø 25 | OMP/OMR SAE A 4B 1" 6B | X3 |
| | | | code | X3 | code | code | code | code | |
| RR510Q | RF | 70 | 154-2832M1 | 401 (M...) 314 (FS) 434 (S...) | 154-2858M1 | 154-2858M5 | | | 396.5 (M...) 309.5 (FS) 429.5 (S...) |
| | | 140 | 154-2833M1 | | 154-2859M1 | 154-2859M5 | | | |
| | | 210 | 154-2834M1 | | 154-2860M1 | 154-2860M5 | | | |
| | | 320 | 154-2836M1 | | 154-2861M1 | 154-2861M5 | | | |
| | | 430 | 154-2837M1 | | 154-2862M1 | 154-2862M5 | | | |
| | | 600 | 154B8959M1 | | 154B9663M1 | 154B9663M5 | | | |

| | CFG ① | T _f [Nm] | CFG ② | | | | | | |
|--------|----------|------------------------|-------------|-------|-----------------------------|------------------------------|-----------------------------|------------------------------|-------|
| | | | B | | OMP/OMR SAE A 2B Ø 25 | OMP/OMR SAE A 2B 1" 6B | OMP/OMR SAE A 4B Ø 25 | OMP/OMR SAE A 4B 1" 6B | X4 |
| | | | code | X4 | code | code | code | code | |
| RA510 | RF | 70 | 154F2991 | 285.3 | | | | | |
| | | 140 | 154F1890 | | | | | | |
| | | 210 | 154F2961 | | | | | | |
| | | 320 | 154B3591 | | | | | | |
| | | 430 | 154B3592 | | | | | | |
| | | 600 | 154F2992 | | | | | | |
| RA510D | RF | 70 | 154-2838M12 | 223.8 | 154-2863M12 | 154-2863M13 | 154-2635M12 | | 213.8 |
| | | 140 | 154-2839M12 | | 154-2864M12 | 154-2864M13 | 154-2636M12 | | |
| | | 210 | 154-2840M12 | | 154-2865M12 | 154-2865M13 | 154-2637M12 | | |
| | | 320 | 154-2841M12 | | 154-2866M12 | 154-2866M13 | 154-2638M12 | | |
| | | 430 | 154-2842M12 | | 154-2867M12 | 154-2867M13 | 154-2639M12 | | |
| | | 600 | 154B8962M12 | | 154B9665M12 | 154B9665M13 | 154B9666M12 | | |
| RA510T | RF | 70 | 154-2838M12 | 223.8 | 154-2863M12 | 154-2863M13 | 154-2635M12 | | 213.8 |
| | | 140 | 154-2839M12 | | 154-2864M12 | 154-2864M13 | 154-2636M12 | | |
| | | 210 | 154-2840M12 | | 154-2865M12 | 154-2865M13 | 154-2637M12 | | |
| | | 320 | 154-2841M12 | | 154-2866M12 | 154-2866M13 | 154-2638M12 | | |
| | | 430 | 154-2842M12 | | 154-2867M12 | 154-2867M13 | 154-2639M12 | | |
| | | 600 | 154B8962M12 | | 154B9665M12 | 154B9665M13 | 154B9666M12 | | |

| | |
|-----|--|
| CFG | |
| RF | |
| BOC | |
| A | |
| B | |
| C | |

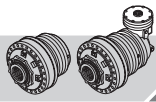

12
Kg 0.2

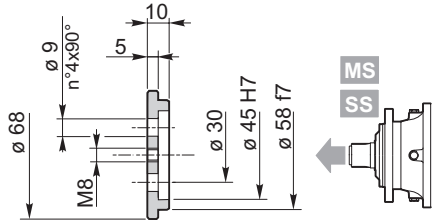

154-3061

Materiale / Material / Material / Matériau / Material / Material:
Acciaio / Steel / Stahl / Acier / Acero / Aço
C40 EN 10083-1 (1.1186)

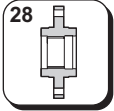

28

Materiale / Material / Material / Matériau / Material / Material: **Acciaio / Steel / Stahl / Acier / Acero / Aço EN 10083-1-C40 (1.1186)**

Trattamento termico:
 Tempra ad induzione secondo UNI 10932 su scanalato interno
Heat treatment:
 Induction hardening according to UNI 10932 on internal spline
Wärmebehandlung:
 Induktionshärtung nach UNI 10932 an interner Nut

Traitement thermique :
 Trempe par induction conformément à la norme UNI 10932 sur cannelé interne
Tratamiento térmico:
 Temple por inducción según UNI 10932 en acanalado interno
Tratamento térmico:
 Tempera por indução segundo UNI 10932 sobre ranhuras internas

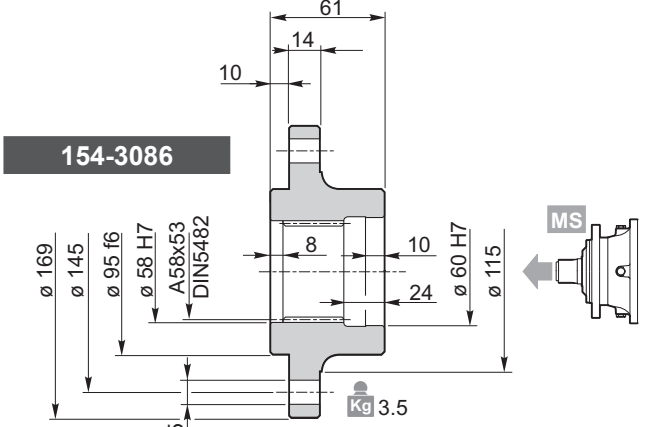

154-3086

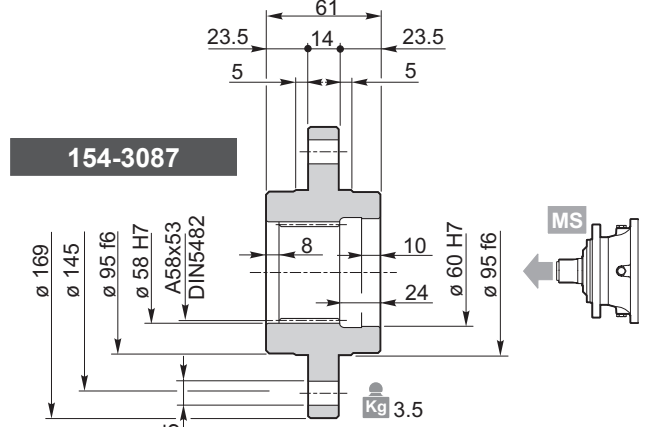

154-3087

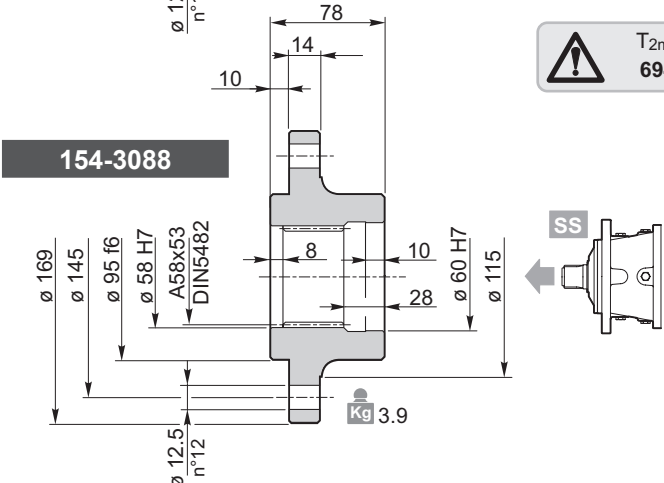

154-3088

T_{2max} = 6940 Nm

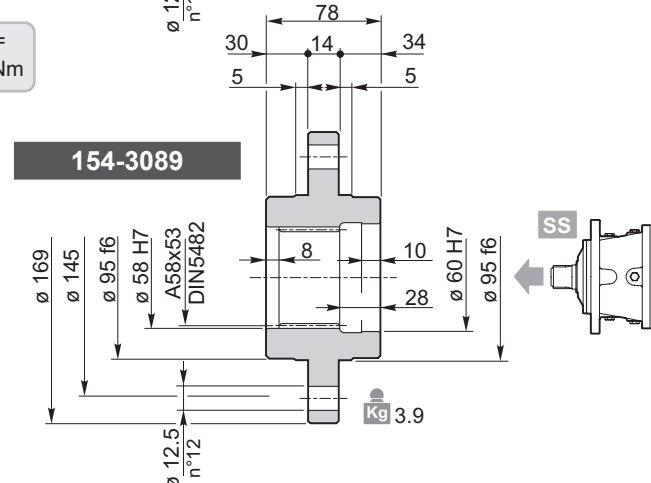

154-3089



29

Materiale / Material / Material / Matériau / Material / Material: **Acciaio / Steel / Stahl / Acier / Acero / Aço 39NiCrMo3 UNI 7845 (1.6511)**

Trattamento termico:
 Tempra ad induzione secondo UNI 10932 su scanalato interno
Heat treatment:
 Induction hardening according to UNI 10932 on internal spline
Wärmebehandlung:
 Induktionshärtung nach UNI 10932 an interner Nut

Traitement thermique :
 Trempe par induction conformément à la norme UNI 10932 sur cannelé interne
Tratamiento térmico:
 Temple por inducción según UNI 10932 en acanalado interno
Tratamento térmico:
 Tempera por indução segundo UNI 10932 sobre ranhuras internas

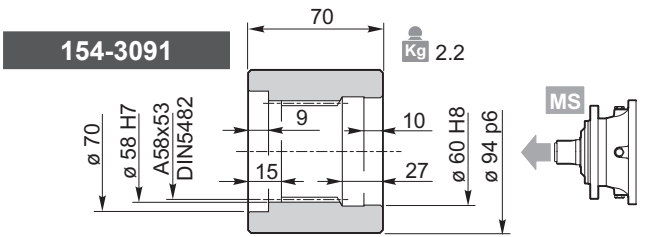

154-3091

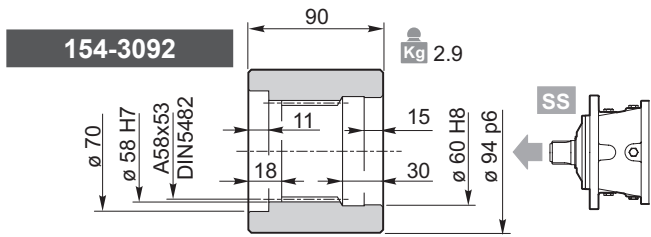

154-3092

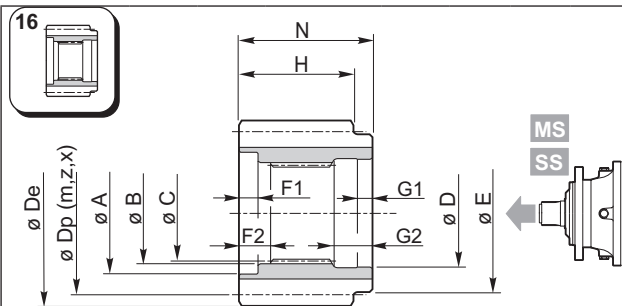
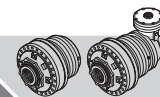

Materiale / Material / Material
Matériau / Material / Material
Acciaio / Steel / Stahl / Acier / Acero / Aço
39NiCrMo3 UNI 7845 (1.6511)

Trattamento termico:
 Tempra ad induzione secondo UNI 10932 su scanalato interno

Heat treatment:
 Induction hardening according to UNI 10932 on internal spline

Wärmebehandlung:
 Induktionshärtung nach UNI 10932 an interner Nut

Traitement thermique:
 Tempe par induction conformément à la norme UNI 10932 sur cannelé interne

Tratamiento térmico:
 Temple por inducción según UNI 10932 en acanalado interno

Tratamento térmico:
 Tempera por indução segundo UNI 10932 sobre ranhuras internas

| | A | B | C | D | E | F1 | F2 | G1 | G2 | N | m | z | x | H | Dp | De | Code |
|----|-------|-------------------|-------------------|-------|----|----|----|----|----|----|-----|----|--------|-----|-----|----------|----------|
| MS | 70 | 58 H7 | DIN5482 A58x53 | 60 H7 | 72 | 7 | 13 | 12 | 27 | 68 | 4.5 | 18 | 0.4444 | 65 | 81 | 93 | 154-3106 |
| | 70 | 58 H7 | DIN5482 A58x53 | 60 H7 | 68 | 7 | 13 | 10 | 27 | 68 | 5 | 17 | 0.4 | 65 | 85 | 98 | 154-2287 |
| | 70 | 58 H7 | DIN5482 A58x53 | 60 H7 | 68 | 7 | 13 | 10 | 27 | 68 | 5 | 19 | 0 | 65 | 95 | 104 | 154-2286 |
| | 70 | 58 H7 | DIN5482 A58x53 | 60 H7 | 75 | 7 | 13 | 12 | 27 | 68 | 6 | 14 | 0.5 | 65 | 84 | 101.5 | 154-3082 |
| | 70 | 58 H7 | DIN5482 A58x53 | 60 H7 | 68 | 7 | 13 | 10 | 27 | 68 | 6 | 15 | 0.25 | 65 | 90 | 103 | 154-3107 |
| | 70 | 58 H7 | DIN5482 A58x53 | 60 H7 | 68 | 7 | 13 | 10 | 27 | 68 | 6 | 16 | 0.25 | 65 | 96 | 109 | 154-3245 |
| | 70 | 58 H7 | DIN5482 A58x53 | 60 H7 | 78 | 7 | 13 | 12 | 27 | 68 | 8 | 12 | 0.5 | 65 | 96 | 118 | 154-3074 |
| | 70 | 58 H7 | DIN5482 A58x53 | 60 H7 | 68 | 7 | 13 | 10 | 27 | 68 | 8 | 14 | 0 | 65 | 112 | 126 | 154-3250 |
| | 70 | 58 H7 | DIN5482 A58x53 | 60 H7 | 78 | 7 | 13 | 12 | 27 | 68 | 8 | 15 | 0 | 65 | 120 | 136 | 154-3246 |
| | 70 | 58 H7 | DIN5482 A58x53 | 60 H7 | 68 | 7 | 13 | 10 | 27 | 68 | 8 | 15 | 0.25 | 65 | 120 | 138 | 154-3235 |
| | 70 | 58 H7 | DIN5482 A58x53 | 60 H7 | 78 | 7 | 13 | 12 | 27 | 68 | 8 | 18 | 0 | 65 | 144 | 158 | 154-3103 |
| | 70 | 58 H7 | DIN5482 A58x53 | 60 H7 | 78 | 7 | 13 | 12 | 27 | 68 | 10 | 10 | 0.25 | 65 | 100 | 124.5 | 154-3075 |
| | 70 | 58 H7 | DIN5482 A58x53 | 60 H7 | 78 | 7 | 13 | 12 | 27 | 68 | 10 | 12 | 0.475 | 65 | 120 | 149.5 | 154-3105 |
| | 70 | 58 H7 | DIN5482 A58x53 | 60 H7 | 68 | 7 | 13 | 10 | 27 | 68 | 10 | 15 | 0 | 65 | 150 | 167 | 154-3248 |
| SS | 70 | 58 H7 | DIN5482 A58x53 | 60 H7 | 78 | 5 | 12 | 12 | 30 | 84 | 6 | 14 | 0.5 | 80 | 84 | 101.5 | 154-3238 |
| | 70 | 58 H7 | DIN5482 A58x53 | 60 H7 | 78 | 5 | 12 | 12 | 30 | 84 | 6 | 16 | 0.4167 | 80 | 96 | 111 | 154-3234 |
| | 70 | 58 H7 | DIN5482 A58x53 | 60 H7 | 78 | 5 | 12 | 12 | 30 | 84 | 6 | 19 | 0 | 80 | 114 | 126 | 154-2706 |
| | 70 | 58 H7 | DIN5482 A58x53 | 60 H7 | 78 | 6 | 12 | 10 | 30 | 84 | 6 | 24 | 0 | 80 | 144 | 154 | 154-3101 |
| | 70 | 58 H7 | DIN5482 A58x53 | 60 H7 | 78 | 5 | 12 | 12 | 30 | 84 | 7 | 13 | 0.5 | 80 | 91 | 109 | 154-3038 |
| | 70 | 58 H7 | DIN5482 A58x53 | 60 H7 | 78 | 5 | 12 | 12 | 30 | 84 | 8 | 12 | 0.5 | 80 | 96 | 118 | 154-3076 |
| | 70 | 58 H7 | DIN5482 A58x53 | 60 H7 | 78 | 5 | 12 | 12 | 30 | 84 | 8 | 13 | 0.35 | 80 | 104 | 125.6 | 154-3236 |
| | 70 | 58 H7 | DIN5482 A58x53 | 60 H7 | 78 | 5 | 12 | 12 | 30 | 84 | 8 | 15 | 0.25 | 80 | 120 | 138 | 154-2288 |
| | 70 | 58 H7 | DIN5482 A58x53 | 60 H7 | 78 | 5 | 12 | 12 | 30 | 84 | 8 | 18 | 0 | 80 | 144 | 158 | 154-2716 |
| | 70 | 58 H7 | DIN5482 A58x53 | 60 H7 | 78 | 5 | 12 | 12 | 30 | 84 | 10 | 10 | 0.25 | 80 | 100 | 124.5 | 154-3067 |
| | 70 | 58 H7 | DIN5482 A58x53 | 60 H7 | 78 | 5 | 12 | 12 | 30 | 84 | 10 | 12 | 0.475 | 80 | 120 | 149.5 | 154-3077 |
| | 70 | 58 H7 | DIN5482 A58x53 | 60 H7 | 78 | 5 | 12 | 12 | 30 | 84 | 10 | 13 | 0 | 80 | 130 | 148 | 154-3070 |
| | 70 | 58 H7 | DIN5482 A58x53 | 60 H7 | 78 | 5 | 12 | 12 | 30 | 84 | 10 | 14 | 0.4 | 80 | 140 | 164 | 154-2289 |
| | 70 | 58 H7 | DIN5482 A58x53 | 60 H7 | 78 | 5 | 12 | 12 | 30 | 84 | 10 | 15 | 0 | 80 | 150 | 169 | 154-3078 |
| 70 | 58 H7 | DIN5482 A58x53 | 60 H7 | 78 | 5 | 12 | 12 | 30 | 84 | 10 | 16 | 0 | 80 | 160 | 178 | 154-3108 | |

154-3052

Materiale / Materiale / Material
Matériau / Material / Material:
Acciaio / Steel / Stahl / Acier / Acero / Aço
39NiCrMo3 UNI 7845 (1.6511)

154B3090

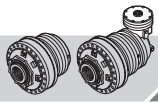

510

IT EN DE FR ES PT

| | | | |
|----|-----|----|-----------|
| RR | 510 | .. | MS |
| RA | | | MC |

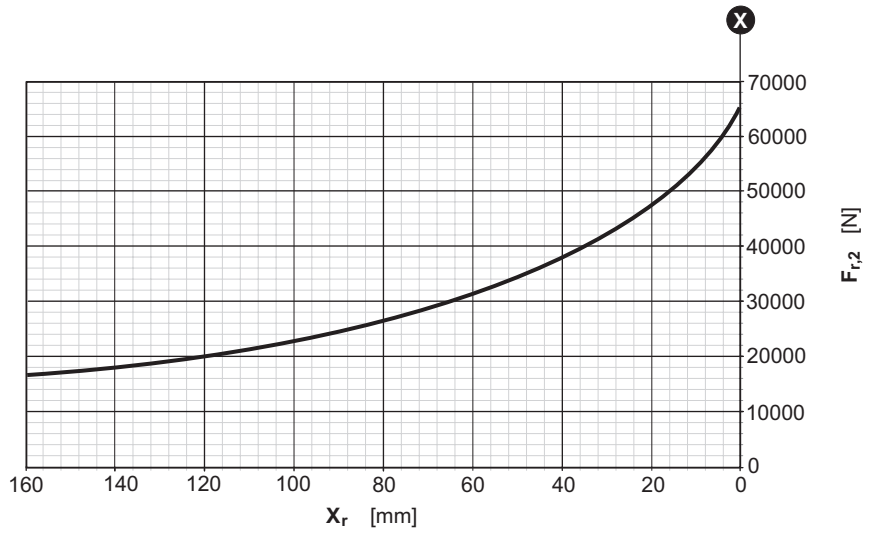
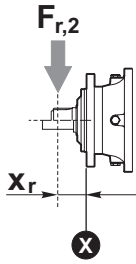

| | | | |
|----|-----|----|-----------|
| RR | 510 | .. | SS |
| RA | | | SC |
| | | | SE |

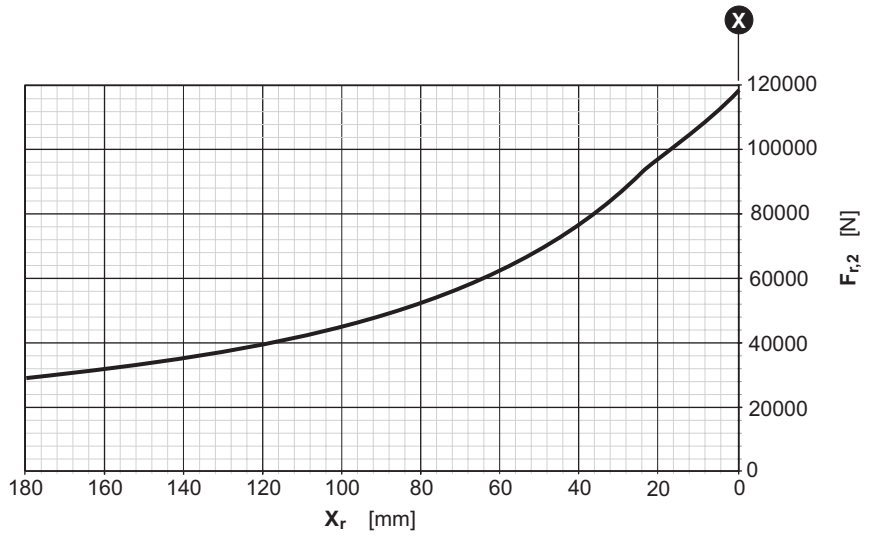
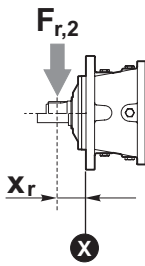

| | | | |
|----|-----|----|-----------|
| RR | 510 | .. | UC |
| RA | | | |

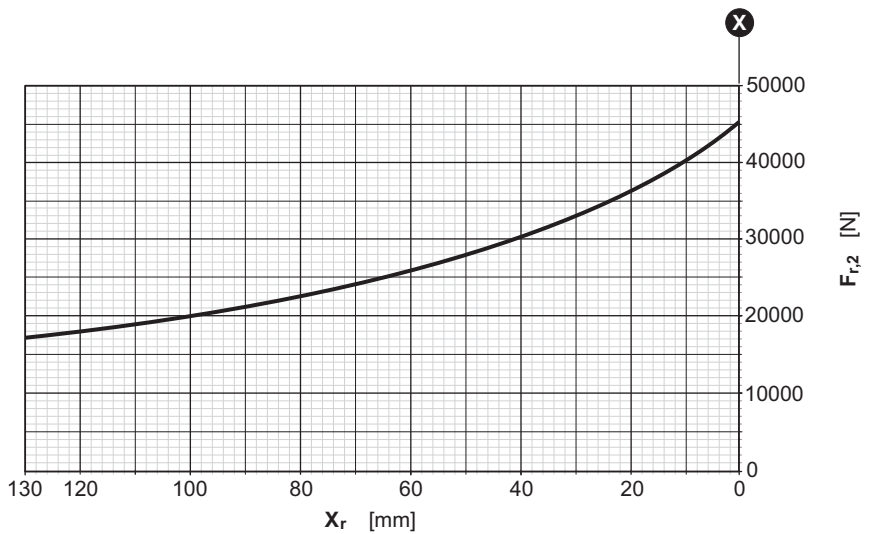
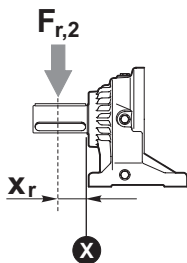



RR 510 .. SI

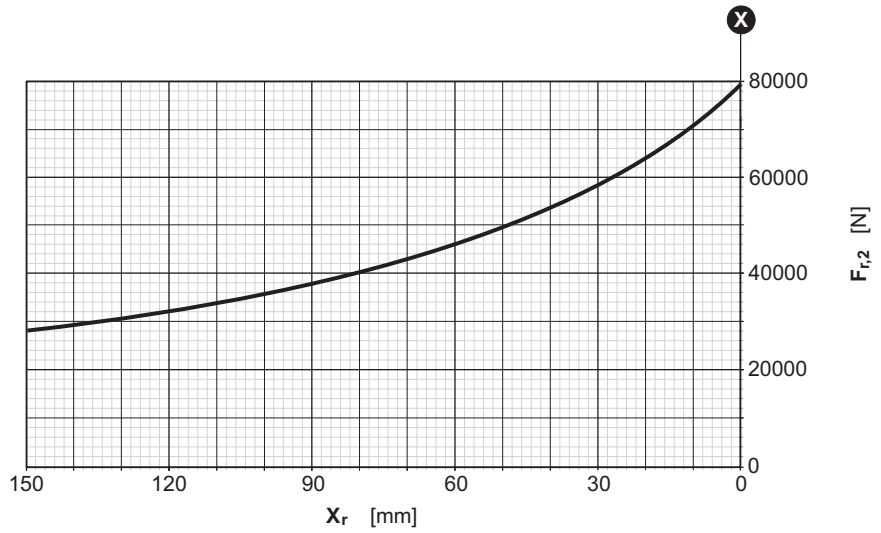
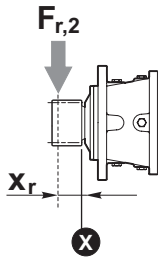

RR 510 .. VI

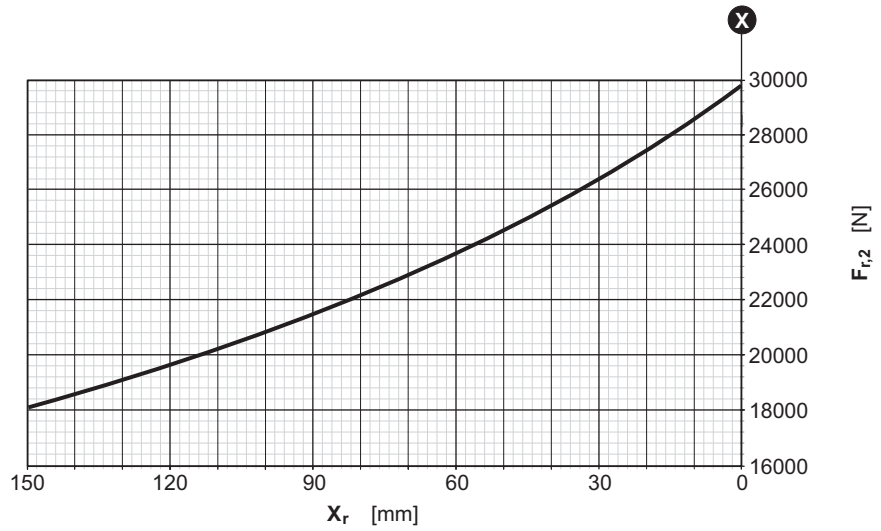
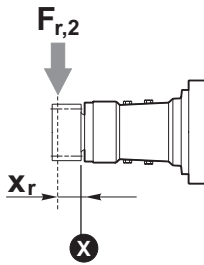

Fattore correttivo k_{r2} / k_{r2} Corrective coefficient / Korrekturfaktor k_{r2}
 Facteur correctif k_{r2} / Factor de corrección k_{r2} / Fator corretivo k_{r2}

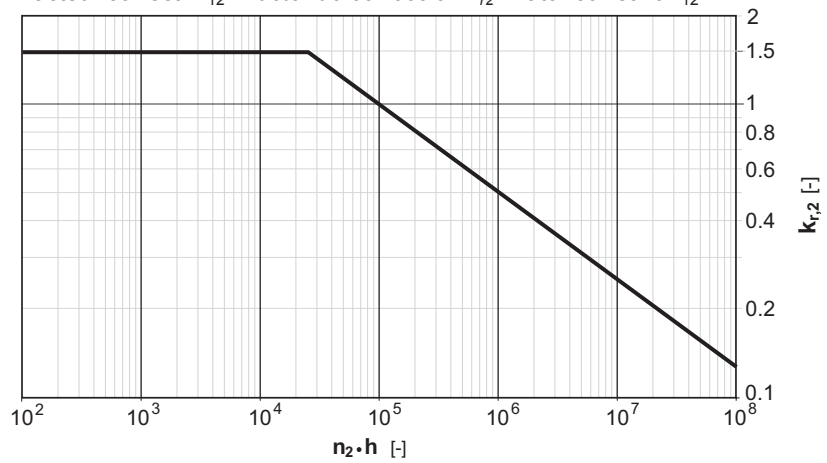



710

IT EN DE FR ES PT

RR710

..

i



| | i | T ₂ [Nm] | | | | | | n _{1max} [min ⁻¹] | T _{2max} [Nm] | P _t [kW] |
|---------------|----------------|-----------------------------|-----------------------------------|---------------------------------|------------------------------|----------------------------------|-------------------------------|---|-------------------------------------|------------------------|
| | | n ₂ x h | | | | | | | | |
| 1/... | | 10000 (10 ⁴) | 25000 (2.5 · 10 ⁴) | 50000 (5 · 10 ⁴) | 100000 (10 ⁵) | 500000 (5 · 10 ⁵) | 1000000 (10 ⁶) | | | |
| RR710 | 4.00 | 7320 | 6170 | 5420 | 4810 | 4360 | 3980 | 3500 | 8500 (M.../FS) 9300 (S...) | 21 |
| | 5.20 | 5070 | 4260 | 3740 | 3460 | 3130 | 3000 | | | |
| | 6.25 | 4400 | 3710 | 3260 | 3100 | 2810 | 2690 | | | |
| RR710D | 16.00 | 7320 | 6170 | 5420 | 4810 | 4360 | 3980 | 3500 | 8500 (M.../FS) 9300 (S...) | 13 |
| | 23.20 | 7320 | 6170 | 5420 | 4810 | 4360 | 3980 | | | |
| | 28.00 | 6050 | 5610 | 5380 | 4810 | 4360 | 3980 | | | |
| | 36.25 | 4400 | 3710 | 3260 | 3100 | 2810 | 2690 | | | |
| | 43.75 | 4400 | 3710 | 3260 | 3100 | 2810 | 2690 | | | |
| RR710T | 51.36 | 7320 | 6170 | 5420 | 4810 | 4360 | 3980 | 3500 | 8500 (M.../FS) 9300 (S...) | 10 |
| | 65.60 | 7320 | 6170 | 5420 | 4810 | 4360 | 3980 | | | |
| | 74.47 | 7320 | 6170 | 5420 | 4810 | 4360 | 3980 | | | |
| | 95.12 | 7320 | 6170 | 5420 | 4810 | 4360 | 3980 | | | |
| | 115.2 | 7320 | 6170 | 5420 | 4810 | 4360 | 3980 | | | |
| | 151.76 | 6050 | 5610 | 5380 | 4810 | 4360 | 3980 | | | |
| | 201.6 | 6050 | 5610 | 5380 | 4810 | 4360 | 3980 | | | |
| | 261.00 | 4400 | 3710 | 3260 | 3100 | 2810 | 2690 | | | |
| | 315.00 | 4400 | 3710 | 3260 | 3100 | 2810 | 2690 | | | |
| RR710Q | 346.29 | 7320 | 6170 | 5420 | 4810 | 4360 | 3980 | 3500 | 8500 (M.../FS) 9300 (S...) | 8 |
| | 407.38 | 7320 | 6170 | 5420 | 4810 | 4360 | 3980 | | | |
| | 442.31 | 7320 | 6170 | 5420 | 4810 | 4360 | 3980 | | | |
| | 535.68 | 7320 | 6170 | 5420 | 4810 | 4360 | 3980 | | | |
| | 590.70 | 7320 | 6170 | 5420 | 4810 | 4360 | 3980 | | | |
| | 715.39 | 7320 | 6170 | 5420 | 4810 | 4360 | 3980 | | | |
| | 937.44 | 6050 | 5610 | 5380 | 4810 | 4360 | 3980 | | | |
| | 1251.94 | 6050 | 5610 | 5380 | 4810 | 4360 | 3980 | | | |
| | 1464.75 | 4400 | 3710 | 3260 | 3100 | 2810 | 2690 | | | |
| | 1620.81 | 4400 | 3710 | 3260 | 3100 | 2810 | 2690 | | | |
| | 1956.15 | 4400 | 3710 | 3260 | 3100 | 2810 | 2690 | | | |



RA710 .. **i**



| i | T ₂ [Nm] | | | | | | n _{1max} [min ⁻¹] | T _{2max} [Nm] | P _t [kW] | |
|---------------|-----------------------------|-----------------------------------|---------------------------------|------------------------------|----------------------------------|-------------------------------|---|---------------------------|-------------------------------------|----|
| | n ₂ x h | | | | | | | | | |
| 1/... | 10000 (10 ⁴) | 25000 (2.5 · 10 ⁴) | 50000 (5 · 10 ⁴) | 100000 (10 ⁵) | 500000 (5 · 10 ⁵) | 1000000 (10 ⁶) | | | | |
| RA710 | 16.00 | 6680 | 6050 | 5340 | 4810 | 3870 | 3140 | 3500 | 8500 (M.../FS) 9300 (S...) | 23 |
| | 20.80 | 5070 | 4260 | 3740 | 3460 | 3130 | 3000 | | | |
| | 25.00 | 4400 | 3710 | 3260 | 3100 | 2810 | 2690 | | | |
| RA710D | 51.52 | 6910 | 6110 | 5420 | 4810 | 3640 | 2960 | 3500 | 8500 (M.../FS) 9300 (S...) | 14 |
| | 74.70 | 7320 | 6170 | 5420 | 4810 | 4360 | 3840 | | | |
| | 90.16 | 6050 | 5610 | 5380 | 4810 | 4360 | 3980 | | | |
| | 116.73 | 4400 | 3710 | 3260 | 3100 | 2810 | 2690 | | | |
| | 140.88 | 4400 | 3710 | 3260 | 3100 | 2810 | 2690 | | | |
| | 164.86 | 4210 | 3900 | 3690 | 3490 | 3060 | 2890 | | | |
| | 177.58 | 4500 | 4180 | 3740 | 3460 | 3130 | 3000 | | | |
| | 184.00 | 4400 | 3710 | 3260 | 3100 | 2810 | 2690 | | | |
| | 214.32 | 5070 | 4260 | 3740 | 3460 | 3130 | 3000 | | | |
| | 257.60 | 4400 | 3710 | 3260 | 3100 | 2810 | 2690 | | | |
| RA710T | 165.38 | 7320 | 6170 | 5420 | 4810 | 4360 | 3980 | 3500 | 8500 (M.../FS) 9300 (S...) | 11 |
| | 211.23 | 7320 | 6170 | 5420 | 4810 | 4360 | 3980 | | | |
| | 239.80 | 7320 | 6170 | 5420 | 4810 | 4360 | 3980 | | | |
| | 306.29 | 7320 | 6170 | 5420 | 4810 | 4360 | 3980 | | | |
| | 370.94 | 7320 | 6170 | 5420 | 4810 | 4360 | 3980 | | | |
| | 488.67 | 6050 | 5610 | 5380 | 4810 | 4360 | 3980 | | | |
| | 649.15 | 6050 | 5610 | 5380 | 4810 | 4360 | 3980 | | | |
| | 840.42 | 4400 | 3710 | 3260 | 3100 | 2810 | 2690 | | | |
| | 1014.30 | 4400 | 3710 | 3260 | 3100 | 2810 | 2690 | | | |
| | 1187.02 | 6050 | 5610 | 5380 | 4810 | 4360 | 3980 | | | |
| | 1278.59 | 5070 | 4260 | 3740 | 3460 | 3130 | 3000 | | | |
| | 1396.19 | 4400 | 3710 | 3260 | 3100 | 2810 | 2690 | | | |
| | 1543.13 | 5070 | 4260 | 3740 | 3460 | 3130 | 3000 | | | |
| | 1854.72 | 4400 | 3710 | 3260 | 3100 | 2810 | 2690 | | | |



710

IT EN DE FR ES PT

RR710 .. i ..

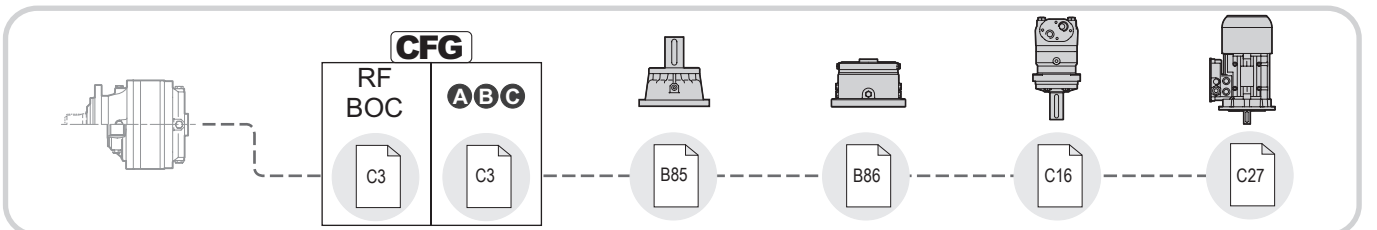
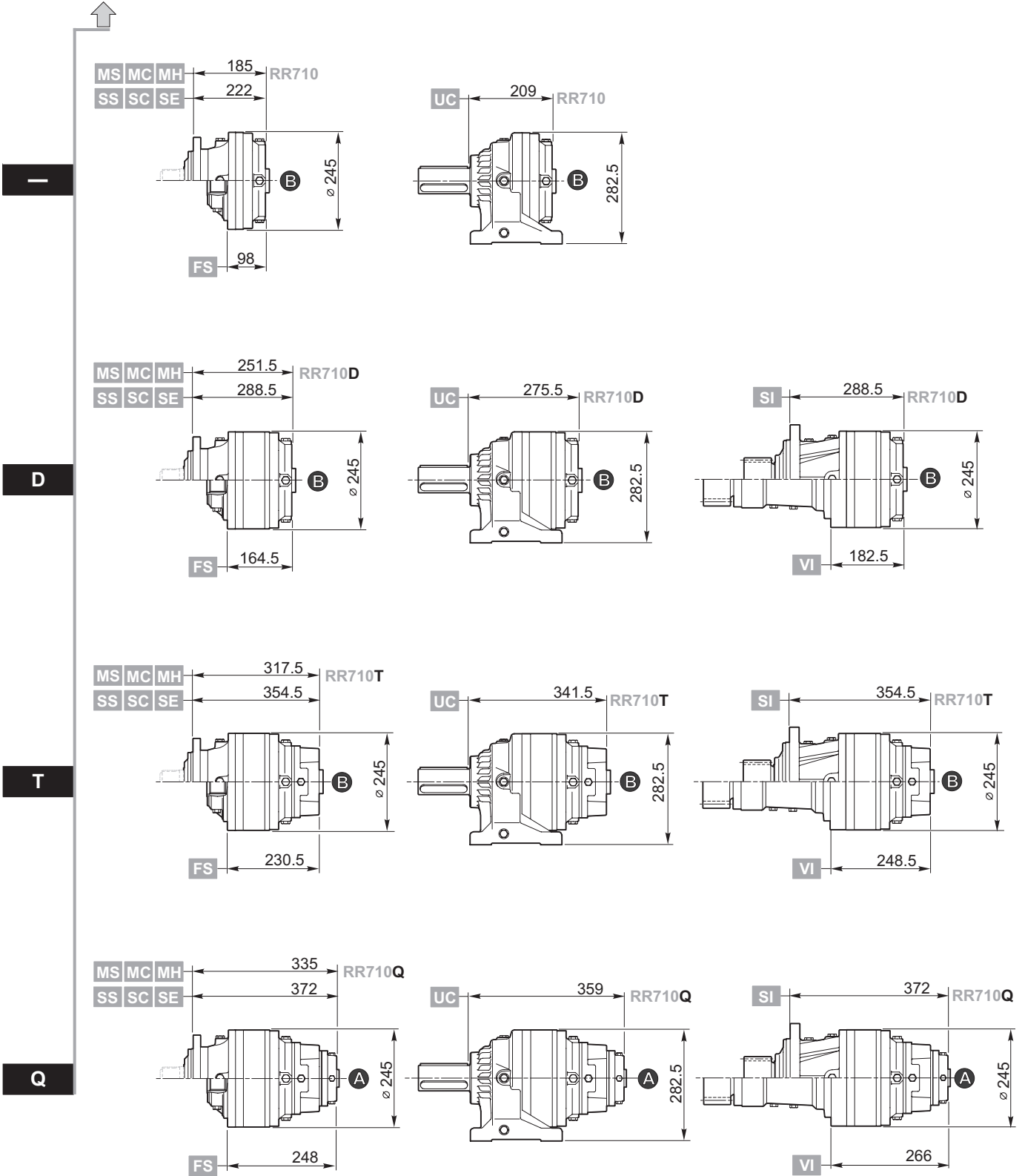

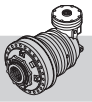

RA710 .. i ..

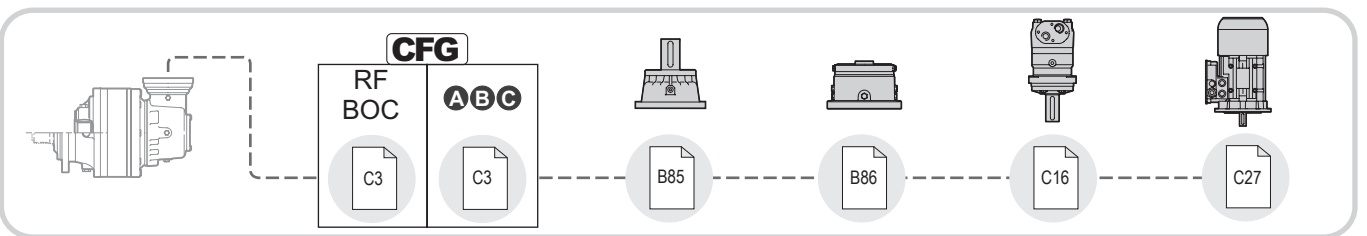
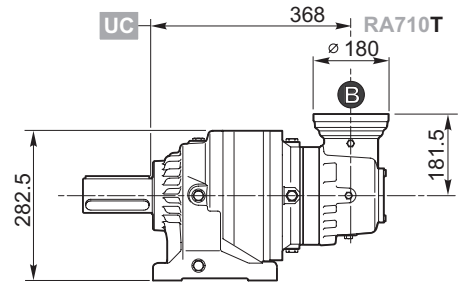
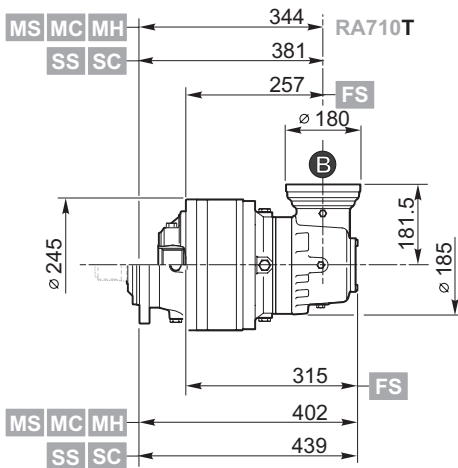
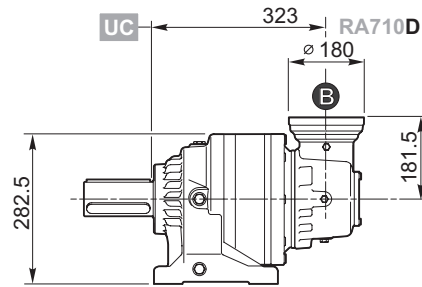
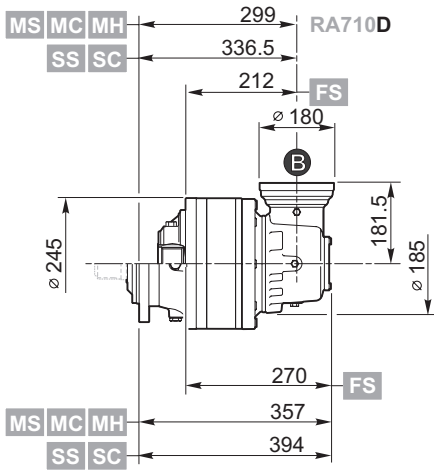
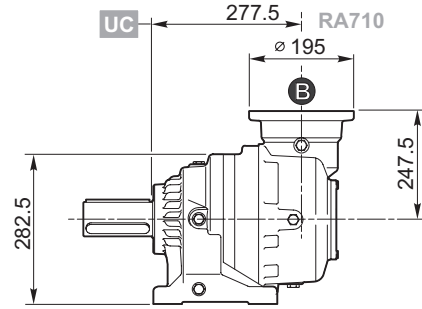
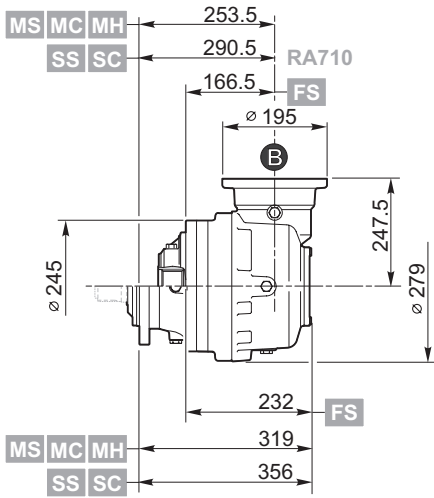

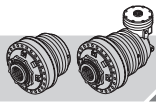







710

IT EN DEFRES PT

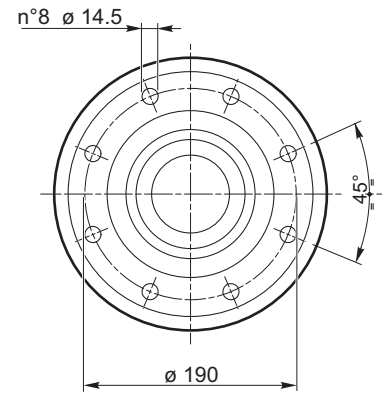
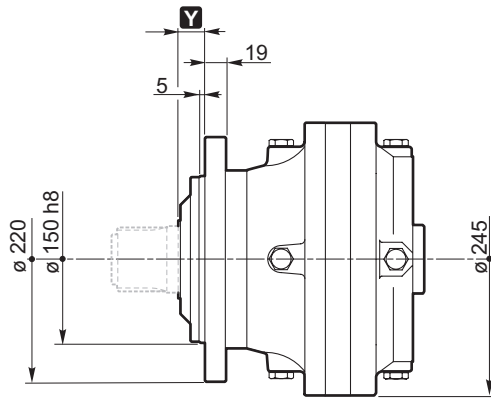
| | | | |
|-------|----|---|----|
| RR710 | .. | i | .. |
| RA710 | .. | | .. |

- MS** 
- MC** 
- MH** 



- SS** 
- SC** 
- SE** 

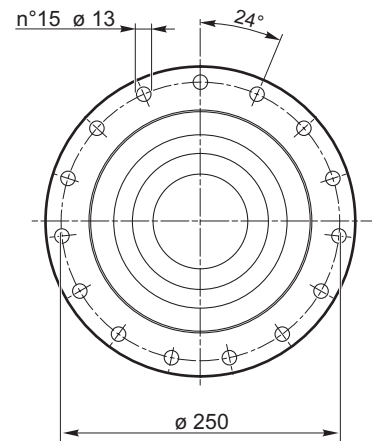
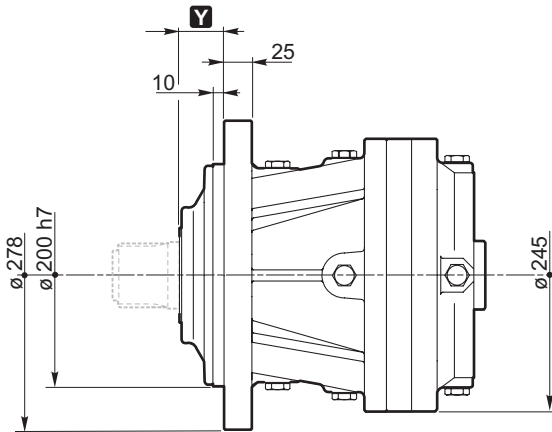

- UC** 

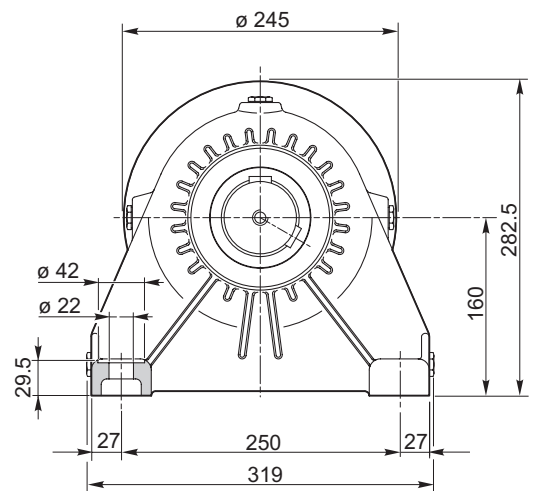
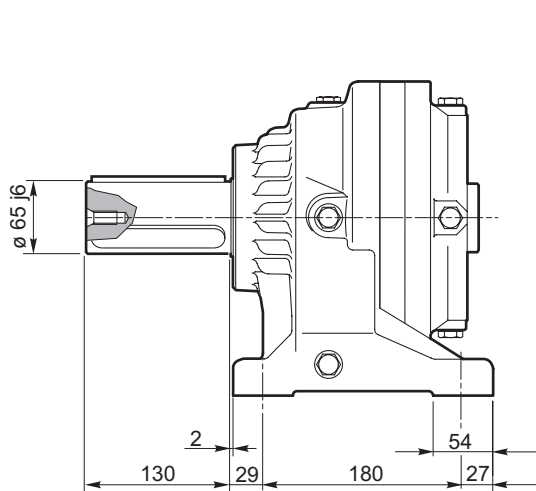

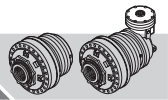

MS

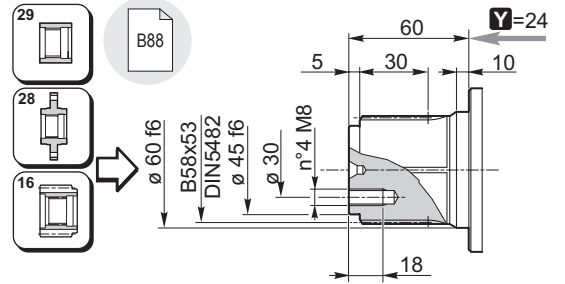
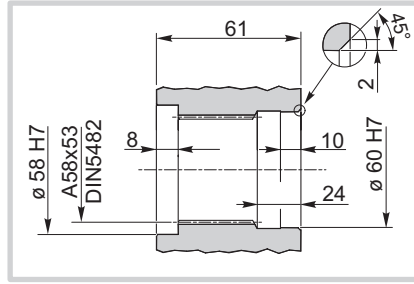
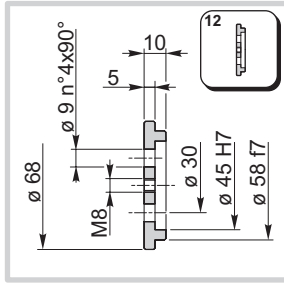

SS

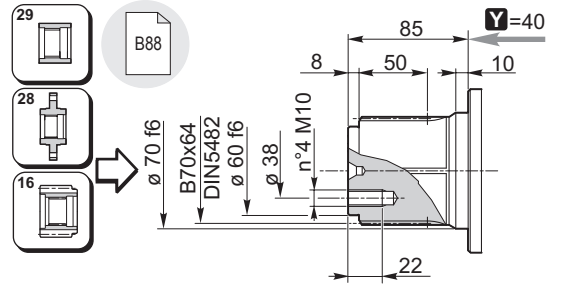
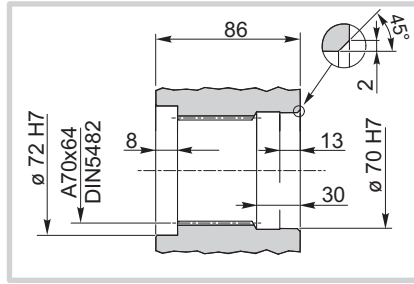
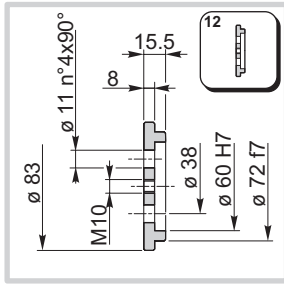

MC
SC
UC

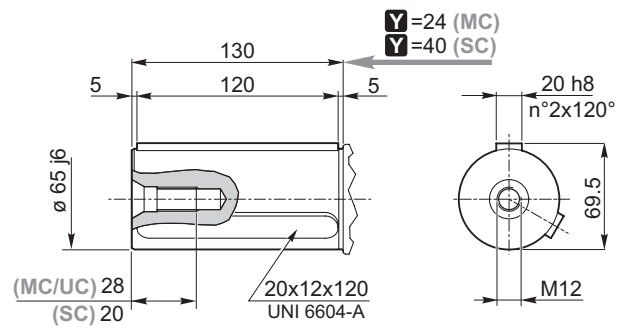
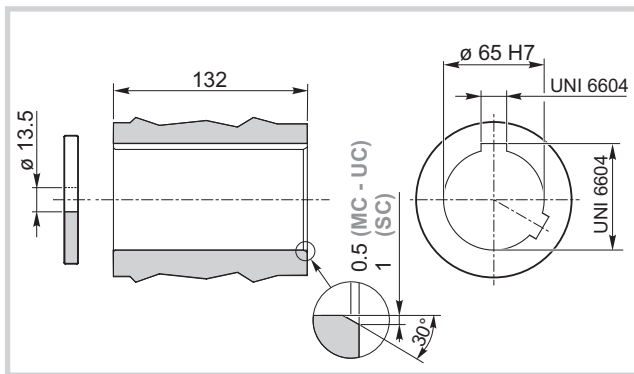

MH

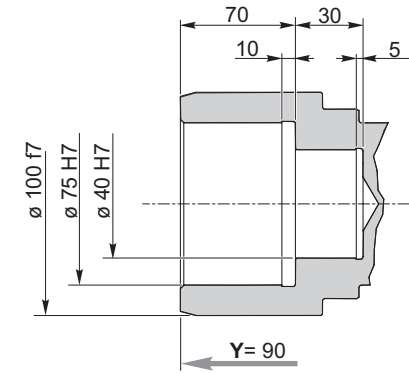
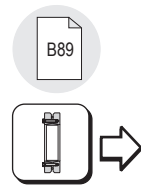
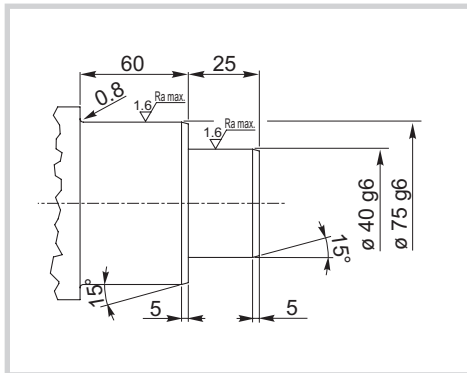

SE

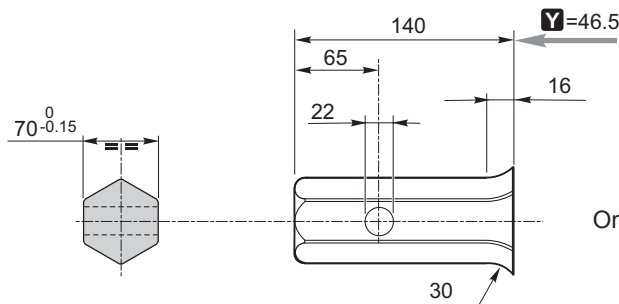

Only for RR710

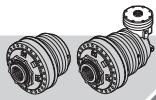

710

IT EN DEFRES PT

RR710 .. i ..

SI

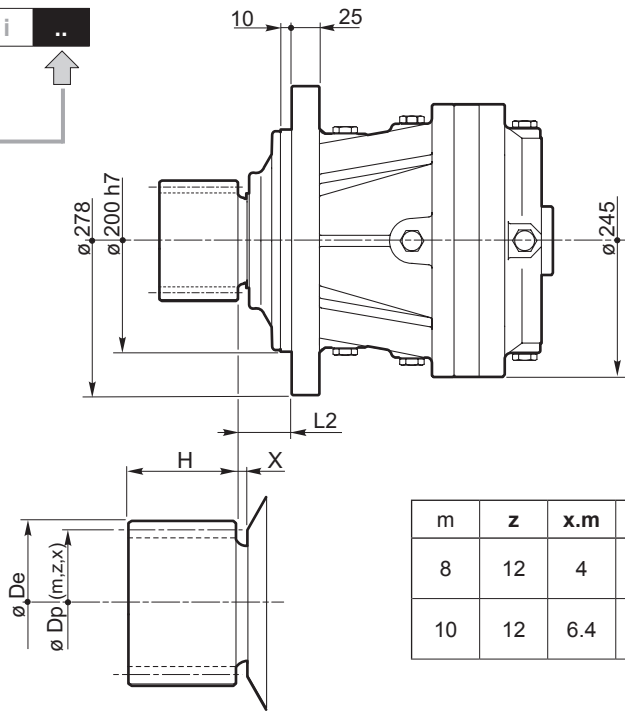

| m | z | x.m | H | Dp | De | L2 | X | code | |
|----|----|-----|----|-----|-----|----|---|--------|----------|
| 8 | 12 | 4 | 70 | 96 | 118 | 45 | 7 | 03-095 | 154F3333 |
| 10 | 12 | 6.4 | 80 | 120 | 149 | 44 | 6 | 03-236 | 154B3948 |

VI

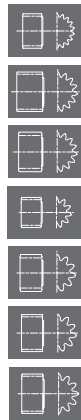
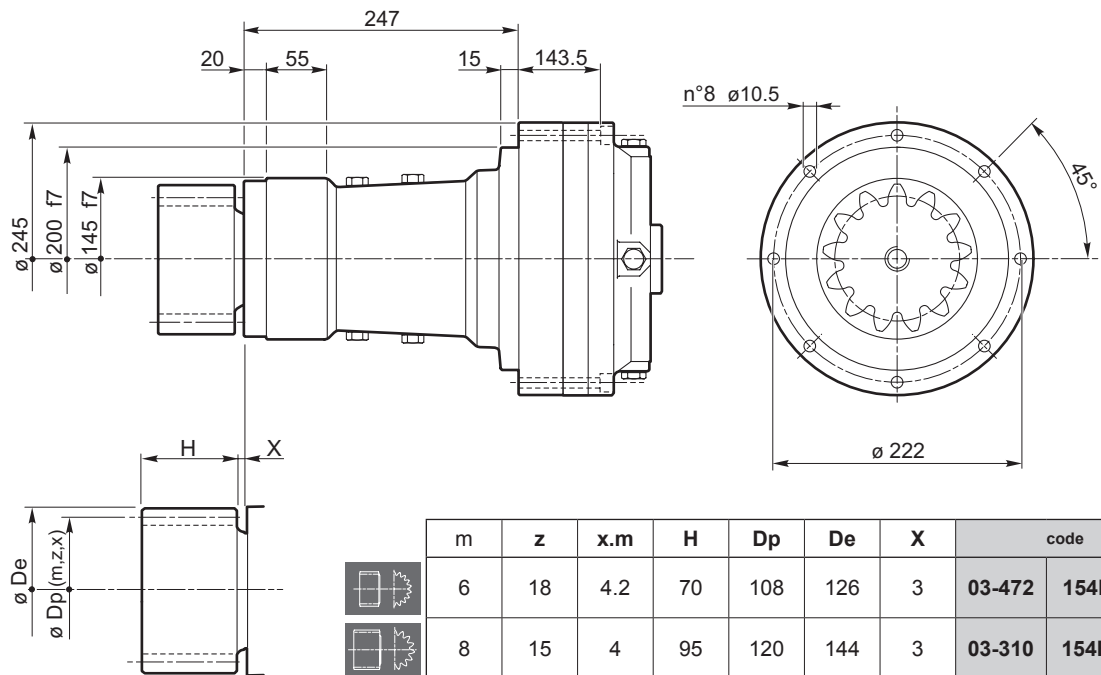

| m | z | x.m | H | Dp | De | X | code | |
|----|----|------|----|-----|-------|---|--------|----------|
| 6 | 18 | 4.2 | 70 | 108 | 126 | 3 | 03-472 | 154F1663 |
| 8 | 15 | 4 | 95 | 120 | 144 | 3 | 03-310 | 154B2443 |
| 8 | 15 | 5 | 85 | 120 | 144.5 | 3 | 03-365 | 154B4171 |
| 8 | 11 | 3 | 73 | 88 | 110 | 8 | 03-284 | 154-5637 |
| 10 | 11 | 5 | 80 | 110 | 135 | 3 | 03-402 | 154F3597 |
| 10 | 11 | 3.75 | 77 | 110 | 135 | 4 | 03-292 | 154B1799 |
| 10 | 12 | 3.2 | 78 | 120 | 143.8 | 3 | 03-237 | 154-5629 |

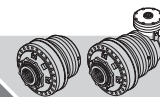

| | | | |
|-------|----|---|-----------|
| RR710 | .. | i | FS |
| RA710 | | | |

FS

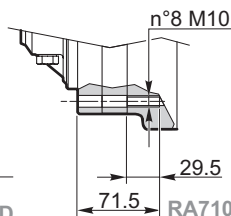
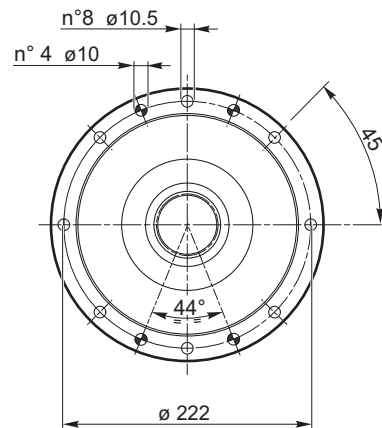
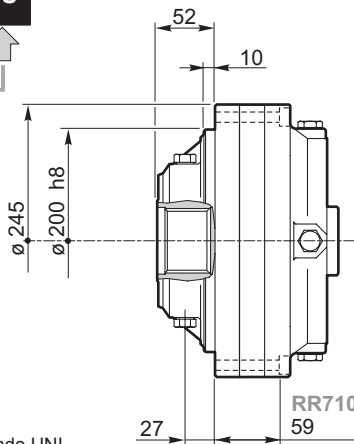

RR710
59
125.5
RR710D RA710D
RR710T RA710T
RR710Q

Trattamento termico:
Tempra ad induzione secondo UNI 10932 su scanalato interno

Heat treatment:
Induction hardening according to UNI 10932 on internal spline

Wärmebehandlung:
Induktionshärtung nach UNI 10932 an interner Nut

Traitement thermique :
Trempe par induction conformément à la norme UNI 10932 sur cannelé interne

Tratamiento térmico:
Temple por inducción según UNI 10932 en acanalado interno

Tratamento térmico:
Tempera por indução segundo UNI 10932 sobre ranhuras internas

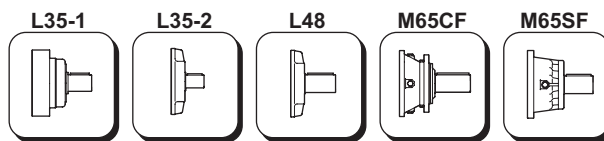
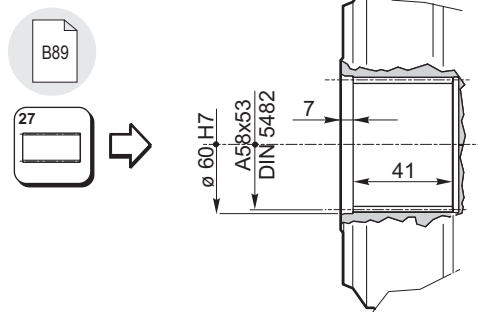
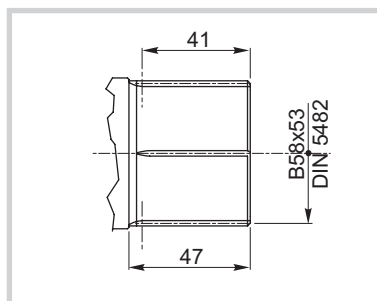

C10

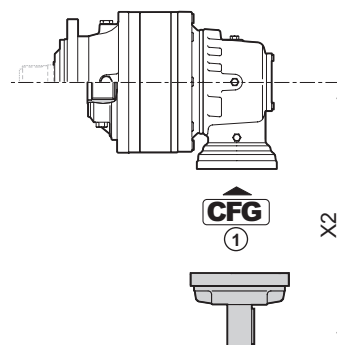
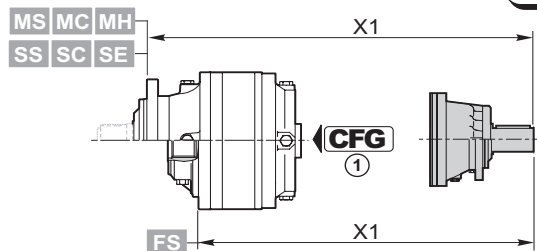

| | CFG ① | | code | X1 |
|--------|----------|-------|------------|--|
| RR710 | RF | M65SF | 154B4249 | 369.5 (M..) 282.5 (FS) 406.5 (S..) |
| | RF | M65CF | 154-2407 | 392 (M..) 305 (FS) 429 (S..) |
| | BOC | L48 | 154B3989 | 306.5 (M..) 219.5 (FS) 343.5 (S..) |
| RR710D | RF | M65SF | 154B4249 | 436 (M..) 349 (FS) 473 (S..) |
| | RF | M65CF | 154-2407 | 459 (M..) 372 (FS) 496 (S..) |
| | BOC | L48 | 154B3989 | 373 (M..) 286 (FS) 410 (S..) |
| RR710T | BOC | L35-2 | 154-2190M1 | 407 (M..) 320 (FS) 444 (S..) |
| RR710Q | RF | L35-1 | 154B4054 | 423 (M..) 336 (FS) 460 (S..) |

| | CFG ① | | code | X2 |
|--------|----------|-------|------------|-------|
| RA710 | BOC | L48 | 154B3989 | 347.5 |
| RA710D | BOC | L35-2 | 154-2190M1 | 270.5 |
| RA710T | BOC | L35-2 | 154-2190M1 | 270.5 |

| CFG | |
|-----|----|
| RF | C3 |
| BOC | C3 |
| A | C3 |
| B | C3 |
| C | C3 |

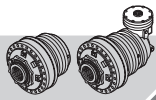

710

IT EN DE FR ES PT

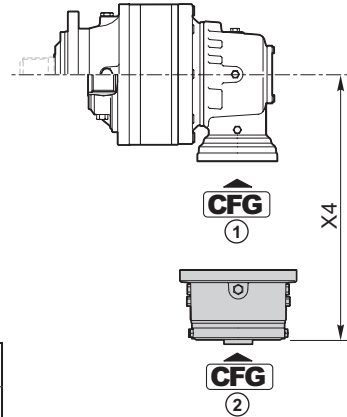
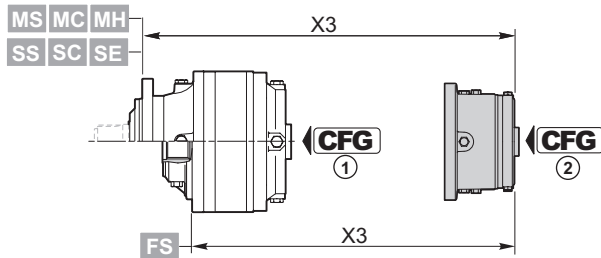
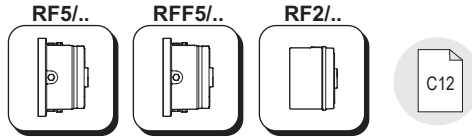

| CFG | |
|-----|----|
| RF | C3 |
| BOC | |
| A | C3 |
| B | |
| C | |

| RF5/.. | CFG ① | T _f [Nm] | CFG ② | | | | | | |
|--------|-------|---------------------|----------|--|----|----------------|----------------|--|----|
| | | | B | | | OMTS 12/24 z16 | OMVS 10/20 z16 | | |
| | | | code | X3 | X4 | code | code | X3 | X4 |
| RR710 | RF | 210 | 154-2872 | 275.5 (M...) 188.5 (FS) 312.5 (S...) | — | 154-2879 | 154-2886 | 279.2 (M...) 192.2 (FS) 316.2 (S...) | — |
| | | 290 | 154-2873 | | | 154-2880 | 154-2887 | | |
| | | 430 | 154-2874 | | | 154-2881 | 154-2888 | | |
| | | 650 | 154-2875 | | | 154-2882 | 154-2889 | | |
| | | 850 | 154-2876 | | | 154-2883 | 154-2890 | | |
| | | 1100 | 154-2877 | | | 154-2884 | 154-2891 | | |
| RR710D | RF | 210 | 154-2872 | 342 (M...) 255 (FS) 379 (S...) | — | 154-2879 | 154-2886 | 345.7 (M...) 258.7 (FS) 382.7 (S...) | — |
| | | 290 | 154-2873 | | | 154-2880 | 154-2887 | | |
| | | 430 | 154-2874 | | | 154-2881 | 154-2888 | | |
| | | 650 | 154-2875 | | | 154-2882 | 154-2889 | | |
| | | 850 | 154-2876 | | | 154-2883 | 154-2890 | | |
| | | 1100 | 154-2877 | | | 154-2884 | 154-2891 | | |
| | | 1300 | 154-2878 | | | 154-2885 | 154-2892 | | |

| RFF5/.. | CFG ① | T _f [Nm] | CFG ② | | | | | | |
|---------|-------|---------------------|----------|----|-------|----------------|----------------|----|-------|
| | | | B | | | OMTS 12/24 z16 | OMVS 10/20 z16 | | |
| | | | code | X3 | X4 | code | code | X3 | X4 |
| RA710 | RF | 210 | 154-2893 | — | 316.6 | 154-5338 | 154-5345 | — | 320.5 |
| | | 290 | 154-2894 | | | 154-5339 | 154-5346 | | |
| | | 430 | 154-2895 | | | 154-5340 | 154-5347 | | |
| | | 650 | 154-2896 | | | 154-5341 | 154-5348 | | |
| | | 850 | 154-2897 | | | 154-5342 | 154-5349 | | |
| | | 1100 | 154-2898 | | | 154-5343 | 154-5350 | | |
| | | 1300 | 154-2899 | | | 154-5344 | 154-5351 | | |



| RF2/.. | CFG ① | T _f [Nm] | CFG ② | | | | | | |
|--------|-------|---------------------|------------|--|-----------------------|------------------------|-----------------------|------------------------|--|
| | | | B | | OMP/OMR SAE A 2B Ø 25 | OMP/OMR SAE A 2B 1" 6B | OMP/OMR SAE A 4B Ø 25 | OMP/OMR SAE A 4B 1" 6B | X3 |
| | | | code | X3 | code | code | code | code | |
| RR710D | RF | 70 | 154-2345 | 314.5 (M...) 227.5 (FS) 351.5 (S...) | 154-2345M10 | 154-2345M11 | 154-2345M16 | 154-2345M17 | 304.5 (M...) 217.5 (FS) 341.5 (S...) |
| | | 140 | 154-2346 | | 154-2346M10 | 154-2346M11 | 154-2346M16 | 154-2346M17 | |
| | | 210 | 154-2347 | | 154-2347M10 | 154-2347M11 | 154-2347M16 | 154-2347M17 | |
| | | 320 | 154-2348 | | 154-2348M10 | 154-2348M11 | 154-2348M16 | 154-2348M17 | |
| | | 430 | 154-2349 | | 154-2349M10 | 154-2349M11 | 154-2349M16 | 154-2349M17 | |
| | | 600 | 154B9186 | | 154B9186M10 | 154B9186M11 | 154B9186M16 | 154B9186M17 | |
| RR710T | RF | 70 | 154-2838M1 | 356 (M...) 269 (FS) 393 (S...) | 154-2863 | 154-2863M11 | 154-2635 | 154-2635M11 | 346 (M...) 259 (FS) 383 (S...) |
| | | 140 | 154-2839M1 | | 154-2864 | 154-2864M11 | 154-2636 | 154-2636M11 | |
| | | 210 | 154-2840M1 | | 154-2865 | 154-2865M11 | 154-2637 | 154-2637M11 | |
| | | 320 | 154-2841M1 | | 154-2866 | 154-2866M11 | 154-2638 | 154-2638M11 | |
| | | 430 | 154-2842M1 | | 154-2867 | 154-2867M11 | 154-2639 | 154-2639M11 | |
| | | 600 | 154B8962M1 | | 154B9665 | 154B9665M11 | 154B9666 | 154B9666M11 | |

| | CFG ① | T _f [Nm] | CFG ② | | | | | | |
|--------|-------|---------------------|------------|--------------------------------------|-----------------------|------------------------|-----------------------|------------------------|--|
| | | | A | | OMP/OMR SAE A 2B Ø 25 | OMP/OMR SAE A 2B 1" 6B | OMP/OMR SAE A 4B Ø 25 | OMP/OMR SAE A 4B 1" 6B | X3 |
| | | | code | X3 | code | code | code | code | |
| RR710Q | RF | 70 | 154-2832M1 | 401 (M...) 314 (FS) 438 (S...) | 154-2858M1 | 154-2858M5 | | | 396.5 (M...) 309.5 (FS) 433.5 (S...) |
| | | 140 | 154-2833M1 | | 154-2859M1 | 154-2859M5 | | | |
| | | 210 | 154-2834M1 | | 154-2860M1 | 154-2860M5 | | | |
| | | 320 | 154-2836M1 | | 154-2861M1 | 154-2861M5 | | | |
| | | 430 | 154-2837M1 | | 154-2862M1 | 154-2862M5 | | | |
| | | 600 | 154B8959M1 | | 154B9663M1 | 154B9663M5 | | | |

| | CFG ① | T _f [Nm] | CFG ② | | | | | | |
|--------|-------|---------------------|-------------|-------|-----------------------|------------------------|-----------------------|------------------------|-------|
| | | | B | | OMP/OMR SAE A 2B Ø 25 | OMP/OMR SAE A 2B 1" 6B | OMP/OMR SAE A 4B Ø 25 | OMP/OMR SAE A 4B 1" 6B | X4 |
| | | | code | X4 | code | code | code | code | |
| RA710 | RF | 70 | 154F2991 | 285.3 | | | | | |
| | | 140 | 154F1890 | | | | | | |
| | | 210 | 154F2961 | | | | | | |
| | | 320 | 154B3591 | | | | | | |
| | | 430 | 154B3592 | | | | | | |
| | | 600 | 154F2992 | | | | | | |
| RA710D | RF | 70 | 154-2838M12 | 223.8 | 154-2863M12 | 154-2863M13 | 154-2635M12 | | 213.8 |
| | | 140 | 154-2839M12 | | 154-2864M12 | 154-2864M13 | 154-2636M12 | | |
| | | 210 | 154-2840M12 | | 154-2865M12 | 154-2865M13 | 154-2637M12 | | |
| | | 320 | 154-2841M12 | | 154-2866M12 | 154-2866M13 | 154-2638M12 | | |
| | | 430 | 154-2842M12 | | 154-2867M12 | 154-2867M13 | 154-2639M12 | | |
| | | 600 | 154B8962M12 | | 154B9665M12 | 154B9665M13 | 154B9666M12 | | |
| RA710T | RF | 70 | 154-2838M12 | 223.8 | 154-2863M12 | 154-2863M13 | 154-2635M12 | | 213.8 |
| | | 140 | 154-2839M12 | | 154-2864M12 | 154-2864M13 | 154-2636M12 | | |
| | | 210 | 154-2840M12 | | 154-2865M12 | 154-2865M13 | 154-2637M12 | | |
| | | 320 | 154-2841M12 | | 154-2866M12 | 154-2866M13 | 154-2638M12 | | |
| | | 430 | 154-2842M12 | | 154-2867M12 | 154-2867M13 | 154-2639M12 | | |
| | | 600 | 154B8962M12 | | 154B9665M12 | 154B9665M13 | 154B9666M12 | | |

| | |
|----------------------------------|--|
| CFG | |
| RF BOC | |
| A B C | |

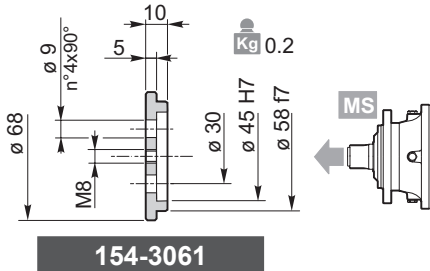
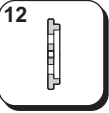
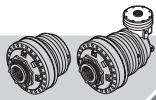

154-3061

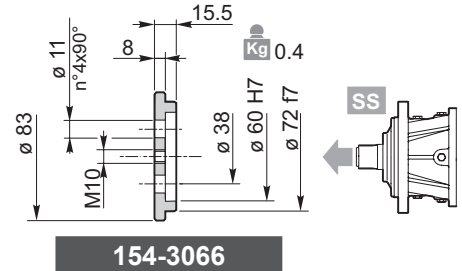

154-3066

Materiale / Material / Material / Matériau / Material / Material:
Acciaio / Steel / Stahl / Acier / Acero / Aço
C40 EN 10083-1 (1.1186)

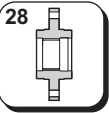

154-3086

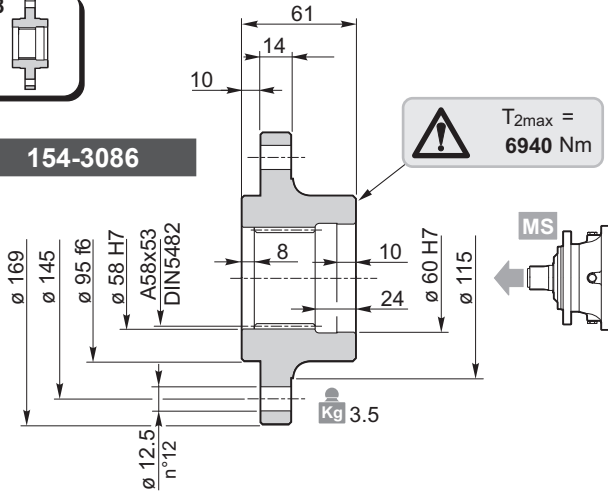

154-3087

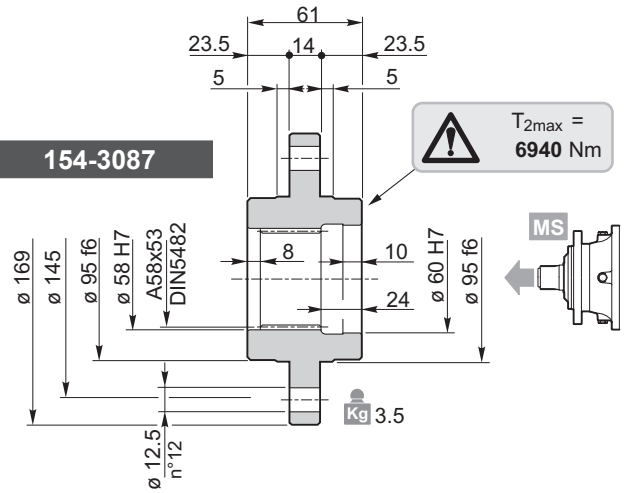

Materiale / Material / Material / Matériau / Material / Material:
Acciaio / Steel / Stahl / Acier / Acero / Aço EN 10083-1-C40 (1.1186)

Trattamento termico:
 Tempra ad induzione secondo UNI 10932 su scanalato interno
Heat treatment:
 Induction hardening according to UNI 10932 on internal spline
Wärmebehandlung:
 Induktionshärtung nach UNI 10932 an interner Nut
Traitement thermique:
 Trempe par induction conformément à la norme UNI 10932 sur cannelé interne
Tratamiento térmico:
 Temple por inducción según UNI 10932 en acanalado interno
Tratamento térmico:
 Tempera por indução segundo UNI 10932 sobre ranhuras internas

154-3114

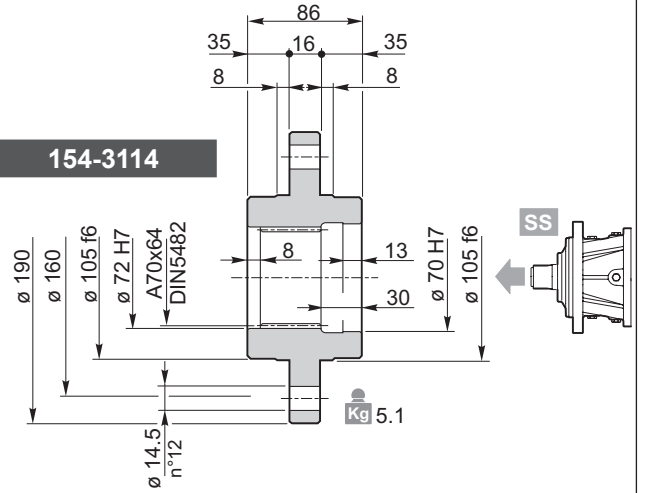

Materiale / Material / Material / Matériau / Material / Material: **Acciaio / Steel / Stahl / Acier / Acero / Aço 39NiCrMo3 UNI 7845 (1.6511)**

Trattamento termico:
 Tempra ad induzione secondo UNI 10932 su scanalato interno
Heat treatment:
 Induction hardening according to UNI 10932 on internal spline
Wärmebehandlung:
 Induktionshärtung nach UNI 10932 an interner Nut

Traitement thermique:
 Trempe par induction conformément à la norme UNI 10932 sur cannelé interne
Tratamiento térmico:
 Temple por inducción según UNI 10932 en acanalado interno
Tratamento térmico:
 Tempera por indução segundo UNI 10932 sobre ranhuras internas

154-3091

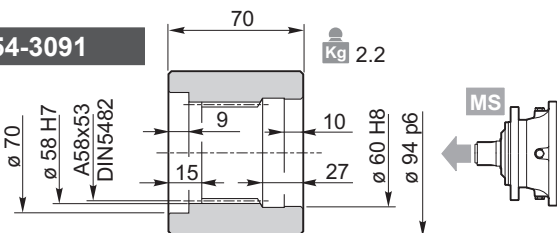

154-3090

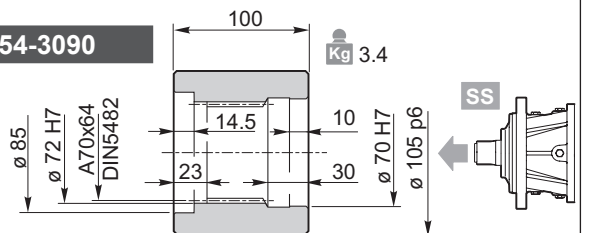

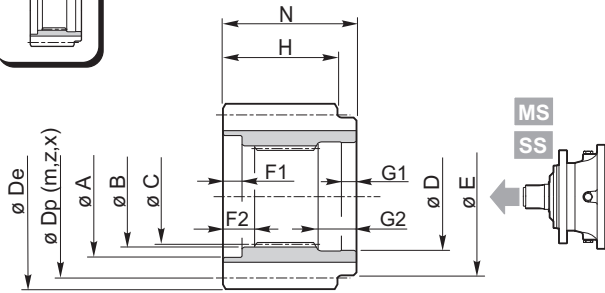
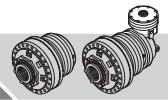

Materiale / Material / Material
 Matériau / Material / Material
 Acciaio / Steel / Stahl / Acier / Acero / Aço
39NiCrMo3 UNI 7845 (1.6511)

Trattamento termico:
 Tempra ad induzione secondo UNI 10932 su scanalato interno

Heat treatment:
 Induction hardening according to UNI 10932 on internal spline

Wärmebehandlung:
 Induktionshärtung nach UNI 10932 an interner Nut

Traitement thermique:
 Trempe par induction conformément à la norme UNI 10932 sur cannelé interne

Tratamiento térmico:
 Temple por inducción según UNI 10932 en acanalado interno

Tratamento térmico:
 Tempera por indução segundo UNI 10932 sobre ranhuras internas

| | A | B | C | D | E | F1 | F2 | G1 | G2 | N | m | z | x | H | Dp | De | Code |
|----|----|-------|-------------------|-------|----|-----|----|----|----|----|-----|----|--------|----|-----|-------|----------|
| MS | 70 | 58 H7 | DIN5482 A58x53 | 60 H7 | 72 | 7 | 13 | 12 | 27 | 68 | 4.5 | 18 | 0.4444 | 65 | 81 | 93 | 154-3106 |
| | 70 | 58 H7 | DIN5482 A58x53 | 60 H7 | 68 | 7 | 13 | 10 | 27 | 68 | 5 | 17 | 0.4 | 65 | 85 | 98 | 154-2287 |
| | 70 | 58 H7 | DIN5482 A58x53 | 60 H7 | 68 | 7 | 13 | 10 | 27 | 68 | 5 | 19 | 0 | 65 | 95 | 104 | 154-2286 |
| | 70 | 58 H7 | DIN5482 A58x53 | 60 H7 | 75 | 7 | 13 | 12 | 27 | 68 | 6 | 14 | 0.5 | 65 | 84 | 101.5 | 154-3082 |
| | 70 | 58 H7 | DIN5482 A58x53 | 60 H7 | 68 | 7 | 13 | 10 | 27 | 68 | 6 | 15 | 0.25 | 65 | 90 | 103 | 154-3107 |
| | 70 | 58 H7 | DIN5482 A58x53 | 60 H7 | 68 | 7 | 13 | 10 | 27 | 68 | 6 | 16 | 0.25 | 65 | 96 | 109 | 154-3245 |
| | 70 | 58 H7 | DIN5482 A58x53 | 60 H7 | 78 | 7 | 13 | 12 | 27 | 68 | 8 | 12 | 0.5 | 65 | 96 | 118 | 154-3074 |
| | 70 | 58 H7 | DIN5482 A58x53 | 60 H7 | 68 | 7 | 13 | 10 | 27 | 68 | 8 | 14 | 0 | 65 | 112 | 126 | 154-3250 |
| | 70 | 58 H7 | DIN5482 A58x53 | 60 H7 | 78 | 7 | 13 | 12 | 27 | 68 | 8 | 15 | 0 | 65 | 120 | 136 | 154-3246 |
| | 70 | 58 H7 | DIN5482 A58x53 | 60 H7 | 68 | 7 | 13 | 10 | 27 | 68 | 8 | 15 | 0.25 | 65 | 120 | 138 | 154-3235 |
| | 70 | 58 H7 | DIN5482 A58x53 | 60 H7 | 78 | 7 | 13 | 12 | 27 | 68 | 8 | 18 | 0 | 65 | 144 | 158 | 154-3103 |
| | 70 | 58 H7 | DIN5482 A58x53 | 60 H7 | 78 | 7 | 13 | 12 | 27 | 68 | 10 | 10 | 0.25 | 65 | 100 | 124.5 | 154-3075 |
| | 70 | 58 H7 | DIN5482 A58x53 | 60 H7 | 78 | 7 | 13 | 12 | 27 | 68 | 10 | 12 | 0.475 | 65 | 120 | 149.5 | 154-3105 |
| | 70 | 58 H7 | DIN5482 A58x53 | 60 H7 | 68 | 7 | 13 | 10 | 27 | 68 | 10 | 15 | 0 | 65 | 150 | 167 | 154-3248 |
| SS | 85 | 72 H7 | DIN5482 A70x64 | 70 H7 | 90 | 7.5 | 16 | 10 | 30 | 93 | 8 | 17 | 0 | 85 | 136 | 149.5 | 154-2290 |
| | 85 | 72 H7 | DIN5482 A70x64 | 70 H7 | 90 | 7.5 | 16 | 10 | 30 | 93 | 10 | 13 | 0.4 | 85 | 130 | 157 | 154-3249 |
| | 85 | 72 H7 | DIN5482 A70x64 | 70 H7 | 90 | 7.5 | 16 | 10 | 30 | 93 | 10 | 14 | 0 | 85 | 140 | 156 | 154-3247 |
| | 85 | 72 H7 | DIN5482 A70x64 | 70 H7 | 90 | 7.5 | 16 | 10 | 30 | 93 | 10 | 15 | 0.7 | 85 | 150 | 179 | 154-2291 |

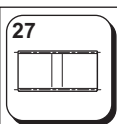

Kg 3.3

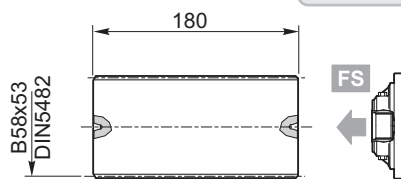

154-3052

Materiale / Material / Material
 Matériau / Material / Material:
 Acciaio / Steel / Stahl / Acier / Acero / Aço
39NiCrMo3 UNI 7845 (1.6511)

T_{2max} = 8100 Nm

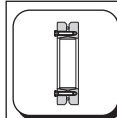

Kg 4.7

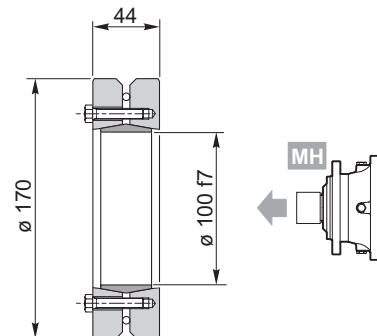

154B3090

C36

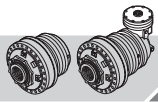

710

IT EN DE FR ES PT

| | | | |
|----|-----|----|-----------|
| RR | 710 | .. | MS |
| RA | | | MC |

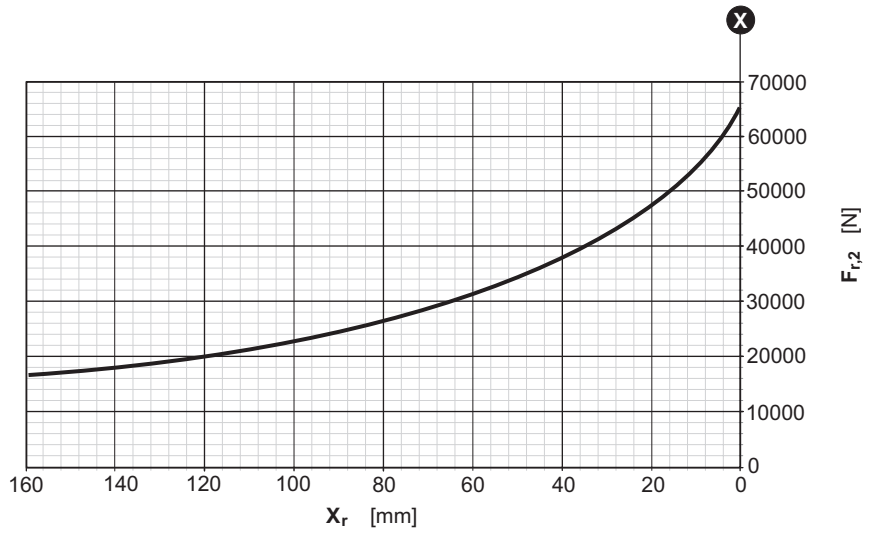
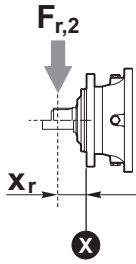

| | | | |
|----|-----|----|-----------|
| RR | 710 | .. | SS |
| RA | | | SC |
| | | | SE |

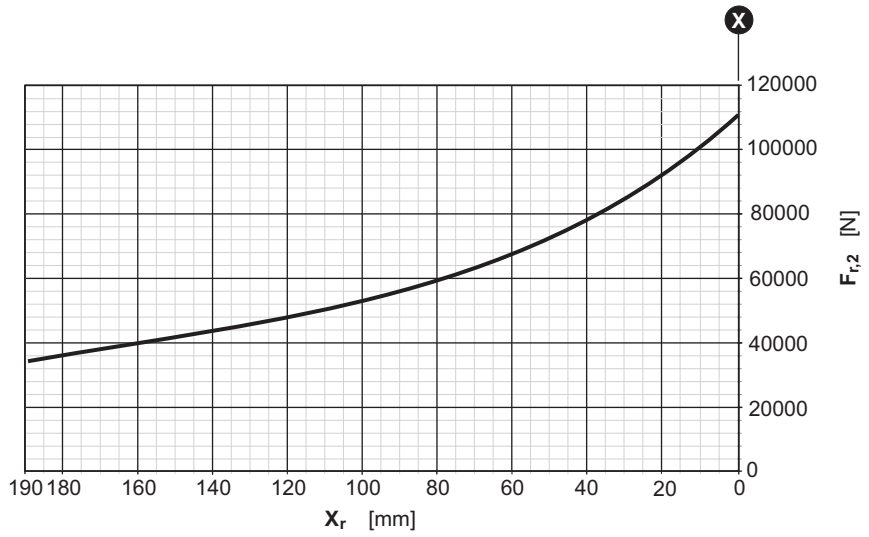
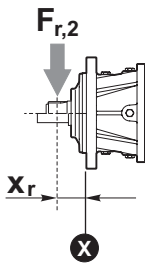

| | | | |
|----|-----|----|-----------|
| RR | 710 | .. | UC |
| RA | | | |

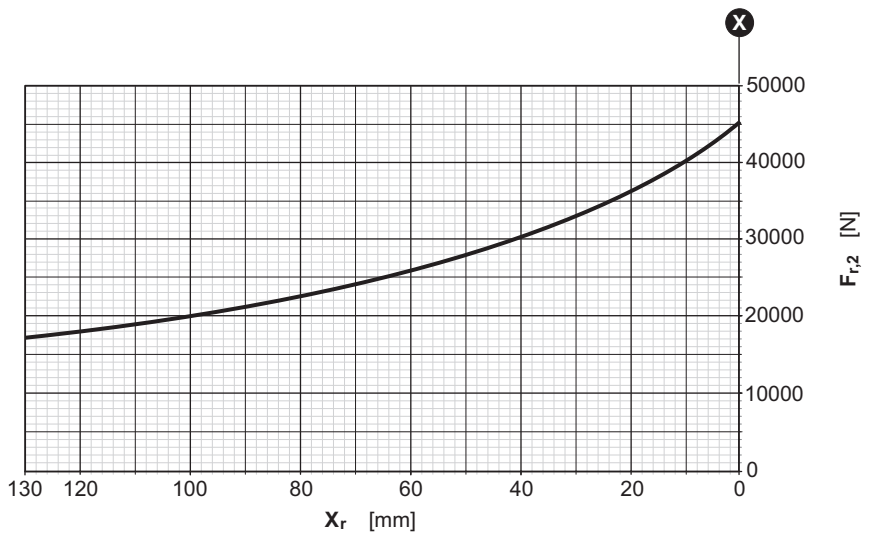
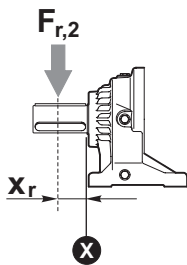

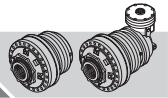

RR 710 .. SI

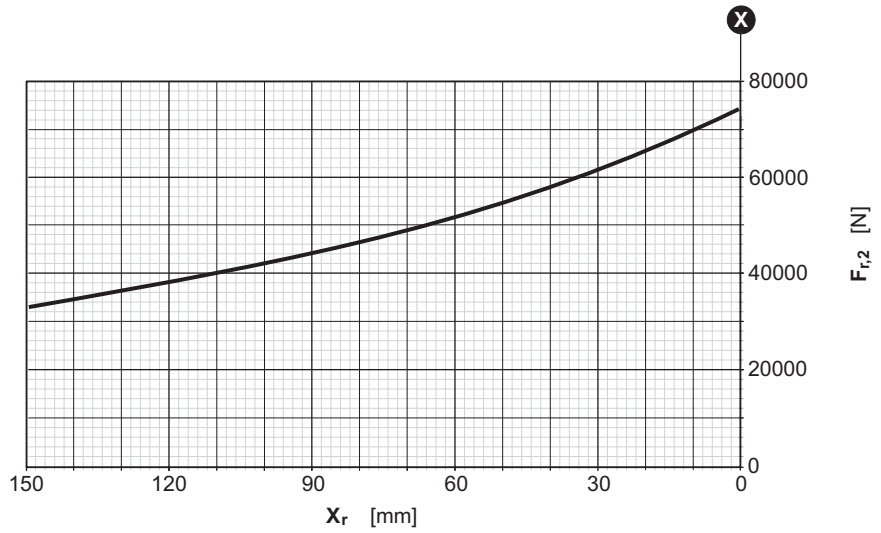
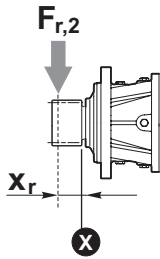

RR 710 .. VI

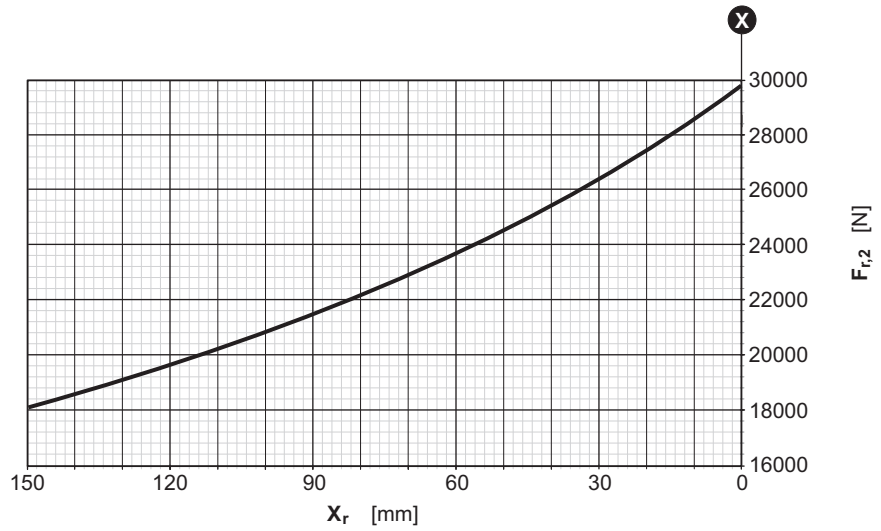
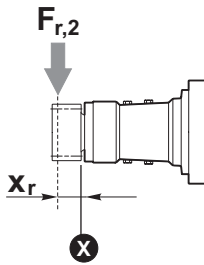

Fattore correttivo $k_{r,2}$ / $k_{r,2}$ Corrective coefficient / Korrekturfaktor $k_{r,2}$
 Facteur correctif $k_{r,2}$ / Factor de corrección $k_{r,2}$ / Fator corretivo $k_{r,2}$

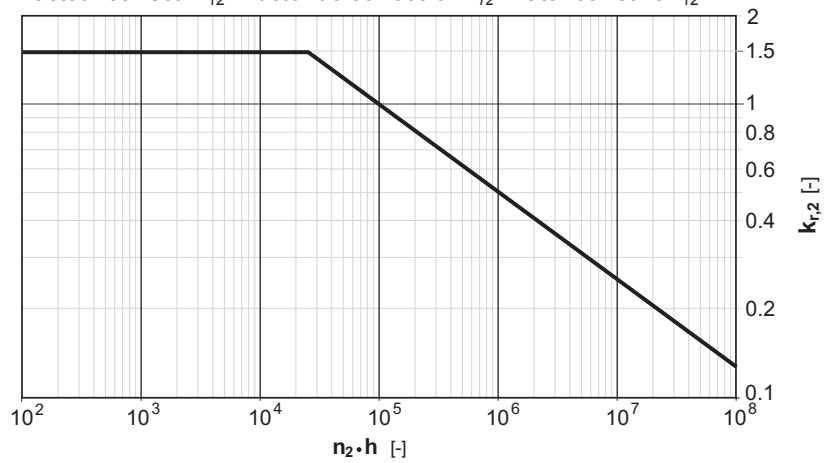



810

IT EN DE FR ES PT

RR810 .. **i**



| i | T ₂ [Nm] | | | | | | n _{1max} [min ⁻¹] | T _{2max} [Nm] | P _t [kW] |
|---------------|-----------------------------|-----------------------------------|---------------------------------|------------------------------|----------------------------------|-------------------------------|---|---------------------------|------------------------|
| | n ₂ x h | | | | | | | | |
| 1/... | 10000 (10 ⁴) | 25000 (2.5 · 10 ⁴) | 50000 (5 · 10 ⁴) | 100000 (10 ⁵) | 500000 (5 · 10 ⁵) | 1000000 (10 ⁶) | | | |
| RR810 | 3.92 | 11560 | 10700 | 10560 | 10410 | 7540 | 3000 | 14500 | 35 |
| | 4.30 | 11230 | 10350 | 10210 | 10210 | 7530 | | | |
| | 5.47 | 10400 | 8900 | 7830 | 7300 | 6620 | | | |
| | 6.43 | 8580 | 7240 | 6360 | 6080 | 5510 | | | |
| | 7.90 | 5550 | 4680 | 4220 | 4050 | 3670 | | | |
| | 8.60 | 4850 | 4080 | 3730 | 3570 | 3100 | | | |
| RR810D | 14.62 | 11230 | 10350 | 10210 | 9800 | 6810 | 3500 | 14500 | 21 |
| | 17.20 | 11230 | 10350 | 10210 | 9800 | 6700 | | | |
| | 21.50 | 9470 | 8430 | 8080 | 7740 | 6530 | | | |
| | 27.35 | 10400 | 8900 | 7830 | 7300 | 6620 | | | |
| | 31.73 | 10120 | 8900 | 7830 | 7300 | 6620 | | | |
| | 38.29 | 7960 | 7530 | 7220 | 6920 | 6270 | | | |
| | 45.00 | 8580 | 7240 | 6360 | 6080 | 5510 | | | |
| | 55.30 | 5550 | 4680 | 4220 | 4050 | 3670 | | | |
| | 60.20 | 4850 | 4080 | 3730 | 3570 | 3100 | | | |
| RR810T | 55.21 | 11230 | 10350 | 10210 | 9800 | 6500 | | | |
| | 70.52 | 11230 | 10350 | 10210 | 9800 | 6280 | | | |
| | 88.15 | 9470 | 8430 | 8080 | 7740 | 6530 | | | |
| | 116.53 | 9470 | 8430 | 8080 | 7740 | 6530 | | | |
| | 154.80 | 9470 | 8430 | 8080 | 7740 | 6530 | | | |
| | 171.95 | 10120 | 8900 | 7830 | 7300 | 6620 | | | |
| | 228.43 | 10120 | 8900 | 7830 | 7300 | 6620 | | | |
| | 275.69 | 7960 | 7530 | 7220 | 6920 | 6270 | | | |
| | 323.97 | 8580 | 7240 | 6360 | 6080 | 5510 | | | |
| | 398.16 | 5550 | 4680 | 4220 | 4050 | 3670 | | | |
| | 433.44 | 4850 | 4080 | 3730 | 3570 | 3100 | | | |
| RR810Q | 247.53 | 11230 | 10350 | 10210 | 9800 | 6280 | 3500 | 14500 | 13 |
| | 327.92 | 11230 | 10350 | 10210 | 9800 | 6280 | | | |
| | 409.90 | 9470 | 8430 | 8080 | 7740 | 6530 | | | |
| | 547.41 | 9470 | 8430 | 8080 | 7740 | 6530 | | | |
| | 723.65 | 9470 | 8430 | 8080 | 7740 | 6530 | | | |
| | 920.55 | 10400 | 8900 | 7830 | 7300 | 6620 | | | |
| | 1067.84 | 10120 | 8900 | 7830 | 7300 | 6620 | | | |
| | 1418.53 | 10120 | 8900 | 7830 | 7300 | 6620 | | | |
| | 1712.02 | 7960 | 7530 | 7220 | 6920 | 6270 | | | |
| | 2011.86 | 8580 | 7240 | 6360 | 6080 | 5510 | | | |
| | 2472.57 | 5550 | 4680 | 4220 | 4050 | 3670 | | | |
| | 2691.66 | 4850 | 4080 | 3730 | 3570 | 3100 | | | |

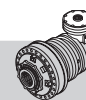

RA810 .. **i**



| | i | T ₂ [Nm] | | | | | | n _{1max} [min ⁻¹] | T _{2max} [Nm] | P _t [kW] |
|---------------|---|--|--|--|--|--|--|---|---------------------------|------------------------|
| | | n ₂ x h | | | | | | | | |
| | | 10000 (10 ⁴) | 25000 (2.5 · 10 ⁴) | 50000 (5 · 10 ⁴) | 100000 (10 ⁵) | 500000 (5 · 10 ⁵) | 1000000 (10 ⁶) | | | |
| RA810 | 17.20 21.88 25.71 31.60 34.40 | 7170 9070 8580 5550 4850 | 6430 7820 7240 4680 4080 | 5700 7120 6360 4220 3730 | 5430 6800 6080 4050 3570 | 4070 4820 5390 3670 3230 | 3310 3910 4380 3510 3100 | 3500 | 14500 | 33 |
| RA810D | 47.08 55.38 69.23 88.07 102.16 123.29 144.89 178.07 193.84 202.55 219.52 225.45 232.58 253.18 264.94 293.69 325.61 354.46 | 6430 7340 8790 10400 10120 7960 8580 5550 4850 4850 5470 5610 5550 4850 6500 4850 5550 4850 | 5620 6540 8040 8900 8900 7530 7240 4680 4080 4080 5080 5210 4680 4080 6040 4080 4680 4080 | 5340 6210 7640 7830 7830 7220 6360 4220 3730 3730 4800 4920 4220 3730 5710 3730 4220 3730 | 5080 5900 7260 7300 7300 6920 6080 4050 3570 3570 4540 4650 4050 3570 5390 3570 4050 3570 | 3420 3830 4480 5300 5880 6270 5510 3670 3230 3230 3980 4080 3670 3230 4730 3230 3670 3230 | 2780 3110 3640 4300 4770 5450 5280 3510 3100 3100 3850 3950 3510 3100 4640 3100 3510 3100 | 3500 | 14500 | 19 |
| RA810T | 177.78 227.07 283.84 375.23 498.46 553.69 735.54 887.72 1043.19 1282.08 1395.68 1435.96 1580.54 1623.25 1764.79 1822.92 2114.59 2344.37 2552.09 | 11230 11230 9470 9470 9470 10120 10120 7960 8580 5550 4850 8580 8580 7960 5550 4850 4850 5550 4850 | 10350 10350 8430 8430 8430 8900 8900 7530 7240 4680 4080 7240 7240 7530 4680 4080 4080 4680 4080 | 10210 10210 8080 8080 8080 7830 7830 7220 6360 4220 3730 6360 6360 7220 4050 3730 3730 4220 3730 | 9800 9800 7740 7740 7740 7300 7300 6920 6080 4050 3570 6080 6080 6920 3670 3570 3570 4050 3570 | 6500 6280 6530 6530 6530 6620 6620 6270 5510 3670 3230 5510 5510 6270 3670 3230 3230 3670 3230 | 5280 5100 5310 5310 5310 5940 5940 5940 5280 3510 3100 5280 5280 5940 3510 3100 3100 3510 3100 | 3500 | 14500 | 15 |



RR810 .. i ..

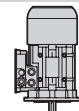
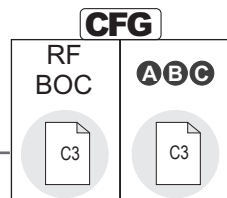
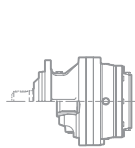
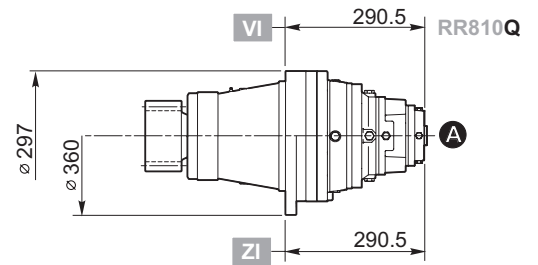
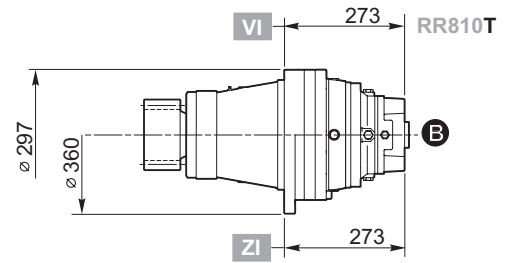
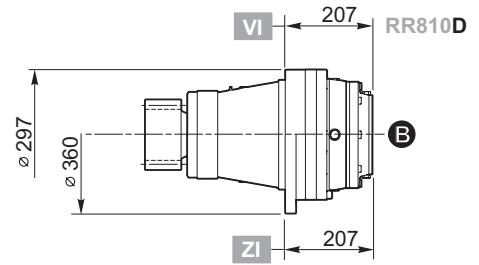
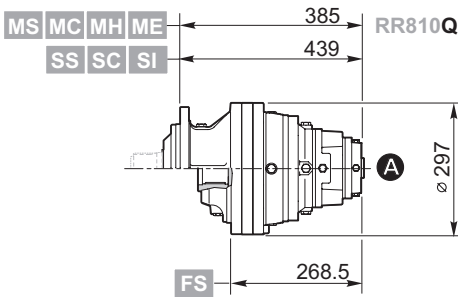
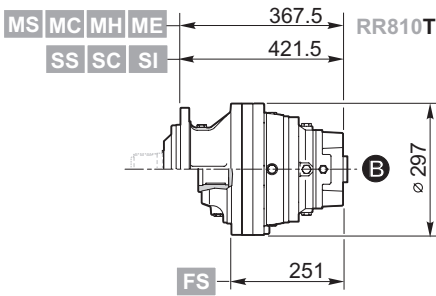
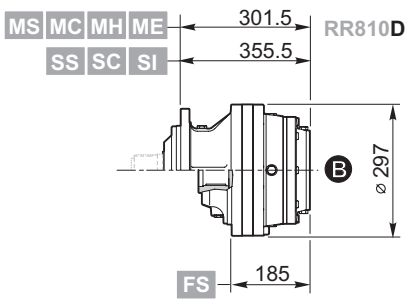
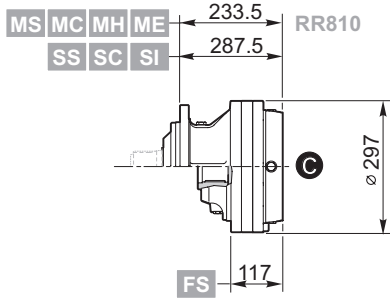

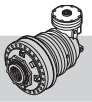

RA810 .. i ..

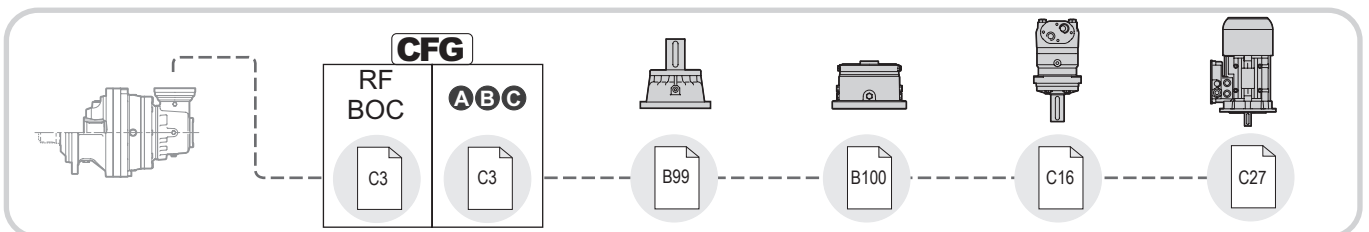
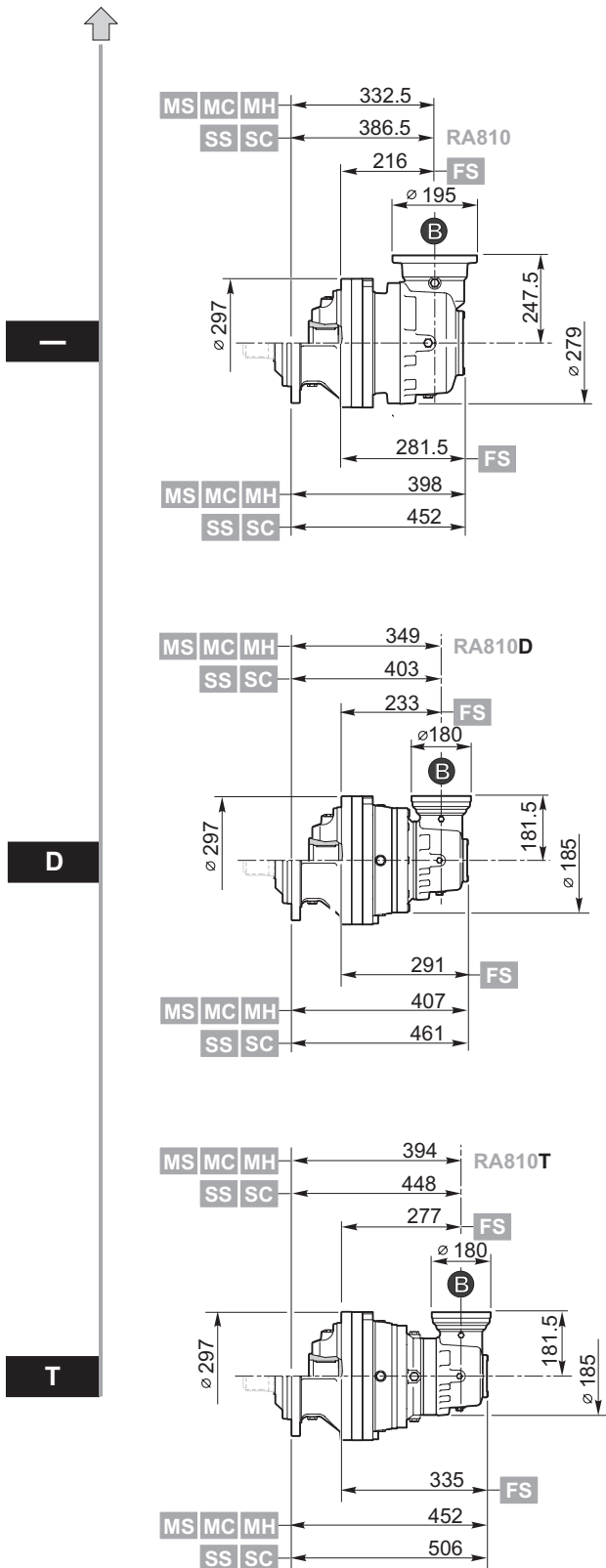

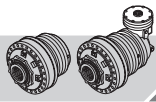





810

IT EN DE FR ES PT

| | | | |
|-------|----|---|----|
| RR810 | .. | i | .. |
| RA810 | .. | | .. |

- MS 
- MC 
- MH 
- ME 

- SS 
- SC 

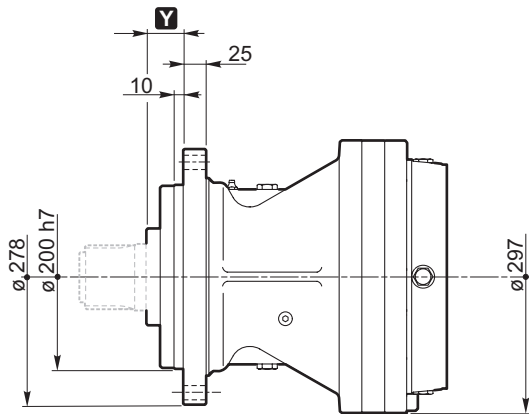
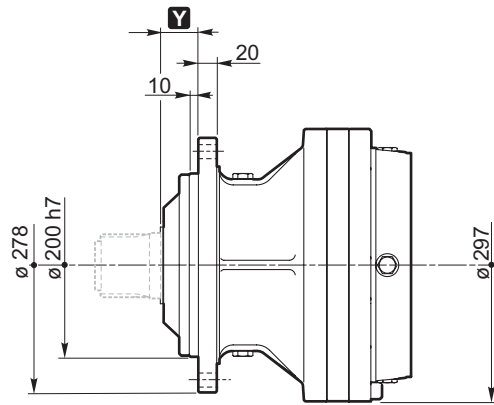

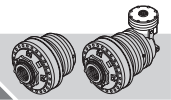

MS
SS

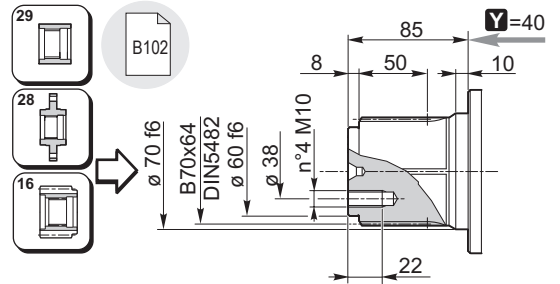
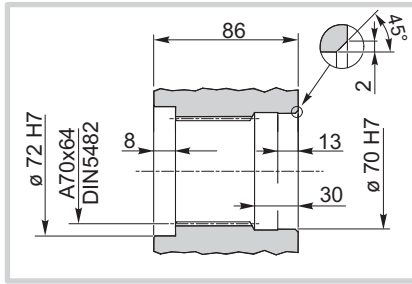
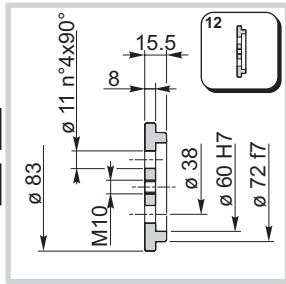

MC
SC

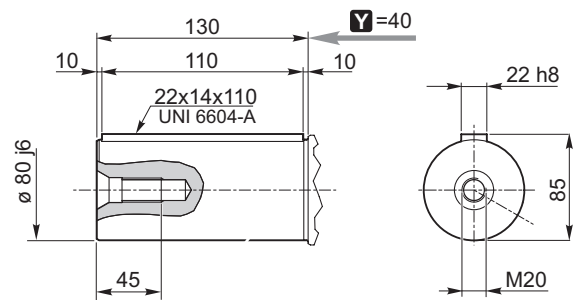
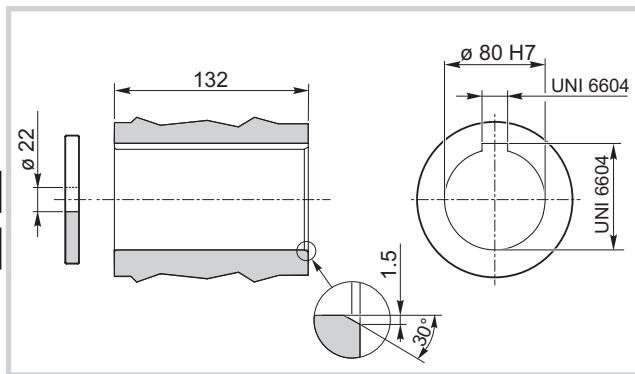

MH

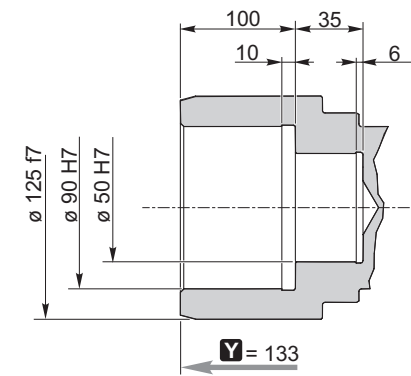
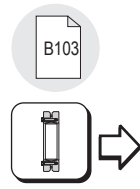
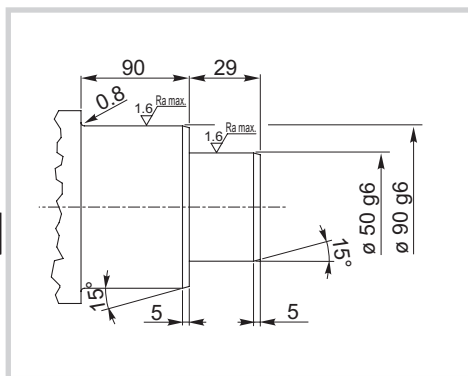

ME

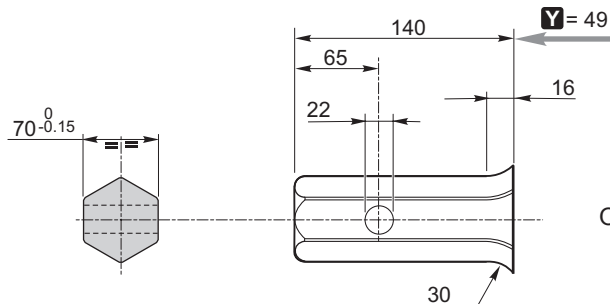

Only for RR810

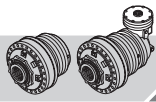

810

IT EN DEFRES PT

RR810 .. i ..

SI

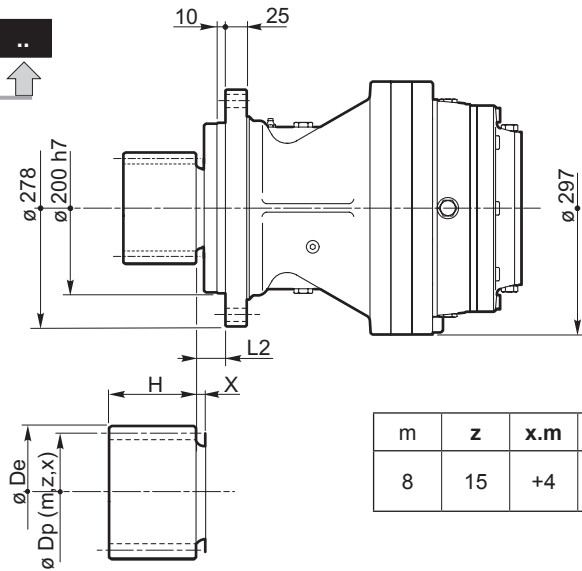

| m | z | x.m | H | Dp | De | L2 | X | code | |
|---|----|-----|------|-----|-----|----|----|--------|----------|
| 8 | 15 | +4 | 73.5 | 120 | 144 | 40 | 15 | 03-366 | 154B4175 |

VI

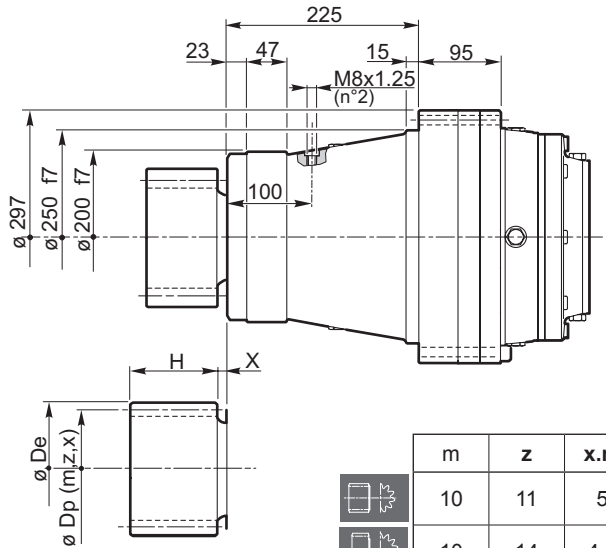

| m | z | x.m | H | Dp | De | X | code | |
|----|----|-----|----|-----|-----|---|--------|----------|
| 10 | 11 | 5 | 95 | 110 | 136 | 5 | 03-476 | 154F1861 |
| 10 | 14 | 4.8 | 80 | 140 | 168 | 5 | 03-487 | 154F1977 |
| 12 | 13 | 6 | 90 | 156 | 189 | 5 | 03-462 | 154F0804 |

ZI

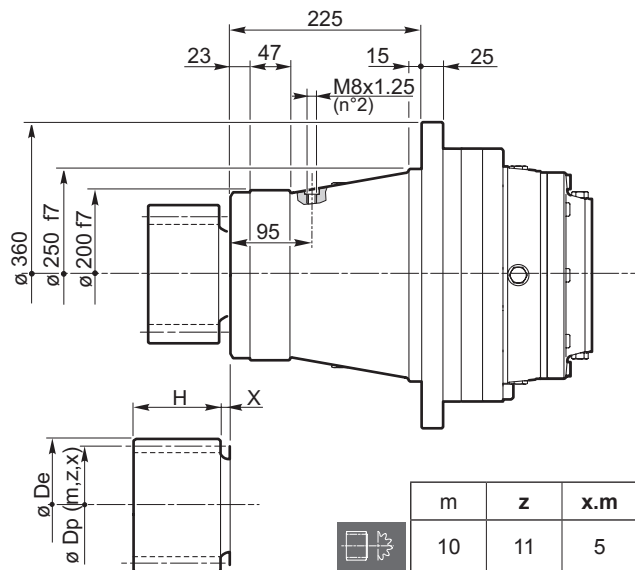

| m | z | x.m | H | Dp | De | X | code | |
|----|----|-----|----|-----|-----|---|--------|----------|
| 10 | 11 | 5 | 95 | 110 | 136 | 5 | 03-476 | 154F1861 |
| 10 | 14 | 4.8 | 80 | 140 | 168 | 5 | 03-487 | 154F1977 |
| 12 | 13 | 6 | 90 | 156 | 189 | 5 | 03-462 | 154F0804 |

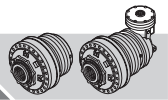

| | | | |
|-------|----|---|-----------|
| RR810 | .. | i | FS |
| RA810 | | | |

FS

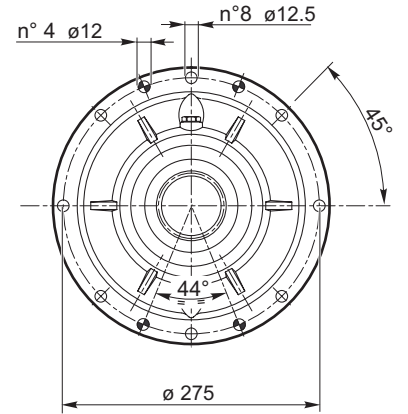
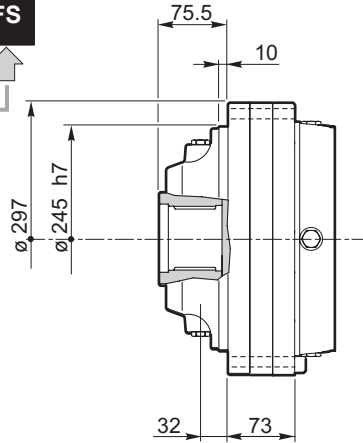

Trattamento termico:
Tempra ad induzione secondo UNI 10932 su scanalato interno

Heat treatment:
Induction hardening according to UNI 10932 on internal spline

Wärmebehandlung:
Induktionshärtung nach UNI 10932 an interner Nut

Traitement thermique :
Trempa par induction conformément à la norme UNI 10932 sur cannelé interne

Tratamiento térmico:
Temple por inducción según UNI 10932 en acanalado interno

Tratamento térmico:
Tempera por indução segundo UNI 10932 sobre ranhuras internas

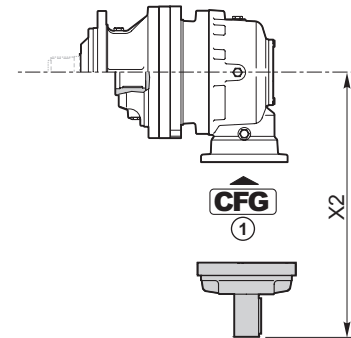
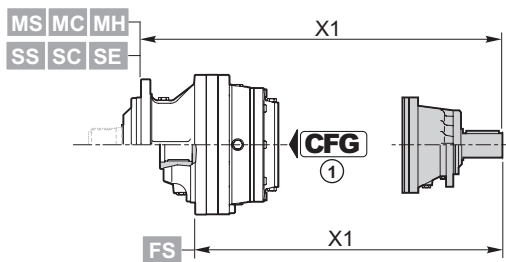
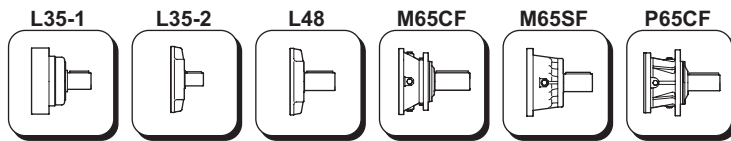
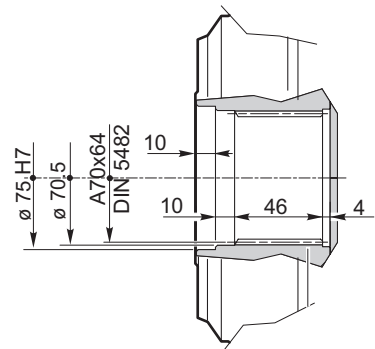
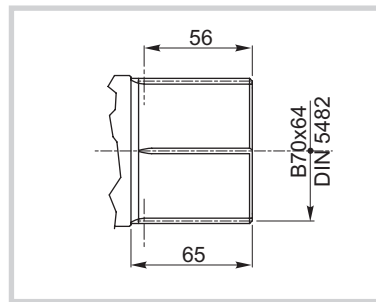

| | CFG ① | | code | X1 |
|---------------|-----------------|--------------|------------|--|
| RR810 | - | P65CF | 154-2404 | 545.5 (M...) 429 (FS) 599 (S...) |
| RR810D | RF | M65SF | 154B4249 | 486 (M...) 369.5 (FS) 540 (S...) |
| | RF | M65CF | 154-2407 | 509 (M...) 392 (FS) 563 (S...) |
| | BOC | L48 | 154B3989 | 423 (M...) 306.5 (FS) 477 (S...) |
| RR810T | BOC | L35-2 | 154-2190M1 | 457 (M...) 340.5 (FS) 511 (S...) |
| RR810Q | RF | L35-1 | 154B4054 | 473 (M...) 356.5 (FS) 527 (S...) |

| | CFG ① | | code | X2 |
|---------------|-----------------|--------------|------------|-------|
| RA810 | BOC | L48 | 154B3989 | 347.5 |
| RA810D | BOC | L35-2 | 154-2190M1 | 270.5 |
| RA810T | BOC | L35-2 | 154-2190M1 | 270.5 |

CFG

RF

BOC

A

B

C



810

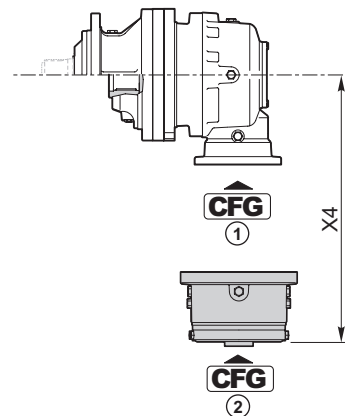
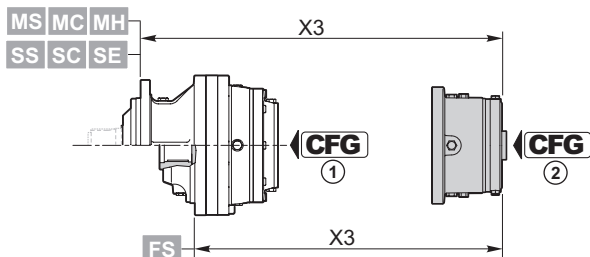
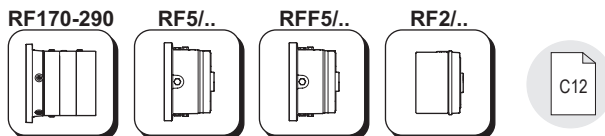

| | |
|------------|--|
| CFG | |
| RF | |
| BOC | |
| A | |
| B | |
| C | |

| RF170÷290 | CFG ① | T _f [Nm] | CFG ② | | |
|-----------|-----------------|------------------------|--------------|--------------------------------------|----|
| | | | C | | |
| | | | code | X3 | X4 |
| RR810 | RF | 1700 | 154B9766M4 | 431 (M...) 314 (FS) 485 (S...) | — |
| | | 2000 | 154B9767M4 | | |
| | | 2300 | 154B9768M4 | | |
| | | 2900 | 154B9769M4 | | |

| RF5/.. | CFG ① | T _f [Nm] | CFG ② | | | | | | |
|--------|-----------------|------------------------|--------------|--|----|-------------------|-------------------|--|----|
| | | | B | | | OMTS 12/24 z16 | OMVS 10/20 z16 | | |
| | | | code | X3 | X4 | code | code | X3 | X4 |
| RR810D | RF | 210 | 154-2872 | 392 (M...) 275.5 (FS) 446 (S...) | — | 154-2879 | 154-2886 | 395.7 (M...) 279.2 (FS) 449.7 (S...) | — |
| | | 290 | 154-2873 | | | 154-2880 | 154-2887 | | |
| | | 430 | 154-2874 | | | 154-2881 | 154-2888 | | |
| | | 650 | 154-2875 | | | 154-2882 | 154-2889 | | |
| | | 850 | 154-2876 | | | 154-2883 | 154-2890 | | |
| | | 1100 | 154-2877 | | | 154-2884 | 154-2891 | | |
| | | 1300 | 154-2878 | | | 154-2885 | 154-2892 | | |

| RFF5/.. | CFG ① | T _f [Nm] | CFG ② | | | | | | |
|---------|-----------------|------------------------|--------------|----|-------|-------------------|-------------------|----|-------|
| | | | B | | | OMTS 12/24 z16 | OMVS 10/20 z16 | | |
| | | | code | X3 | X4 | code | code | X3 | X4 |
| RA810 | RF | 210 | 154-2893 | — | 316.6 | 154-5338 | 154-5345 | — | 320.5 |
| | | 290 | 154-2894 | | | 154-5339 | 154-5346 | | |
| | | 430 | 154-2895 | | | 154-5340 | 154-5347 | | |
| | | 650 | 154-2896 | | | 154-5341 | 154-5348 | | |
| | | 850 | 154-2897 | | | 154-5342 | 154-5349 | | |
| | | 1100 | 154-2898 | | | 154-5343 | 154-5350 | | |
| | | 1300 | 154-2899 | | | 154-5344 | 154-5351 | | |





| RF2/.. | CFG ① | T _f [Nm] | CFG ② | | | | | | |
|--------|-------|---------------------|------------|--|-----------------------|------------------------|-----------------------|------------------------|--|
| | | | B | | OMP/OMR SAE A 2B Ø 25 | OMP/OMR SAE A 2B 1" 6B | OMP/OMR SAE A 4B Ø 25 | OMP/OMR SAE A 4B 1" 6B | X3 |
| | | | code | X3 | code | code | code | code | |
| RR810D | RF | 70 | 154-2345 | 364.5 (M...) 248 (FS) 418.5 (S...) | 154-2345M10 | 154-2345M11 | 154-2345M16 | 154-2345M17 | 354.5 (M...) 238 (FS) 408.5 (S...) |
| | | 140 | 154-2346 | | 154-2346M10 | 154-2346M11 | 154-2346M16 | 154-2346M17 | |
| | | 210 | 154-2347 | | 154-2347M10 | 154-2347M11 | 154-2347M16 | 154-2347M17 | |
| | | 320 | 154-2348 | | 154-2348M10 | 154-2348M11 | 154-2348M16 | 154-2348M17 | |
| | | 430 | 154-2349 | | 154-2349M10 | 154-2349M11 | 154-2349M16 | 154-2349M17 | |
| | | 600 | 154B9186 | | 154B9186M10 | 154B9186M11 | 154B9186M16 | 154B9186M17 | |
| RR810T | RF | 70 | 154-2838M1 | 406 (M...) 289.5 (FS) 460 (S...) | 154-2863 | 154-2863M11 | 154-2635 | 154-2635M11 | 396 (M...) 279.5 (FS) 450 (S...) |
| | | 140 | 154-2839M1 | | 154-2864 | 154-2864M11 | 154-2636 | 154-2636M11 | |
| | | 210 | 154-2840M1 | | 154-2865 | 154-2865M11 | 154-2637 | 154-2637M11 | |
| | | 320 | 154-2841M1 | | 154-2866 | 154-2866M11 | 154-2638 | 154-2638M11 | |
| | | 430 | 154-2842M1 | | 154-2867 | 154-2867M11 | 154-2639 | 154-2639M11 | |
| | | 600 | 154B8962M1 | | 154B9665 | 154B9665M11 | 154B9666 | 154B9666M11 | |

| | CFG ① | T _f [Nm] | CFG ② | | | | | | |
|--------|-------|---------------------|------------|--|-----------------------|------------------------|-----------------------|------------------------|--|
| | | | A | | OMP/OMR SAE A 2B Ø 25 | OMP/OMR SAE A 2B 1" 6B | OMP/OMR SAE A 4B Ø 25 | OMP/OMR SAE A 4B 1" 6B | X3 |
| | | | code | X3 | code | code | code | code | |
| RR810Q | RF | 70 | 154-2832M1 | 451 (M...) 334.5 (FS) 505 (S...) | 154-2858M1 | 154-2858M5 | | | 446.5 (M...) 330 (FS) 500.5 (S...) |
| | | 140 | 154-2833M1 | | 154-2859M1 | 154-2859M5 | | | |
| | | 210 | 154-2834M1 | | 154-2860M1 | 154-2860M5 | | | |
| | | 320 | 154-2836M1 | | 154-2861M1 | 154-2861M5 | | | |
| | | 430 | 154-2837M1 | | 154-2862M1 | 154-2862M5 | | | |
| | | 600 | 154B8959M1 | | 154B9663M1 | 154B9663M5 | | | |

| | CFG ① | T _f [Nm] | CFG ② | | | | | | |
|--------|-------|---------------------|-------------|-------|-----------------------|------------------------|-----------------------|------------------------|-------|
| | | | B | | OMP/OMR SAE A 2B Ø 25 | OMP/OMR SAE A 2B 1" 6B | OMP/OMR SAE A 4B Ø 25 | OMP/OMR SAE A 4B 1" 6B | X4 |
| | | | code | X4 | code | code | code | code | |
| RA810 | RF | 70 | 154F2991 | 285.3 | | | | | — |
| | | 140 | 154F1890 | | | | | | |
| | | 210 | 154F2961 | | | | | | |
| | | 320 | 154B3591 | | | | | | |
| | | 430 | 154B3592 | | | | | | |
| | | 600 | 154F2992 | | | | | | |
| RA810D | RF | 70 | 154-2838M12 | 223.8 | 154-2863M12 | 154-2863M13 | 154-2635M12 | | 213.8 |
| | | 140 | 154-2839M12 | | 154-2864M12 | 154-2864M13 | 154-2636M12 | | |
| | | 210 | 154-2840M12 | | 154-2865M12 | 154-2865M13 | 154-2637M12 | | |
| | | 320 | 154-2841M12 | | 154-2866M12 | 154-2866M13 | 154-2638M12 | | |
| | | 430 | 154-2842M12 | | 154-2867M12 | 154-2867M13 | 154-2639M12 | | |
| | | 600 | 154B8962M12 | | 154B9665M12 | 154B9665M13 | 154B9666M12 | | |
| RA810T | RF | 70 | 154-2838M12 | 223.8 | 154-2863M12 | 154-2863M13 | 154-2635M12 | | 213.8 |
| | | 140 | 154-2839M12 | | 154-2864M12 | 154-2864M13 | 154-2636M12 | | |
| | | 210 | 154-2840M12 | | 154-2865M12 | 154-2865M13 | 154-2637M12 | | |
| | | 320 | 154-2841M12 | | 154-2866M12 | 154-2866M13 | 154-2638M12 | | |
| | | 430 | 154-2842M12 | | 154-2867M12 | 154-2867M13 | 154-2639M12 | | |
| | | 600 | 154B8962M12 | | 154B9665M12 | 154B9665M13 | 154B9666M12 | | |

CFG

RF
BOC 

A
B
C 

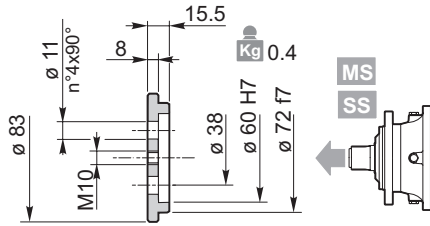
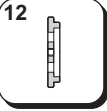
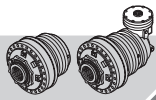

154-3066

Materiale / Material / Material / Matériau / Material / Material:
Acciaio / Steel / Stahl / Acier / Acero / Aço
C40 EN 10083-1 (1.1186)

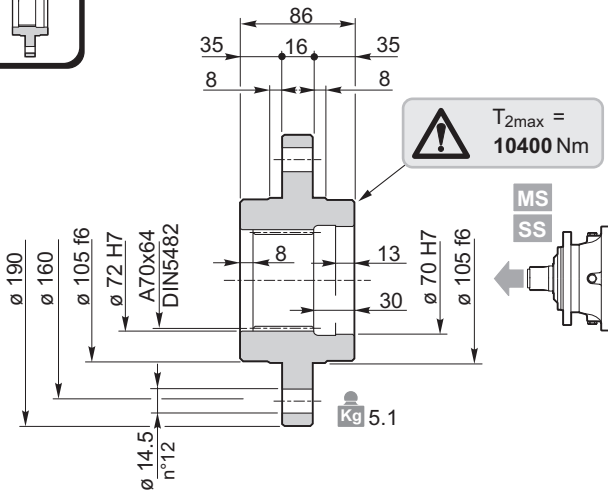
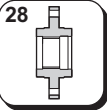

154-3114

Materiale / Material / Material / Matériau / Material / Material:
Acciaio / Steel / Stahl / Acier / Acero / Aço
EN 10083-1-C40 (1.1186)

Trattamento termico:
 Tempra ad induzione secondo UNI 10932 su scanalato interno
Heat treatment:
 Induction hardening according to UNI 10932 on internal spline
Wärmebehandlung:
 Induktionshärtung nach UNI 10932 an interner Nut
Traitement thermique:
 Trempe par induction conformément à la norme UNI 10932 sur cannelé interne
Tratamiento térmico:
 Temple por inducción según UNI 10932 en acanalado interno
Tratamento térmico:
 Tempera por indução segundo UNI 10932 sobre ranhuras internas

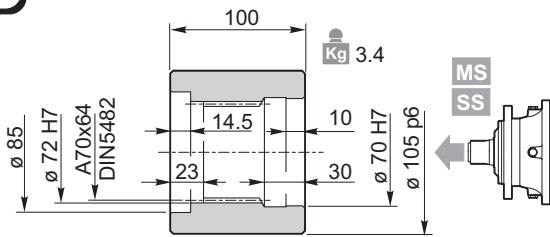

154-3090

Materiale / Material / Material / Matériau / Material / Material:
Acciaio / Steel / Stahl / Acier / Acero / Aço
39NiCrMo3 UNI 7845 (1.6511)

Trattamento termico:
 Tempra ad induzione secondo UNI 10932 su scanalato interno
Heat treatment:
 Induction hardening according to UNI 10932 on internal spline
Wärmebehandlung:
 Induktionshärtung nach UNI 10932 an interner Nut
Traitement thermique:
 Trempe par induction conformément à la norme UNI 10932 sur cannelé interne
Tratamiento térmico:
 Temple por inducción según UNI 10932 en acanalado interno
Tratamento térmico:
 Tempera por indução segundo UNI 10932 sobre ranhuras internas

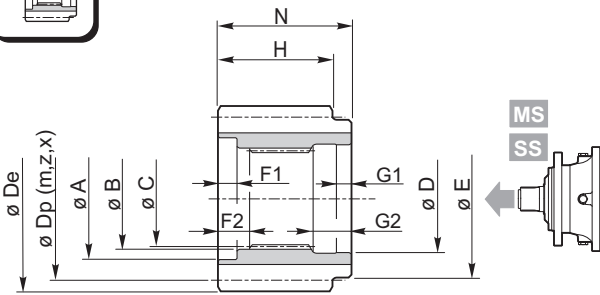
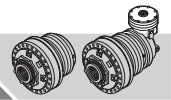

Materiale / Material / Material
 Matériau / Material / Material
 Acciaio / Steel / Stahl / Acier / Acero / Aço
 39NiCrMo3 UNI 7845 (1.6511)

Trattamento termico:
 Tempra ad induzione secondo UNI 10932 su scanalato interno

Heat treatment:
 Induction hardening according to UNI 10932 on internal spline

Wärmebehandlung:
 Induktionshärtung nach UNI 10932 an interner Nut

Traitement thermique :
 Trempe par induction conformément à la norme UNI 10932 sur cannelé interne

Tratamiento térmico:
 Temple por inducción según UNI 10932 en acanalado interno

Tratamento térmico:
 Tempera por indução segundo UNI 10932 sobre ranhuras internas

| | A | B | C | D | E | F1 | F2 | G1 | G2 | N | m | z | x | H | Dp | De | Code |
|----------|----|-------|-------------------|-------|----|-----|----|----|----|----|----|----|-----|----|-----|-------|----------|
| MS SS | 85 | 72 H7 | DIN5482 A70x64 | 70 H7 | 90 | 7.5 | 16 | 10 | 30 | 93 | 8 | 17 | 0 | 85 | 136 | 149.5 | 154-2290 |
| | 85 | 72 H7 | DIN5482 A70x64 | 70 H7 | 90 | 7.5 | 16 | 10 | 30 | 93 | 10 | 13 | 0.4 | 85 | 130 | 157 | 154-3249 |
| | 85 | 72 H7 | DIN5482 A70x64 | 70 H7 | 90 | 7.5 | 16 | 10 | 30 | 93 | 10 | 14 | 0 | 85 | 140 | 156 | 154-3247 |
| | 85 | 72 H7 | DIN5482 A70x64 | 70 H7 | 90 | 7.5 | 16 | 10 | 30 | 93 | 10 | 15 | 0.7 | 85 | 150 | 179 | 154-2291 |

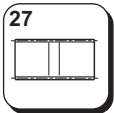

Kg 5.0

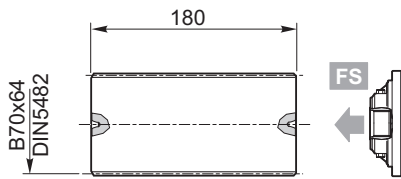

154-3053

Materiale / Material / Material
 Matériau / Material / Material:
 Acciaio / Steel / Stahl / Acier / Acero / Aço
 39NiCrMo3 UNI 7845 (1.6511)

T_{2max} = 14000Nm

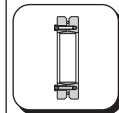

Kg 8.3

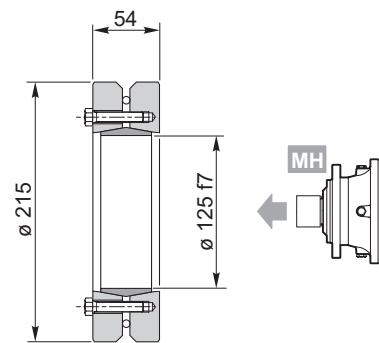

154F4654

C36

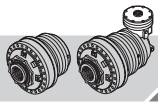

810

IT EN DE FR ES PT

| | | | |
|----|-----|----|-----------|
| RR | 810 | .. | MS |
| RA | | | MC |
| | | | ME |

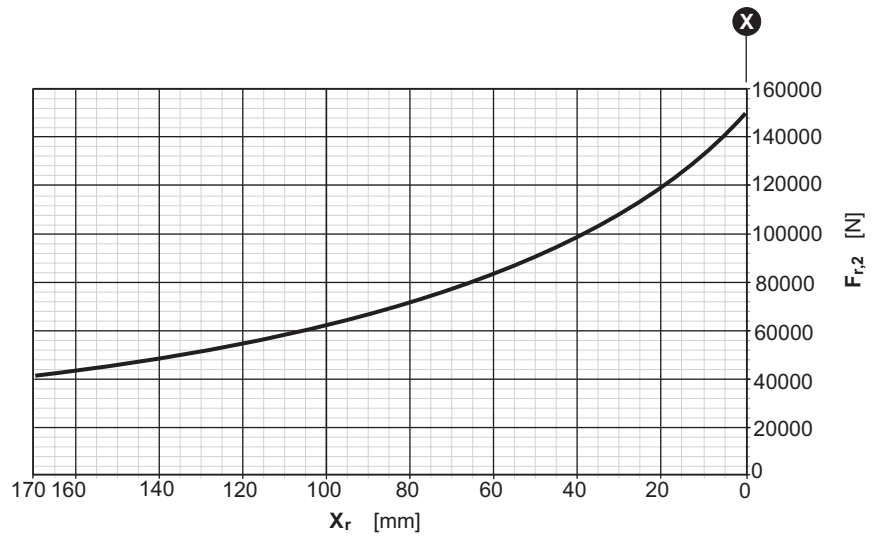
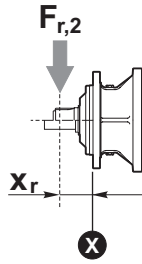

| | | | |
|----|-----|----|-----------|
| RR | 810 | .. | SS |
| RA | | | SC |

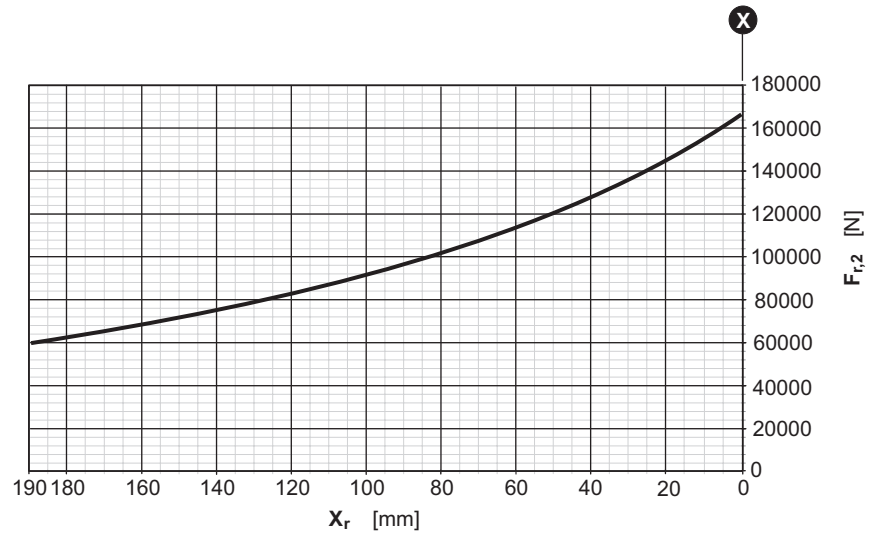
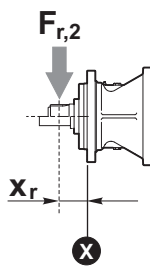

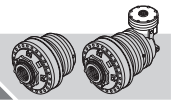

RR 810 .. SI

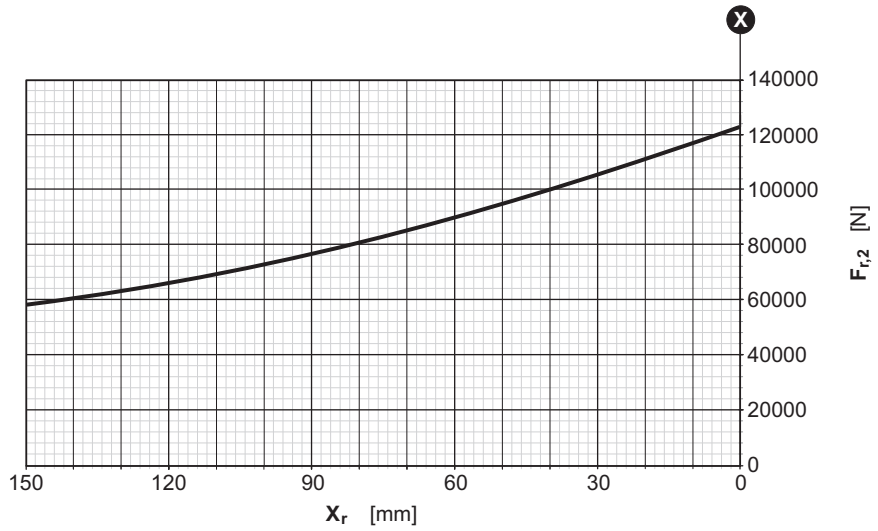
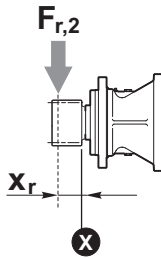

RR 810 .. VI
ZI

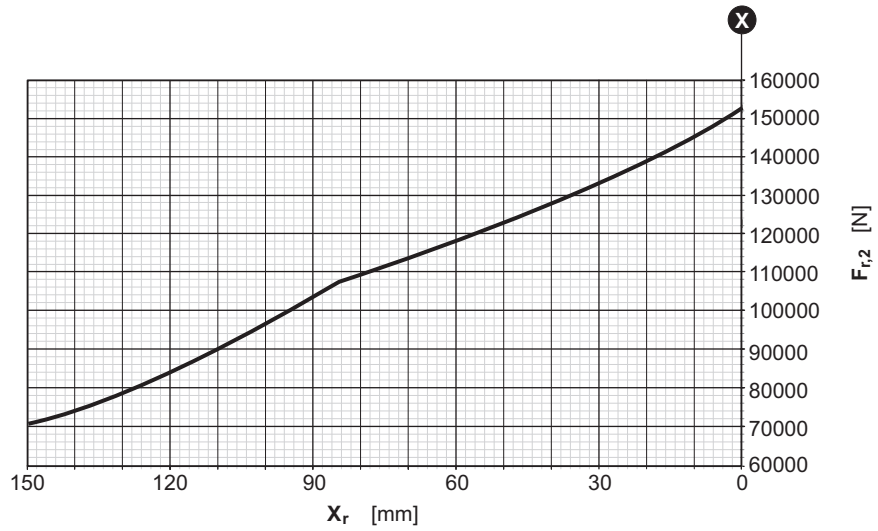
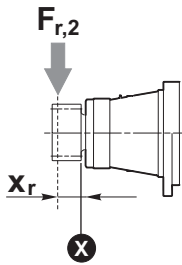

Fattore correttivo k_{r2} / k_{r2} Corrective coefficient / Korrekturfaktor k_{r2}
 Facteur correctif k_{r2} / Factor de corrección k_{r2} / Fator corretivo k_{r2}

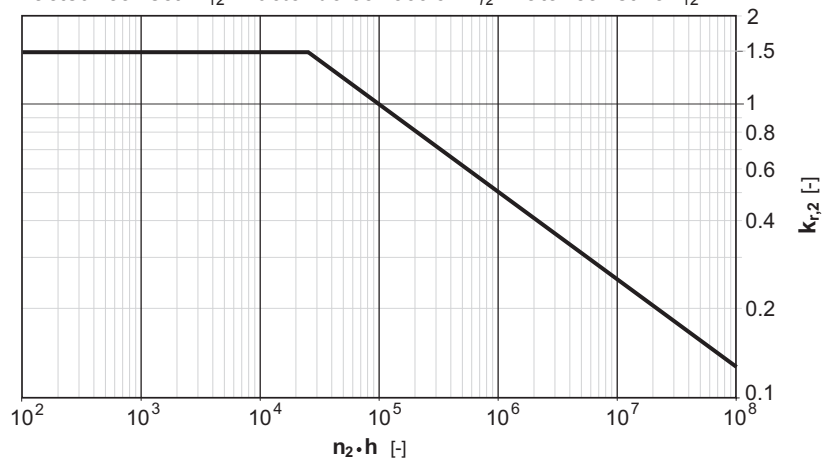



1010

IT EN DE FR ES PT

RR1010

..

i



| | i | T ₂ [Nm] | | | | | | n _{1max} [min ⁻¹] | T _{2max} [Nm] | P _t [kW] |
|----------------|----------------|-----------------------------|-----------------------------------|---------------------------------|------------------------------|----------------------------------|-------------------------------|---|---------------------------|------------------------|
| | | n ₂ x h | | | | | | | | |
| 1/... | | 10000 (10 ⁴) | 25000 (2.5 · 10 ⁴) | 50000 (5 · 10 ⁴) | 100000 (10 ⁵) | 500000 (5 · 10 ⁵) | 1000000 (10 ⁶) | | | |
| RR1010 | 4.00 | 17500 | 16310 | 15600 | 13870 | 10130 | 8230 | 2500 | 17500 | 39 |
| | 5.00 | 15970 | 13490 | 11880 | 10940 | 9870 | 8020 | | | |
| | 5.80 | 14680 | 12400 | 10920 | 10270 | 9310 | 7850 | | | |
| | 7.00 | 9980 | 8420 | 7470 | 7160 | 6490 | 6220 | | | |
| RR1010D | 13.60 | 17500 | 16310 | 15600 | 13870 | 10130 | 8230 | 3500 | 17500 | 23 |
| | 16.00 | 17500 | 16310 | 15600 | 13870 | 10130 | 8230 | | | |
| | 20.00 | 16090 | 14190 | 13590 | 13030 | 10130 | 8230 | | | |
| | 23.20 | 14160 | 12780 | 12240 | 11740 | 10130 | 8230 | | | |
| | 29.00 | 15970 | 13490 | 11880 | 10940 | 9870 | 8020 | | | |
| | 35.00 | 13250 | 12520 | 11880 | 10940 | 9870 | 8020 | | | |
| | 40.60 | 14680 | 12400 | 10920 | 10270 | 9310 | 7850 | | | |
| | 49.00 | 9980 | 8420 | 7470 | 7160 | 6490 | 6220 | | | |
| RR1010T | 64.00 | 17500 | 16310 | 15600 | 13870 | 10130 | 8230 | 3500 | 17500 | 17 |
| | 80.00 | 17500 | 16310 | 15600 | 13870 | 10130 | 8230 | | | |
| | 92.80 | 17500 | 16310 | 15600 | 13870 | 10130 | 8230 | | | |
| | 116.00 | 16090 | 14190 | 13590 | 13030 | 10130 | 8230 | | | |
| | 140.00 | 16090 | 14190 | 13590 | 13030 | 10130 | 8230 | | | |
| | 168.20 | 15970 | 13490 | 11880 | 10940 | 9870 | 8020 | | | |
| | 203.00 | 15970 | 13490 | 11880 | 10940 | 9870 | 8020 | | | |
| | 235.48 | 14680 | 12400 | 10920 | 10270 | 9310 | 7850 | | | |
| | 284.20 | 14680 | 12400 | 10920 | 10270 | 9310 | 7850 | | | |
| | 343.00 | 9980 | 8420 | 7470 | 7160 | 6490 | 6220 | | | |
| | RR1010Q | 380.48 | 17500 | 16310 | 15600 | 13870 | 10130 | | | |
| 475.60 | | 16090 | 14190 | 13590 | 13030 | 10130 | 8230 | | | |
| 576.00 | | 17500 | 16310 | 15600 | 13870 | 10130 | 8230 | | | |
| 668.16 | | 17500 | 16310 | 15600 | 13870 | 10130 | 8230 | | | |
| 835.20 | | 16090 | 14190 | 13590 | 13030 | 10130 | 8230 | | | |
| 1008.00 | | 16090 | 14190 | 13590 | 13030 | 10130 | 8230 | | | |
| 1211.04 | | 15970 | 13490 | 11880 | 10940 | 9870 | 8020 | | | |
| 1461.60 | | 15970 | 13490 | 11880 | 10940 | 9870 | 8020 | | | |
| 1695.46 | | 14680 | 12400 | 10920 | 10270 | 9310 | 7850 | | | |
| 2046.24 | | 14680 | 12400 | 10920 | 10270 | 9310 | 7850 | | | |
| 2469.60 | | 9980 | 8420 | 7470 | 7160 | 6490 | 6220 | | | |



RA1010

..

i



| i | T ₂ [Nm] | | | | | | n _{1max} [min ⁻¹] | T _{2max} [Nm] | P _t [kW] |
|-------|-----------------------------|-----------------------------------|---------------------------------|------------------------------|----------------------------------|-------------------------------|---|---------------------------|------------------------|
| | n ₂ x h | | | | | | | | |
| 1/... | 10000 (10 ⁴) | 25000 (2.5 · 10 ⁴) | 50000 (5 · 10 ⁴) | 100000 (10 ⁵) | 500000 (5 · 10 ⁵) | 1000000 (10 ⁶) | | | |

| | | | | | | | | | | |
|-------------------|----------------|-------|-------|-------|-------|-------|------|------|-------|----|
| RA1010 (A) | 16.00 | 6680 | 6050 | 5340 | 5080 | 3870 | 3140 | 3500 | 17500 | 33 |
| | 20.00 | 8310 | 7270 | 6550 | 6250 | 4520 | 3670 | | | |
| | 23.20 | 9610 | 8210 | 7520 | 7180 | 5020 | 4080 | | | |
| | 28.00 | 9980 | 8420 | 7470 | 7160 | 5720 | 4650 | | | |
| (B) | 10.91 | 17500 | 16310 | 15600 | 13870 | 10010 | 8130 | 2500 | 17500 | 41 |
| | 13.64 | 15970 | 13490 | 11880 | 10940 | 9870 | 8020 | | | |
| | 15.82 | 14680 | 12400 | 10920 | 10270 | 9310 | 7850 | | | |
| | 19.09 | 9980 | 8420 | 7470 | 7160 | 6490 | 6220 | | | |
| RA1010D | 54.40 | 17500 | 16310 | 15600 | 13870 | 8880 | 7220 | 3500 | 17500 | 24 |
| | 64.00 | 17500 | 16310 | 15600 | 13870 | 9950 | 8090 | | | |
| | 80.00 | 16090 | 14190 | 13590 | 13030 | 10130 | 8230 | | | |
| | 92.80 | 14160 | 12780 | 12240 | 11740 | 10130 | 8230 | | | |
| | 116.00 | 15970 | 13490 | 11880 | 10940 | 9870 | 8020 | | | |
| | 140.00 | 13250 | 12520 | 11880 | 10940 | 9870 | 8020 | | | |
| | 162.40 | 14680 | 12400 | 10920 | 10270 | 9310 | 7850 | | | |
| | 196.00 | 9980 | 8420 | 7470 | 7160 | 6490 | 6220 | | | |
| RA1010T | 206.08 | 17500 | 16310 | 15600 | 13870 | 9370 | 7610 | 3500 | 17500 | 17 |
| | 257.60 | 17500 | 16310 | 15600 | 13870 | 10130 | 8230 | | | |
| | 298.82 | 17500 | 16310 | 15600 | 13870 | 10130 | 8230 | | | |
| | 373.52 | 16090 | 14190 | 13590 | 13030 | 10130 | 8230 | | | |
| | 450.80 | 16090 | 14190 | 13590 | 13030 | 10130 | 8230 | | | |
| | 541.60 | 15970 | 13490 | 11880 | 10940 | 9870 | 8020 | | | |
| | 653.66 | 15970 | 13490 | 11880 | 10940 | 9870 | 8020 | | | |
| | 758.25 | 14680 | 12400 | 10920 | 10270 | 9310 | 7850 | | | |
| | 915.12 | 14680 | 12400 | 10920 | 10270 | 9310 | 7850 | | | |
| | 1104.46 | 9980 | 8420 | 7470 | 7160 | 6490 | 6220 | | | |
| | 1195.26 | 15970 | 13490 | 11880 | 10940 | 9870 | 8020 | | | |
| | 1386.51 | 14680 | 12400 | 10920 | 10270 | 9310 | 7850 | | | |
| | 1442.56 | 13250 | 12520 | 11880 | 10940 | 9870 | 8020 | | | |
| | 1673.37 | 14680 | 12400 | 10920 | 10270 | 9310 | 7850 | | | |
| 2019.58 | 9980 | 8420 | 7470 | 7160 | 6490 | 6220 | | | | |



RR1010 .. i ..

I

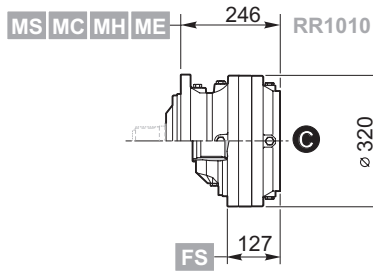

D

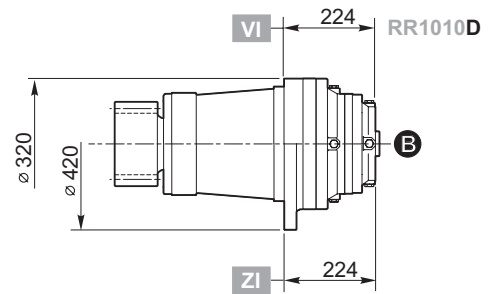
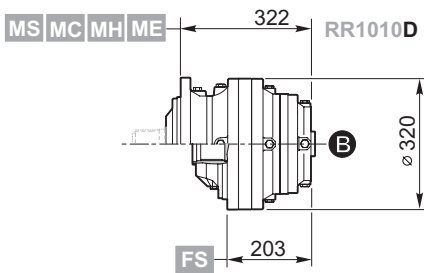

T

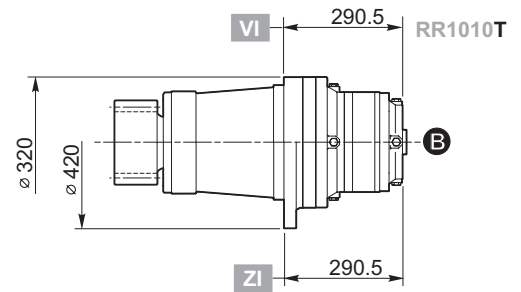
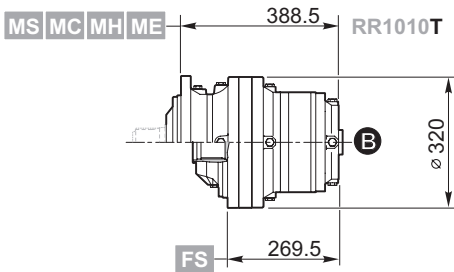

Q

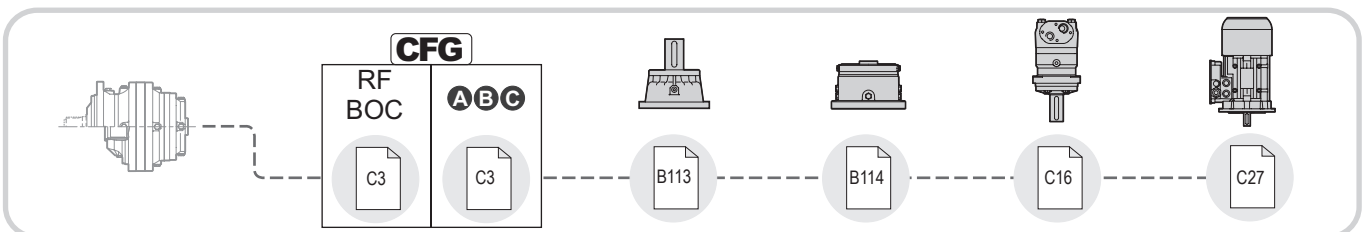
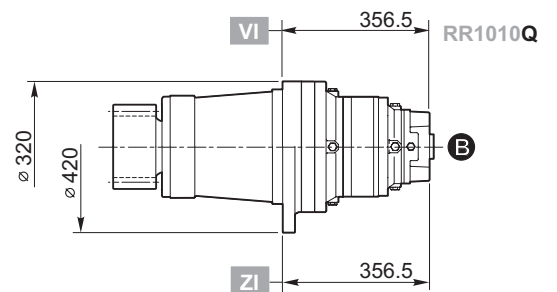
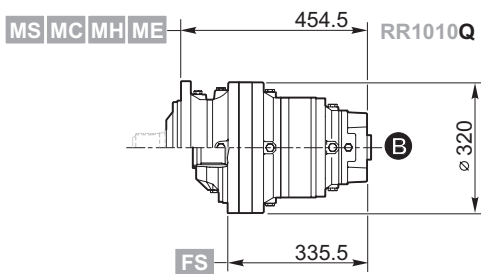

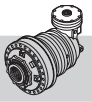

RA1010 .. i ..

I

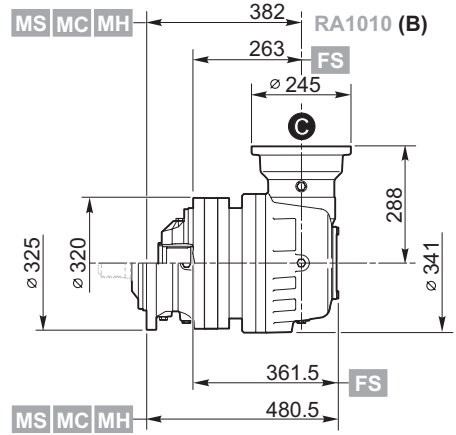
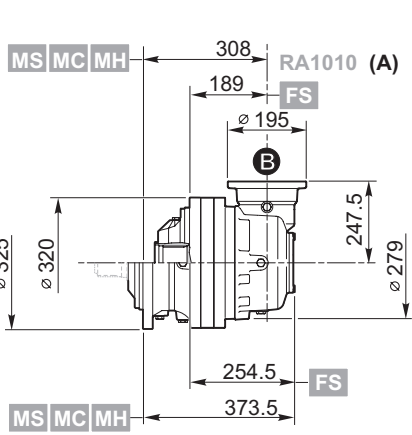

D

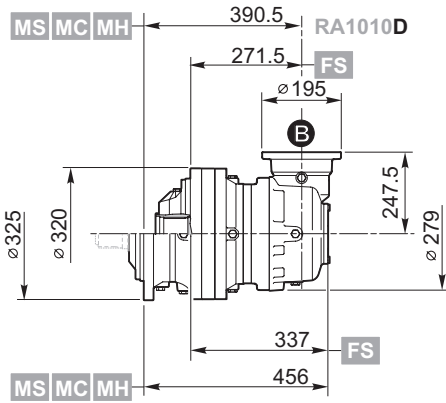

T

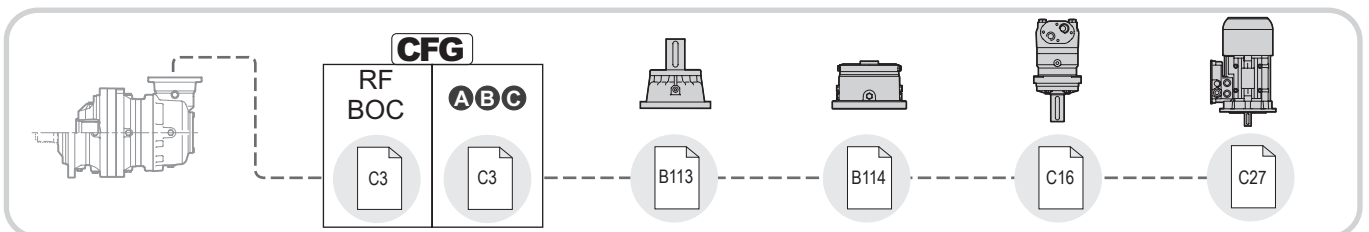
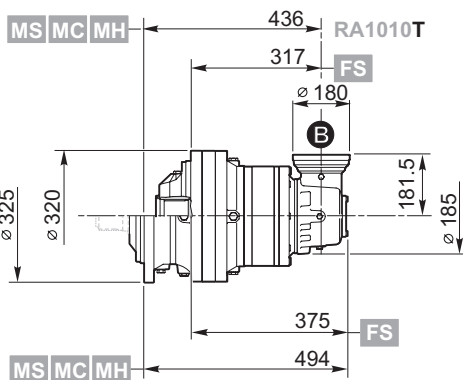

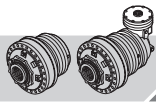

1010

IT EN DE FR ES PT

| | | | |
|--------|----|---|----|
| RR1010 | .. | i | .. |
| RA1010 | .. | | .. |

- MS
- MC
- MH
- ME

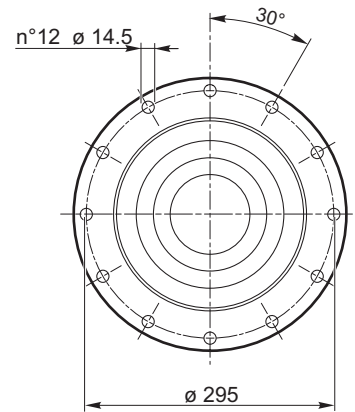
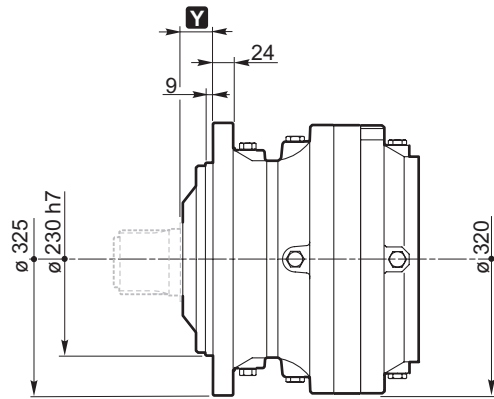

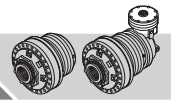

MS

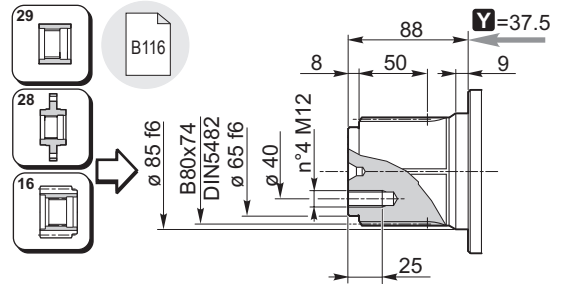
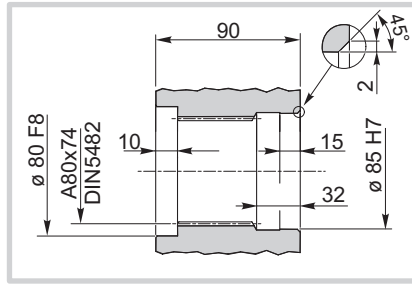
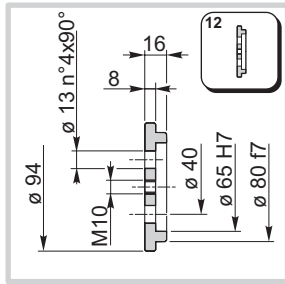

MC

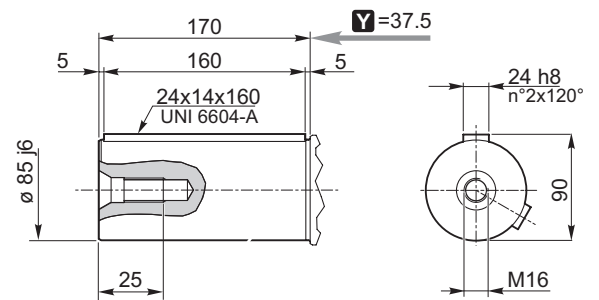
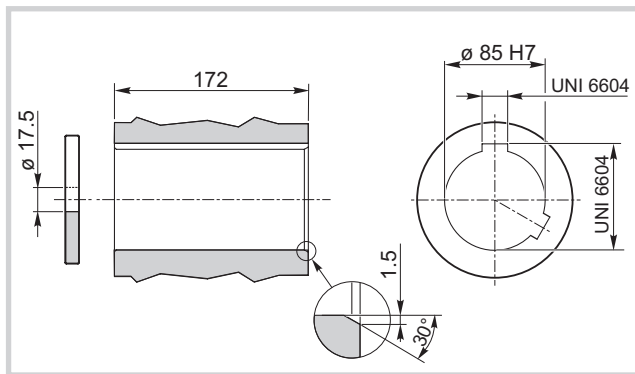

MH

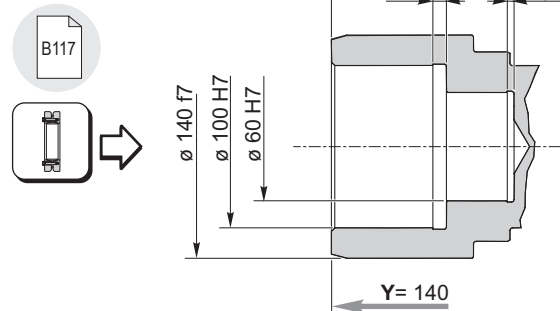
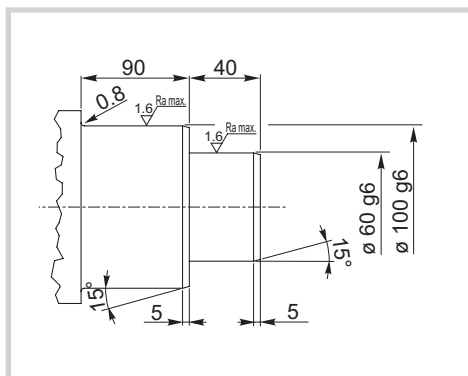

ME

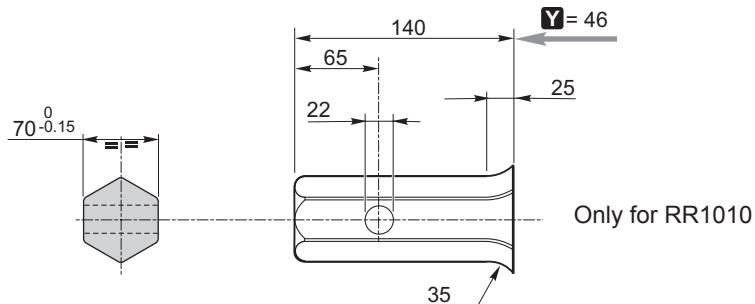

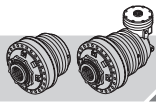

1010

IT EN DE FR ES PT

RR1010 .. i ..

VI

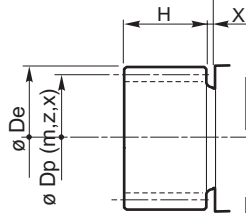
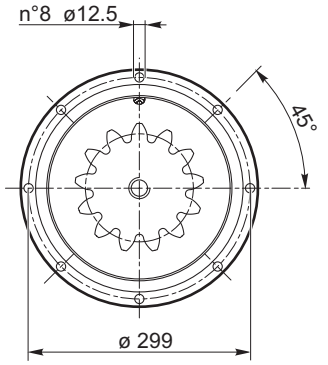
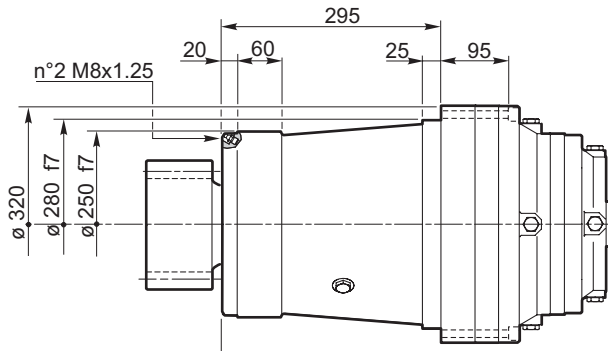

| m | z | x.m | H | Dp | De | X | code | |
|----|----|-----|-----|-----|-----|---|--------|----------|
| 8 | 16 | 0 | 80 | 128 | 144 | 5 | 03-333 | 154B3079 |
| 10 | 14 | +6 | 110 | 140 | 170 | 5 | 03-513 | 154F3001 |
| 10 | 15 | +5 | 95 | 150 | 180 | 5 | 03-316 | 154B2591 |
| 10 | 16 | +5 | 120 | 160 | 190 | 5 | 03-274 | 154-5636 |
| 12 | 11 | +6 | 95 | 132 | 166 | 5 | 03-401 | 154B7749 |
| 12 | 11 | +6 | 117 | 132 | 168 | 5 | 03-296 | 154-5756 |
| 12 | 14 | 0 | 90 | 168 | 192 | 5 | 03-283 | 154-5635 |

ZI

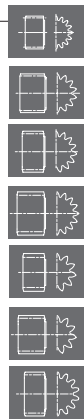
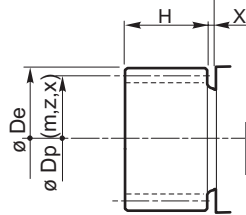
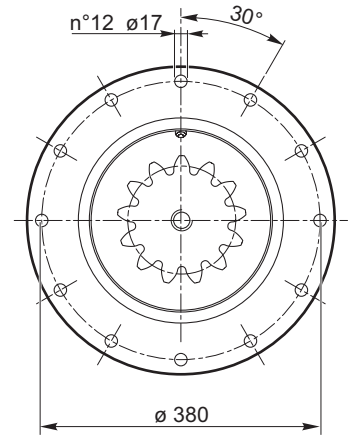
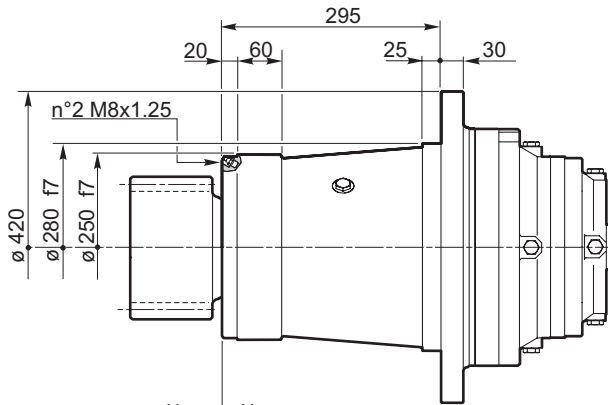

| m | z | x.m | H | Dp | De | X | code | |
|----|----|-----|-----|-----|-----|---|--------|----------|
| 8 | 16 | 0 | 80 | 128 | 144 | 5 | 03-333 | 154B3079 |
| 10 | 14 | +6 | 110 | 140 | 170 | 5 | 03-513 | 154F3001 |
| 10 | 15 | +5 | 95 | 150 | 180 | 5 | 03-316 | 154B2591 |
| 10 | 16 | +5 | 120 | 160 | 190 | 5 | 03-274 | 154-5636 |
| 12 | 11 | +6 | 95 | 132 | 166 | 5 | 03-401 | 154B7749 |
| 12 | 11 | +6 | 117 | 132 | 168 | 5 | 03-296 | 154-5756 |
| 12 | 14 | 0 | 90 | 168 | 192 | 5 | 03-283 | 154-5635 |

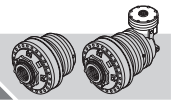

RR1010
RA1010 .. i **FS**

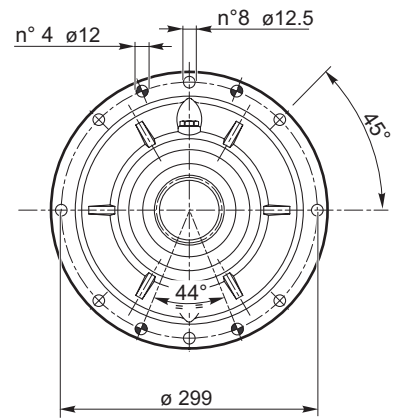
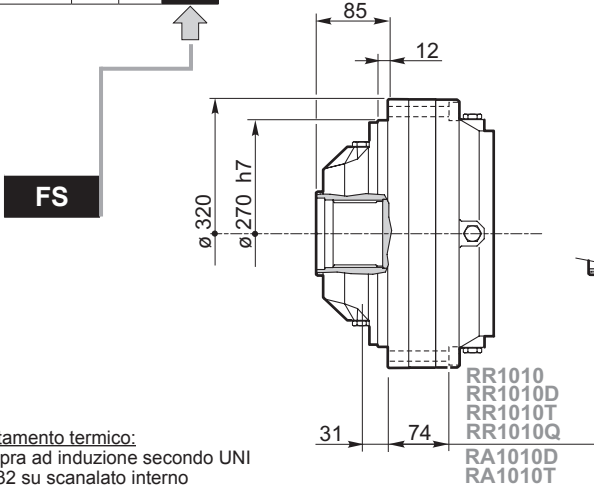

Treatmento termico:
Tempra ad induzione secondo UNI 10932 su scanalato interno

Heat treatment:
Induction hardening according to UNI 10932 on internal spline

Wärmebehandlung:
Induktionshärtung nach UNI 10932 an interner Nut

Traitement thermique:
Trempa par induction conformément à la norme UNI 10932 sur cannelé interne

Tratamiento térmico:
Temple por inducción según UNI 10932 en acanalado interno

Tratamento térmico:
Tempera por indução segundo UNI 10932 sobre ranhuras internas

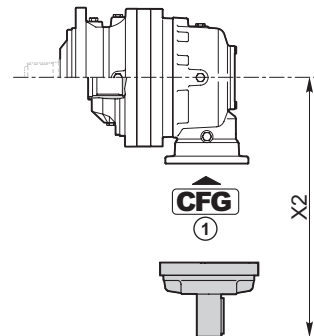
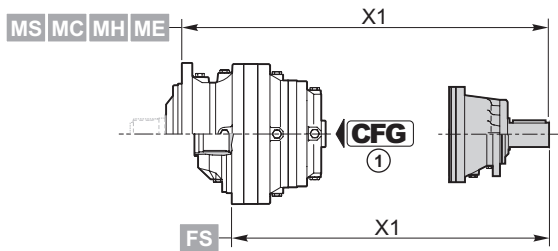
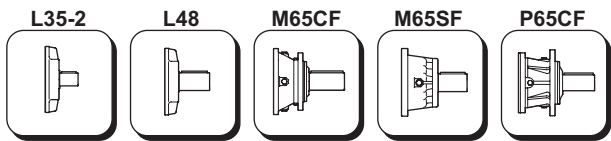
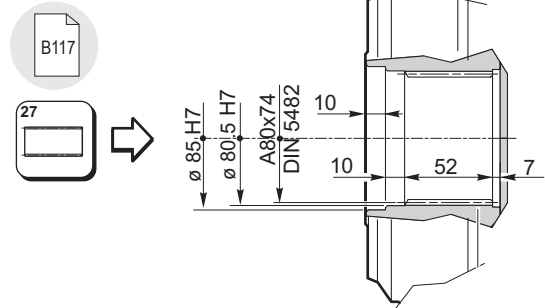
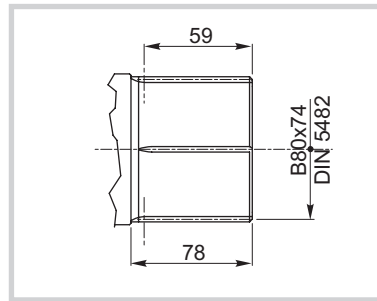

| | CFG ① | | code | X1 |
|---------|-------|-------|------------|----------------------------|
| RR1010 | — | P65CF | 154-2404 | 558 (M...) 439 (FS) |
| RR1010D | RF | M65SF | 154B4249 | 506.5 (M...) 387.5 (FS) |
| | RF | M65CF | 154-2407 | 529.5 (M...) 410.5 (FS) |
| | BOC | L48 | 154B3989 | 443.5 (M...) 324.5 (FS) |
| RR1010T | RF | M65SF | 154B4249 | 573 (M...) 454 (FS) |
| | RF | M65CF | 154-2407 | 596 (M...) 477 (FS) |
| RR1010Q | BOC | L48 | 154B3989 | 510 (M...) 391 (FS) |
| | BOC | L35-2 | 154-2190M1 | 544 (M...) 425 (FS) |

| | CFG ① | | code | X2 |
|------------|-------|-------|------------|-------|
| RA1010 (A) | BOC | L48 | 154B3989 | 347.5 |
| RA1010 (B) | - | P65CF | 154-2404 | 600 |
| RA1010D | BOC | L48 | 154B3989 | 347.5 |
| RA1010T | BOC | L35-2 | 154-2190M1 | 270.5 |

| CFG | |
|-------------|----|
| RF BOC | C3 |
| A B C | C3 |



1010

IT EN DE FR ES PT

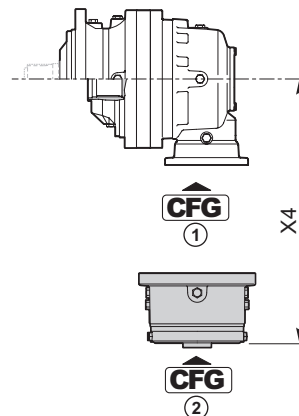
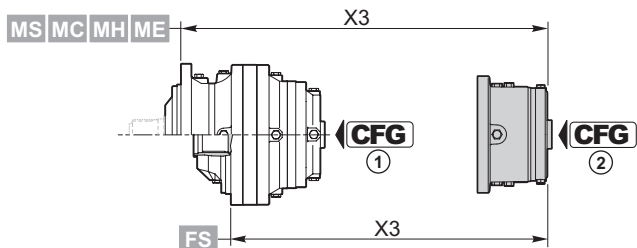
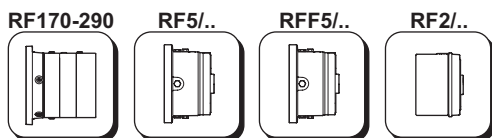

| RF170÷290 | CFG ① | T _f [Nm] | CFG ② | | |
|------------|-------|---------------------|------------|------------------------|-----|
| | | | C | | |
| | | | code | X3 | X4 |
| RR1010 | RF | 1700 | 154B9766M1 | 443 (M...) 324 (FS) | — |
| | | 2000 | 154B9767M1 | | |
| | | 2300 | 154B9768M1 | | |
| | | 2900 | 154B9769M1 | | |
| RA1010 (B) | - | 1700 | 154B9766M3 | — | 485 |
| | | 2000 | 154B9767M3 | | |
| | | 2300 | 154B9768M3 | | |
| | | 2900 | 154B9769M3 | | |

| RF5/.. | CFG ① | T _f [Nm] | CFG ② | | | | | | |
|---------|-------|---------------------|----------|----------------------------|----|-------------------|-------------------|----------------------------|----|
| | | | B | | | OMTS 12/24 z16 | OMVS 10/20 z16 | | |
| | | | code | X3 | X4 | code | code | X3 | X4 |
| RR1010D | RF | 210 | 154-2872 | 412.5 (M...) 293.5 (FS) | — | 154-2879 | 154-2886 | 416 (M...) 297 (FS) | — |
| | | 290 | 154-2873 | | | 154-2880 | 154-2887 | | |
| | | 430 | 154-2874 | | | 154-2881 | 154-2888 | | |
| | | 650 | 154-2875 | | | 154-2882 | 154-2889 | | |
| | | 850 | 154-2876 | | | 154-2883 | 154-2890 | | |
| | | 1100 | 154-2877 | | | 154-2884 | 154-2891 | | |
| | | 1300 | 154-2878 | | | 154-2885 | 154-2892 | | |
| RR1010T | RF | 210 | 154-2872 | 479 (M...) 360 (FS) | — | 154-2879 | 154-2886 | 482.7 (M...) 363.7 (FS) | — |
| | | 290 | 154-2873 | | | 154-2880 | 154-2887 | | |
| | | 430 | 154-2874 | | | 154-2881 | 154-2888 | | |
| | | 650 | 154-2875 | | | 154-2882 | 154-2889 | | |
| | | 850 | 154-2876 | | | 154-2883 | 154-2890 | | |
| | | 1100 | 154-2877 | | | 154-2884 | 154-2891 | | |
| | | 1300 | 154-2878 | | | 154-2885 | 154-2892 | | |

| RFF5/.. | CFG ① | T _f [Nm] | CFG ② | | | | | | |
|------------|-------|---------------------|----------|----|-------|-------------------|-------------------|----|-------|
| | | | B | | | OMTS 12/24 z16 | OMVS 10/20 z16 | | |
| | | | code | X3 | X4 | code | code | X3 | X4 |
| RA1010 (A) | RF | 210 | 154-2893 | — | 316.6 | 154-5338 | 154-5345 | — | 320.5 |
| | | 290 | 154-2894 | | | 154-5339 | 154-5346 | | |
| | | 430 | 154-2895 | | | 154-5340 | 154-5347 | | |
| | | 650 | 154-2896 | | | 154-5341 | 154-5348 | | |
| | | 850 | 154-2897 | | | 154-5342 | 154-5349 | | |
| | | 1100 | 154-2898 | | | 154-5343 | 154-5350 | | |
| | | 1300 | 154-2899 | | | 154-5344 | 154-5351 | | |
| RA1010D | RF | 210 | 154-2893 | — | 316.6 | 154-5338 | 154-5345 | — | 320.5 |
| | | 290 | 154-2894 | | | 154-5339 | 154-5346 | | |
| | | 430 | 154-2895 | | | 154-5340 | 154-5347 | | |
| | | 650 | 154-2896 | | | 154-5341 | 154-5348 | | |
| | | 850 | 154-2897 | | | 154-5342 | 154-5349 | | |
| | | 1100 | 154-2898 | | | 154-5343 | 154-5350 | | |
| | | 1300 | 154-2899 | | | 154-5344 | 154-5351 | | |



| RF2/.. | CFG ① | T _f [Nm] | CFG ② | | | | | | |
|---------|-------|------------------------|------------|----------------------------|-----------------------------|------------------------------|-----------------------------|------------------------------|----------------------------|
| | | | B | | OMP/OMR SAE A 2B Ø 25 | OMP/OMR SAE A 2B 1" 6B | OMP/OMR SAE A 4B Ø 25 | OMP/OMR SAE A 4B 1" 6B | X3 |
| | | | code | X3 | code | code | code | code | |
| RR1010D | RF | 70 | 154B9195 | 385 (M...) 266 (FS) | 154B9195M10 | - | 154B9195M16 | 154B9195M17 | 375 (M...) 256 (FS) |
| | | 140 | 154B9196 | | 154B9196M10 | - | 154B9196M16 | 154B9196M17 | |
| | | 210 | 154B9197 | | 154B9197M10 | - | 154B9197M16 | 154B9197M17 | |
| | | 320 | 154B9198 | | 154B9198M10 | - | 154B9198M16 | 154B9198M17 | |
| | | 430 | 154B9199 | | 154B9199M10 | - | 154B9199M16 | 154B9199M17 | |
| | | 600 | 154B9200 | | 154B9200M10 | - | 154B9200M16 | 154B9200M17 | |
| RR1010T | RF | 70 | 154-2345 | 451.5 (M...) 332.5 (FS) | 154-2345M10 | 154-2345M11 | 154-2345M16 | 154-2345M17 | 441.5 (M...) 322.5 (FS) |
| | | 140 | 154-2346 | | 154-2346M10 | 154-2346M11 | 154-2346M16 | 154-2346M17 | |
| | | 210 | 154-2347 | | 154-2347M10 | 154-2347M11 | 154-2347M16 | 154-2347M17 | |
| | | 320 | 154-2348 | | 154-2348M10 | 154-2348M11 | 154-2348M16 | 154-2348M17 | |
| | | 430 | 154-2349 | | 154-2349M10 | 154-2349M11 | 154-2349M16 | 154-2349M17 | |
| | | 600 | 154B9186 | | 154B9186M10 | 154B9186M11 | 154B9186M16 | 154B9186M17 | |
| RR1010Q | RF | 70 | 154-2838M1 | 493 (M...) 374 (FS) | 154-2863 | 154-2863M11 | 154-2635 | 154-2635M11 | 483 (M...) 364 (FS) |
| | | 140 | 154-2839M1 | | 154-2864 | 154-2864M11 | 154-2636 | 154-2636M11 | |
| | | 210 | 154-2840M1 | | 154-2865 | 154-2865M11 | 154-2637 | 154-2637M11 | |
| | | 320 | 154-2841M1 | | 154-2866 | 154-2866M11 | 154-2638 | 154-2638M11 | |
| | | 430 | 154-2842M1 | | 154-2867 | 154-2867M11 | 154-2639 | 154-2639M11 | |
| | | 600 | 154B8962M1 | | 154B9665 | 154B9665M11 | 154B9666 | 154B9666M11 | |

| | CFG ① | T _f [Nm] | CFG ② | | | | | | |
|------------|-------|------------------------|-------------|-------|-----------------------------|------------------------------|-----------------------------|------------------------------|-------|
| | | | B | | OMP/OMR SAE A 2B Ø 25 | OMP/OMR SAE A 2B 1" 6B | OMP/OMR SAE A 4B Ø 25 | OMP/OMR SAE A 4B 1" 6B | X4 |
| | | | code | X4 | code | code | code | code | |
| RA1010 (A) | RF | 70 | 154F2991 | 285.3 | | | | | — |
| | | 140 | 154F1890 | | | | | | |
| | | 210 | 154F2961 | | | | | | |
| | | 320 | 154B3591 | | | | | | |
| | | 430 | 154B3592 | | | | | | |
| | | 600 | 154F2992 | | | | | | |
| RA1010D | RF | 70 | 154F2991 | 285.3 | | | | | — |
| | | 140 | 154F1890 | | | | | | |
| | | 210 | 154F2961 | | | | | | |
| | | 320 | 154B3591 | | | | | | |
| | | 430 | 154B3592 | | | | | | |
| | | 600 | 154F2992 | | | | | | |
| RA1010T | RF | 70 | 154-2838M12 | 223.8 | 154-2863M12 | 154-2863M13 | 154-2635M12 | | 213.8 |
| | | 140 | 154-2839M12 | | 154-2864M12 | 154-2864M13 | 154-2636M12 | | |
| | | 210 | 154-2840M12 | | 154-2865M12 | 154-2865M13 | 154-2637M12 | | |
| | | 320 | 154-2841M12 | | 154-2866M12 | 154-2866M13 | 154-2638M12 | | |
| | | 430 | 154-2842M12 | | 154-2867M12 | 154-2867M13 | 154-2639M12 | | |
| | | 600 | 154B8962M12 | | 154B9665M12 | 154B9665M13 | 154B9666M12 | | |

CFG

RF
BOC 

A
B
C 

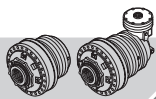

12

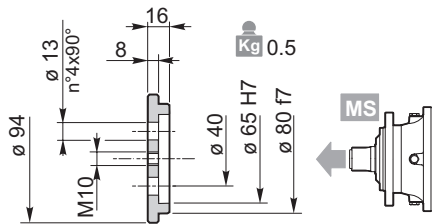

154-3062

Materiale / Material / Material / Matériau / Material / Material:
Acciaio / Steel / Stahl / Acier / Acero / Aço
C40 EN 10083-1 (1.1186)

28

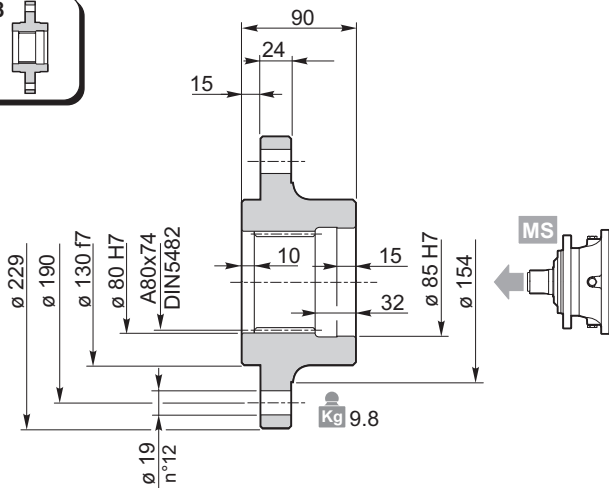

154-3359

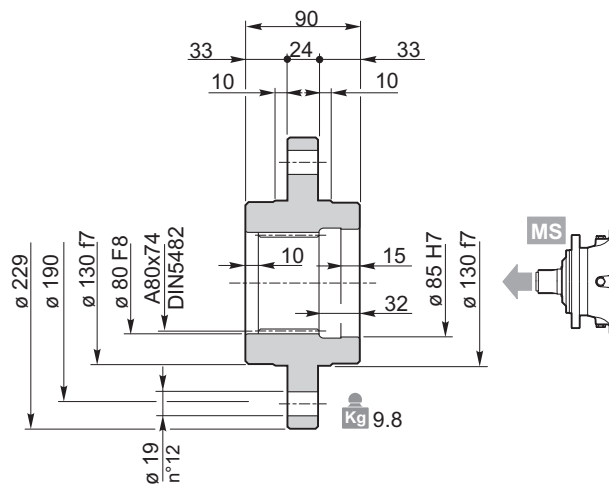

154-3112

Materiale / Material / Material / Matériau / Material / Material:
Acciaio / Steel / Stahl / Acier / Acero / Aço
EN 10083-1-C40 (1.1186)

Trattamento termico:
 Tempra ad induzione secondo UNI 10932 su scanalato interno

Heat treatment:
 Induction hardening according to UNI 10932 on internal spline

Wärmebehandlung:
 Induktionshärtung nach UNI 10932 an interner Nut

Traitement thermique :
 Trempe par induction conformément à la norme UNI 10932 sur cannelé interne

Tratamiento térmico:
 Temple por inducción según UNI 10932 en acanalado interno

Tratamento térmico:
 Tempera por indução segundo UNI 10932 sobre ranhuras internas

29

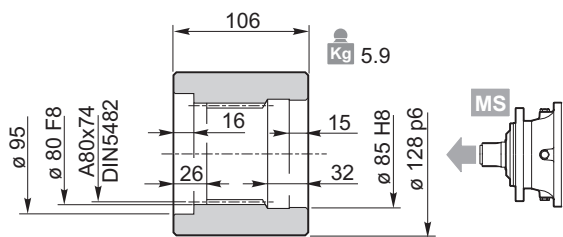

154-3093

Materiale / Material / Material / Matériau / Material / Material:
Acciaio / Steel / Stahl / Acier / Acero / Aço
39NiCrMo3 UNI 7845 (1.6511)

Trattamento termico:
 Tempra ad induzione secondo UNI 10932 su scanalato interno

Heat treatment:
 Induction hardening according to UNI 10932 on internal spline

Wärmebehandlung:
 Induktionshärtung nach UNI 10932 an interner Nut

Traitement thermique :
 Trempe par induction conformément à la norme UNI 10932 sur cannelé interne

Tratamiento térmico:
 Temple por inducción según UNI 10932 en acanalado interno

Tratamento térmico:
 Tempera por indução segundo UNI 10932 sobre ranhuras internas

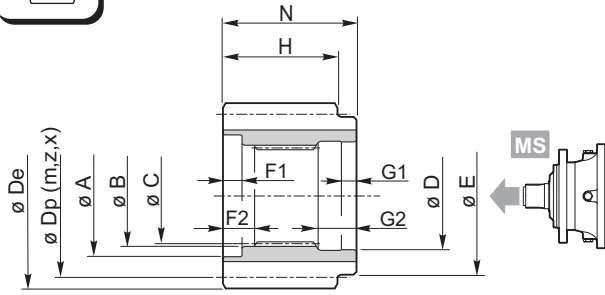
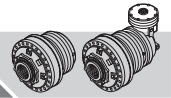

Materiale / Material / Material
 Matériau / Material / Material
 Acciaio / Steel / Stahl / Acier / Acero / Aço
 39NiCrMo3 UNI 7845 (1.6511)

Trattamento termico:
 Tempra ad induzione secondo UNI 10932 su scanalato interno

Heat treatment:
 Induction hardening according to UNI 10932 on internal spline

Wärmebehandlung:
 Induktionshärtung nach UNI 10932 an interner Nut

Traitement thermique :
 Trempe par induction conformément à la norme UNI 10932 sur cannelé interne

Tratamiento térmico:
 Temple por inducción según UNI 10932 en acanalado interno

Tratamento térmico:
 Tempera por indução segundo UNI 10932 sobre ranhuras internas

| | A | B | C | D | E | F1 | F2 | G1 | G2 | N | m | z | x | H | Dp | De | Code |
|----|----|-------|-------------------|-------|-----|----|----|----|----|-----|----|----|-------|----|-----|-------|----------|
| MS | 96 | 80 F8 | DIN5482 A80x74 | 85 H8 | 124 | 15 | 25 | 12 | 30 | 105 | 8 | 17 | 0.5 | 90 | 136 | 159 | 154-3071 |
| | 96 | 80 F8 | DIN5482 A80x74 | 85 H8 | 124 | 15 | 25 | 12 | 30 | 105 | 10 | 12 | 0.425 | 90 | 120 | 146 | 154-3081 |
| | 96 | 80 F8 | DIN5482 A80x74 | 85 H8 | 105 | 15 | 25 | 12 | 30 | 105 | 10 | 12 | 0.5 | 90 | 120 | 148 | 154B3834 |
| | 96 | 80 F8 | DIN5482 A80x74 | 85 H8 | 124 | 15 | 25 | 12 | 30 | 105 | 10 | 15 | 0 | 90 | 150 | 169 | 154-3069 |
| | 96 | 80 F8 | DIN5482 A80x74 | 85 H8 | 124 | 15 | 25 | 12 | 30 | 105 | 10 | 18 | 0 | 90 | 180 | 198.5 | 154-3044 |
| | 96 | 80 F8 | DIN5482 A80x74 | 85 H8 | 130 | 15 | 25 | 12 | 30 | 105 | 12 | 14 | 0.25 | 90 | 168 | 194.5 | 154-3080 |

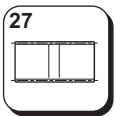

Kg 6.5

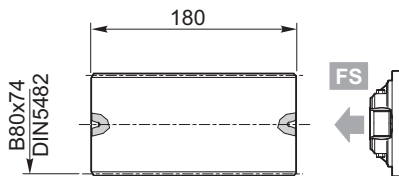

154-3054

Materiale / Material / Material
 Matériau / Material / Material:
 Acciaio / Steel / Stahl / Acier / Acero / Aço
 39NiCrMo3 UNI 7845 (1.6511)

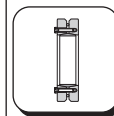

Kg 10

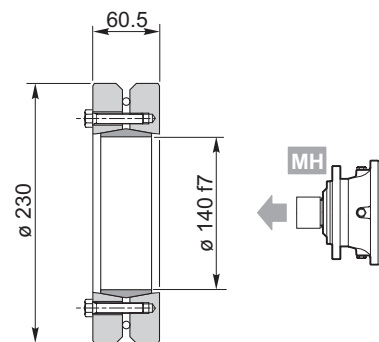

154F3778

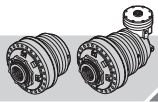

1010

IT EN DE FR ES PT

| | | | |
|----|------|----|-----------|
| RR | 1010 | .. | MS |
| RA | | | MC |
| | | | ME |

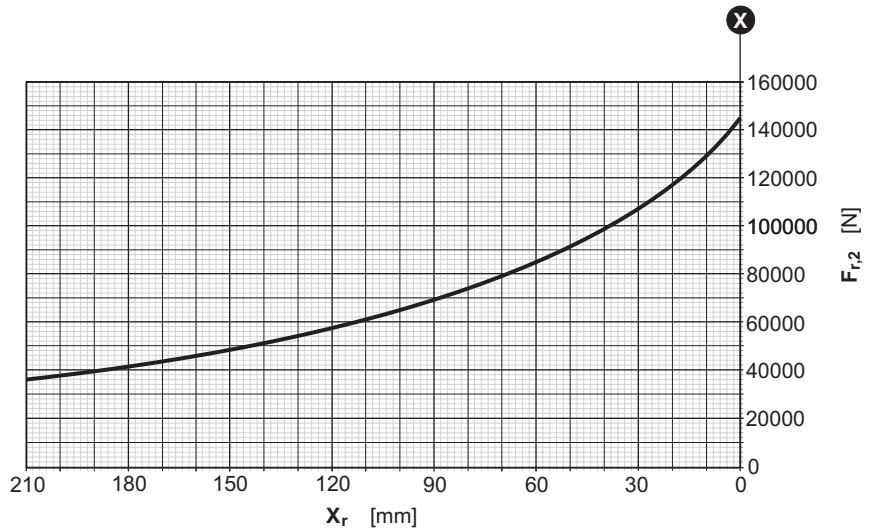
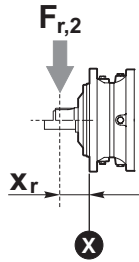

| | | | |
|----|------|----|-----------|
| RR | 1010 | .. | VI |
| | | | ZI |

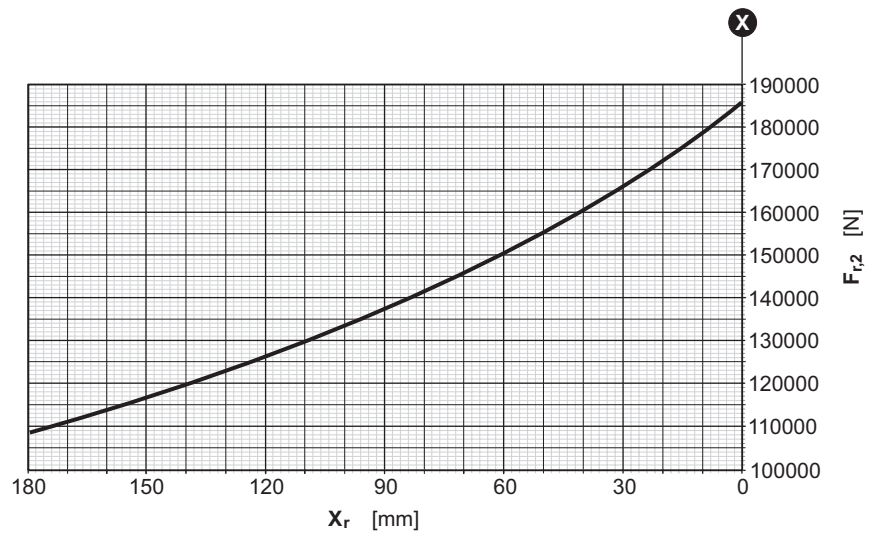
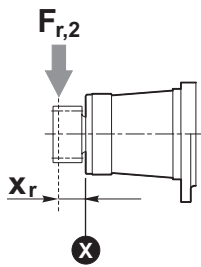

Fattore correttivo k_{r2} / k_{r2} Corrective coefficient / Korrekturfaktor k_{r2}
 Facteur correctif k_{r2} / Factor de corrección k_{r2} / Fator corretivo k_{r2}

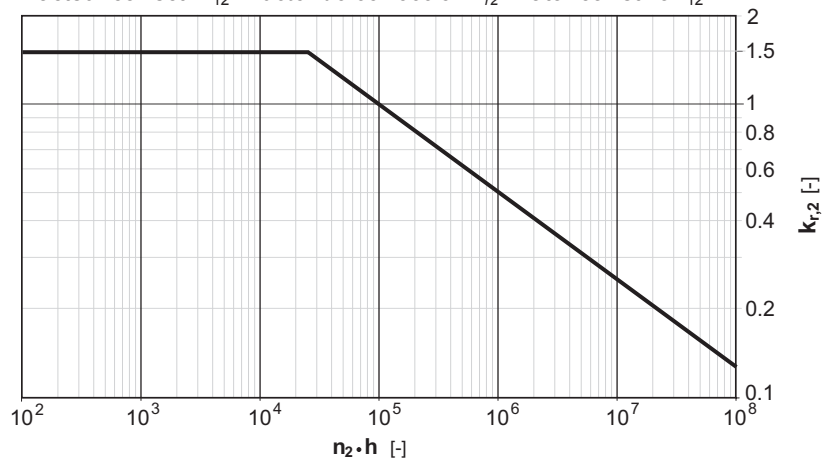

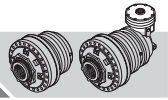



1700

IT EN DE FR ES PT

RR1700

..

i



| | i 1/... | T ₂ [Nm] | | | | | | n _{1max} [min ⁻¹] | T _{2max} [Nm] | P _t [kW] |
|----------------|----------------|-----------------------------|-----------------------------------|---------------------------------|------------------------------|----------------------------------|-------------------------------|---|---------------------------|------------------------|
| | | n ₂ x h | | | | | | | | |
| | | 10000 (10 ⁴) | 25000 (2.5 · 10 ⁴) | 50000 (5 · 10 ⁴) | 100000 (10 ⁵) | 500000 (5 · 10 ⁵) | 1000000 (10 ⁶) | | | |
| RR1700 | 3.90 | 25000 | 23550 | 21350 | 18700 | 13740 | 11160 | 2000 | 26500 | 48 |
| | 4.41 | 22700 | 21390 | 20470 | 18340 | 13470 | 10940 | | | |
| | 5.14 | 19910 | 16560 | 14410 | 13250 | 12010 | 10800 | | | |
| | 6.27 | 16730 | 13910 | 12100 | 11510 | 10430 | 9990 | | | |
| RR1700D | 13.26 | 20320 | 19620 | 18760 | 17220 | 10630 | 8630 | 3500 | 26500 | 28 |
| | 15.60 | 21370 | 18120 | 17370 | 16650 | 11840 | 9620 | | | |
| | 17.64 | 22700 | 20350 | 19500 | 18340 | 12910 | 10490 | | | |
| | 22.05 | 17420 | 15550 | 14900 | 14280 | 12590 | 10230 | | | |
| | 25.08 | 16730 | 13910 | 12100 | 11510 | 10430 | 9990 | | | |
| | 31.35 | 16730 | 13910 | 12100 | 11510 | 10430 | 9990 | | | |
| | 43.89 | 16390 | 13910 | 12100 | 11510 | 10430 | 9990 | | | |
| RR1700T | 53.04 | 20320 | 19620 | 18760 | 17220 | 10630 | 8630 | 3500 | 26500 | 21 |
| | 62.40 | 21370 | 18120 | 17370 | 16650 | 11840 | 9620 | | | |
| | 78.00 | 21370 | 18120 | 17370 | 16650 | 11840 | 9620 | | | |
| | 90.48 | 21370 | 18120 | 17370 | 16650 | 11840 | 9620 | | | |
| | 109.20 | 20770 | 18120 | 17370 | 16650 | 11840 | 9620 | | | |
| | 136.50 | 15760 | 13850 | 13270 | 12720 | 11520 | 9380 | | | |
| | 175.56 | 16730 | 13910 | 12100 | 11510 | 10430 | 9990 | | | |
| | 219.45 | 16730 | 13910 | 12100 | 11510 | 10430 | 9990 | | | |
| | 254.56 | 16730 | 13910 | 12100 | 11510 | 10430 | 9990 | | | |
| | 307.23 | 16390 | 13910 | 12100 | 11510 | 10430 | 9990 | | | |
| | RR1700Q | 370.97 | 21370 | 18120 | 17370 | 16650 | 11840 | | | |
| 449.28 | | 21370 | 18120 | 17370 | 16650 | 11840 | 9620 | | | |
| 561.60 | | 21370 | 18120 | 17370 | 16650 | 11840 | 9620 | | | |
| 651.46 | | 21370 | 18120 | 17370 | 16650 | 11840 | 9620 | | | |
| 786.24 | | 20770 | 18120 | 17370 | 16650 | 11840 | 9620 | | | |
| 814.32 | | 15760 | 13850 | 13270 | 12720 | 11520 | 9380 | | | |
| 889.06 | | 22700 | 20350 | 19500 | 18340 | 12910 | 10490 | | | |
| 982.80 | | 15760 | 13850 | 13270 | 12720 | 11520 | 9380 | | | |
| 1264.03 | | 16730 | 13910 | 12100 | 11510 | 10430 | 9990 | | | |
| 1580.04 | | 16730 | 13910 | 12100 | 11510 | 10430 | 9990 | | | |
| 1832.85 | | 16730 | 13910 | 12100 | 11510 | 10430 | 9990 | | | |
| 2212.06 | | 16390 | 13910 | 12100 | 11510 | 10430 | 9990 | | | |



RA1700

..

i



| i | T ₂ [Nm] | | | | | | n _{1max} [min ⁻¹] | T _{2max} [Nm] | P _t [kW] | |
|-------------------|-----------------------------|-----------------------------------|---------------------------------|------------------------------|----------------------------------|-------------------------------|---|---------------------------|------------------------|----|
| | n ₂ x h | | | | | | | | | |
| | 10000 (10 ⁴) | 25000 (2.5 · 10 ⁴) | 50000 (5 · 10 ⁴) | 100000 (10 ⁵) | 500000 (5 · 10 ⁵) | 1000000 (10 ⁶) | | | | |
| RA1700 (A) | 15.60 | 6510 | 5930 | 5230 | 4960 | 3800 | 3090 | 3500 | 26500 | 38 |
| | 17.64 | 7350 | 6560 | 5830 | 5560 | 4140 | 3370 | | | |
| | 20.56 | 8540 | 7440 | 6720 | 6420 | 4610 | 3750 | | | |
| | 25.08 | 10320 | 8750 | 8090 | 7720 | 5300 | 4310 | | | |
| (B) | 10.64 | 23860 | 22960 | 19630 | 15940 | 9840 | 7990 | 2500 | 26500 | 46 |
| | 12.03 | 22700 | 21390 | 20470 | 17380 | 10720 | 8710 | | | |
| | 14.02 | 19910 | 16560 | 14410 | 13250 | 11940 | 9700 | | | |
| | 17.10 | 16730 | 13910 | 12100 | 11510 | 10430 | 9990 | | | |
| RA1700D | 53.04 | 18590 | 16620 | 15850 | 14140 | 8730 | 7090 | 3500 | 26500 | 27 |
| | 62.40 | 21250 | 18120 | 17370 | 15850 | 9780 | 7940 | | | |
| | 70.56 | 22700 | 20350 | 19500 | 17280 | 10660 | 8660 | | | |
| | 88.20 | 17420 | 15550 | 14900 | 14280 | 12460 | 10120 | | | |
| | 100.32 | 16730 | 13910 | 12100 | 11510 | 10430 | 9990 | | | |
| | 125.40 | 16730 | 13910 | 12100 | 11510 | 10430 | 9990 | | | |
| | 175.56 | 16390 | 13910 | 12100 | 11510 | 10430 | 9990 | | | |
| RA1700T | 200.93 | 21370 | 18120 | 17370 | 14910 | 9200 | 7470 | 3500 | 26500 | 19 |
| | 251.16 | 21370 | 18120 | 17370 | 16650 | 10760 | 8740 | | | |
| | 291.35 | 21370 | 18120 | 17370 | 16650 | 11840 | 9620 | | | |
| | 351.62 | 20770 | 18120 | 17370 | 16650 | 11840 | 9620 | | | |
| | 439.53 | 15760 | 13850 | 13270 | 12720 | 11520 | 9380 | | | |
| | 565.30 | 16730 | 13910 | 12100 | 11510 | 10430 | 9990 | | | |
| | 706.63 | 16730 | 13910 | 12100 | 11510 | 10430 | 9990 | | | |
| | 819.69 | 16730 | 13910 | 12100 | 11510 | 10430 | 9990 | | | |
| | 989.28 | 16390 | 13910 | 12100 | 11510 | 10430 | 9990 | | | |
| | 1054.22 | 15330 | 14010 | 13420 | 12870 | 11660 | 10000 | | | |
| | 1125.20 | 10720 | 9920 | 9500 | 9110 | 8250 | 7910 | | | |
| | 1272.34 | 11850 | 11130 | 10670 | 10230 | 9260 | 8880 | | | |
| | 1482.95 | 13600 | 12860 | 12320 | 11810 | 10700 | 10250 | | | |
| | 1808.97 | 16390 | 13910 | 12100 | 11510 | 10430 | 9990 | | | |



1700

IT EN DE FR ES PT

RR1700 .. i ..

MS MC MH 170 RR1700

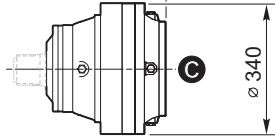

BS BC 272.5 RR1700
BH BE

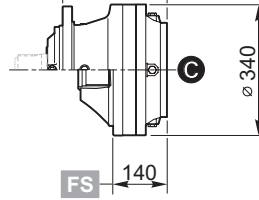

MS MC MH 246 RR1700D

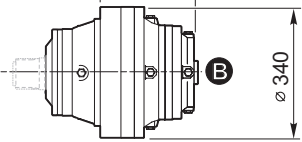

BS BC 348.5 RR1700D
BH BE

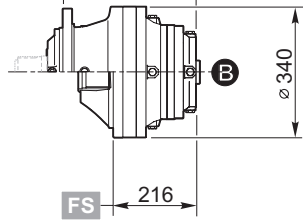

VI 242 RR1700D

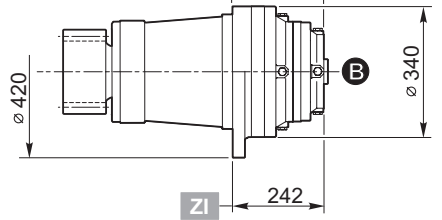

MS MC MH 312.5 RR1700T

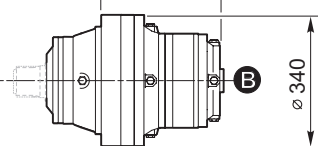

BS BC 415 RR1700T
BH BE

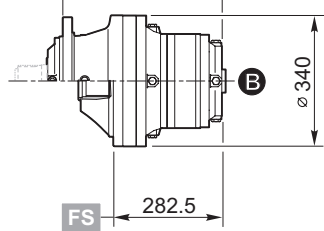

VI 308.5 RR1700T

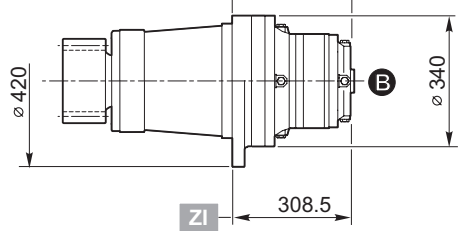

MS MC MH 378.5 RR1700Q

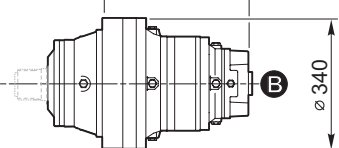

BS BC 481 RR1700Q
BH BE

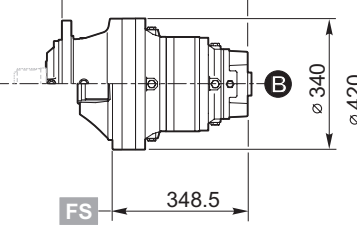

VI 374.5 RR1700Q

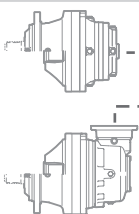
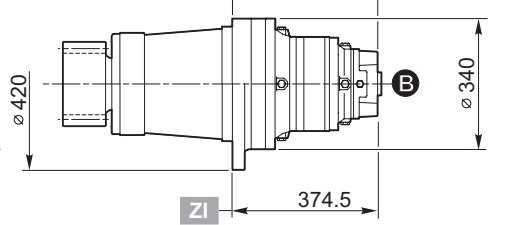

CFG

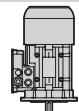
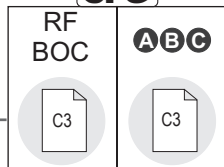

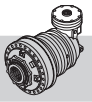

RA1700 .. i B.. FS

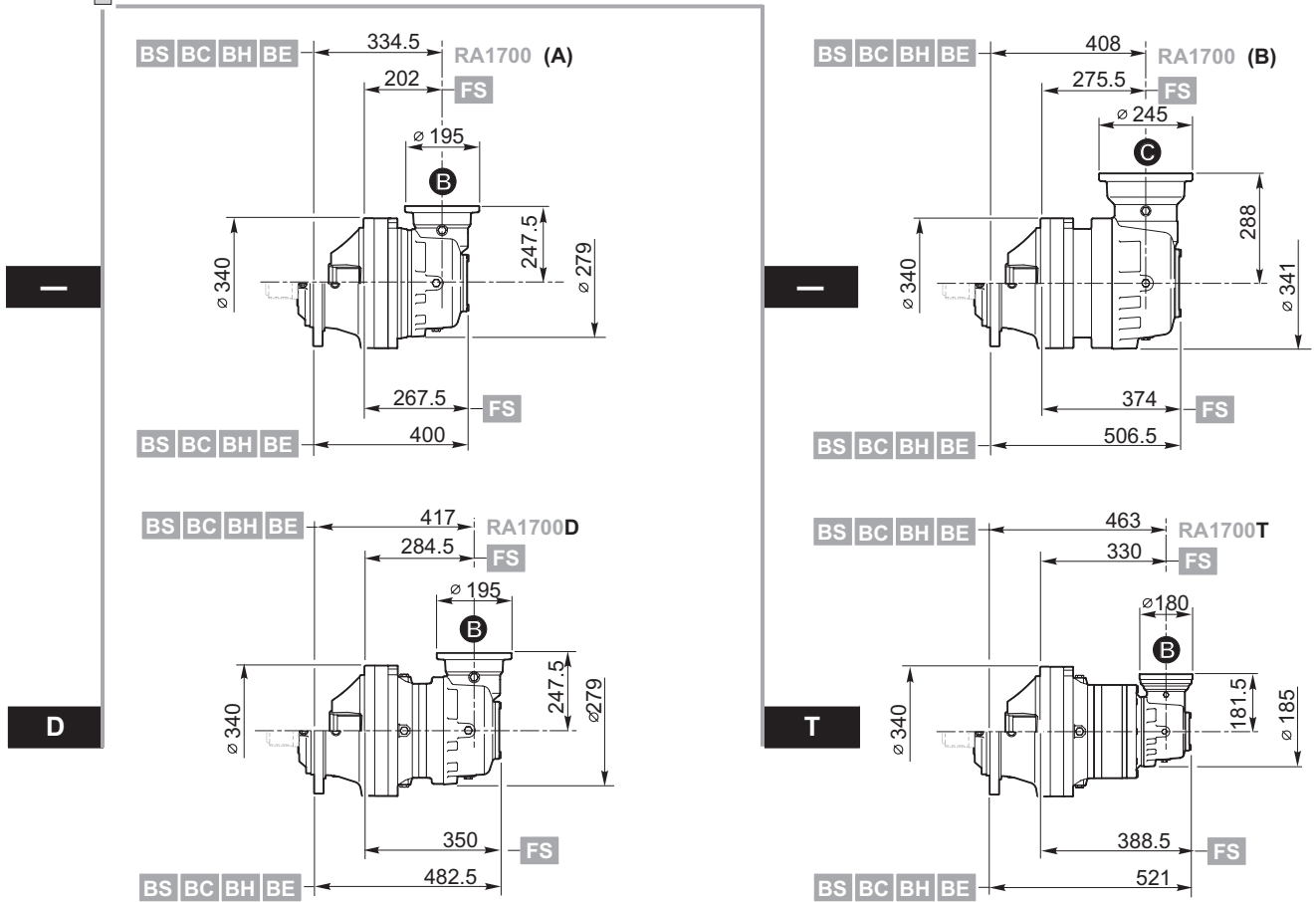

RA1700 .. i M

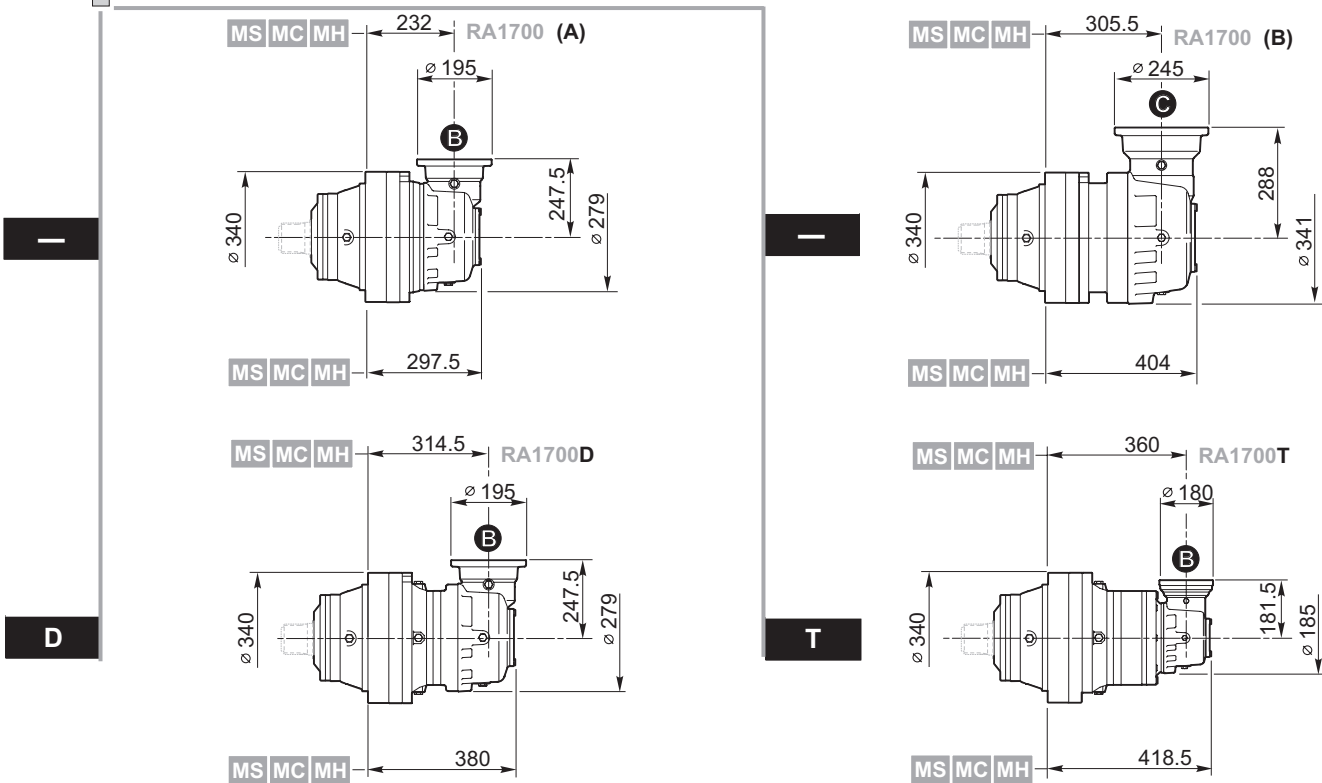

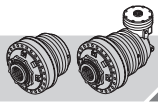

1700

IT EN DE FR ES PT

| | | | |
|--------|----|---|----|
| RR1700 | .. | i | .. |
| RA1700 | .. | | .. |

- MS
- MC
- MH

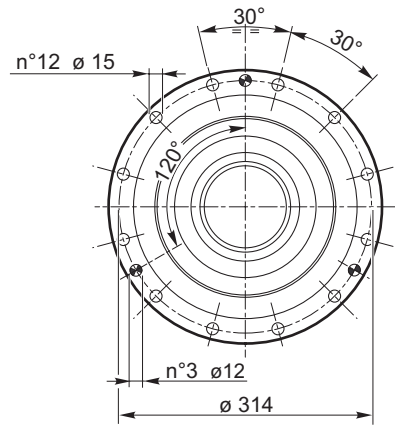
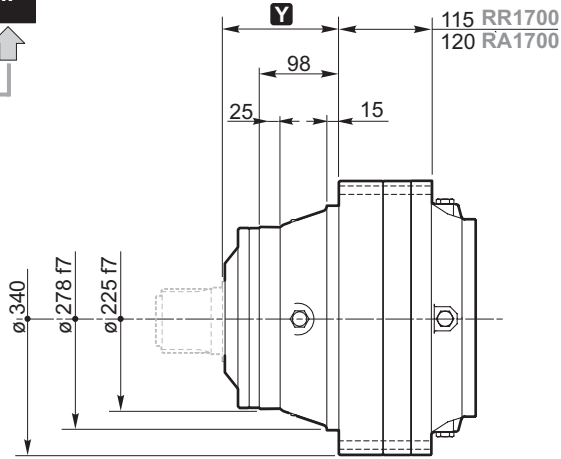

- BS
- BC
- BH
- BE

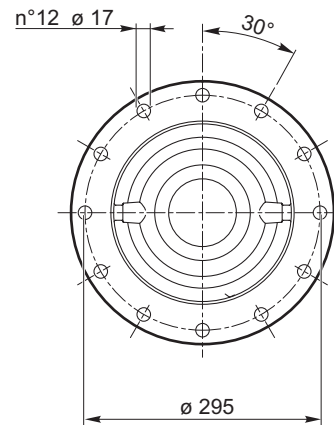
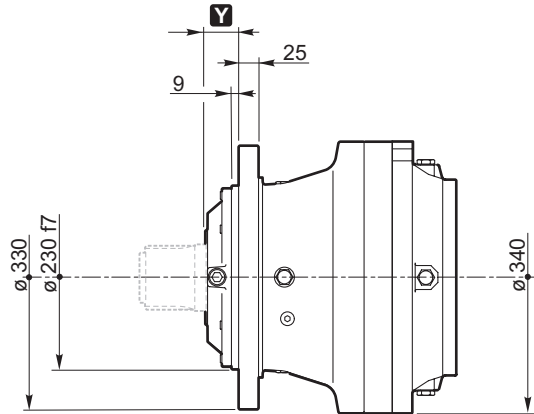

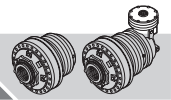

MS
BS

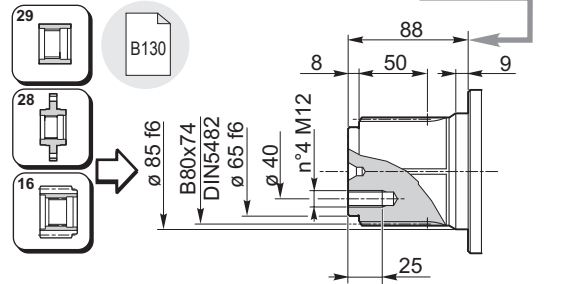
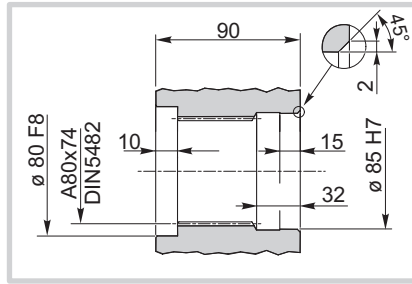
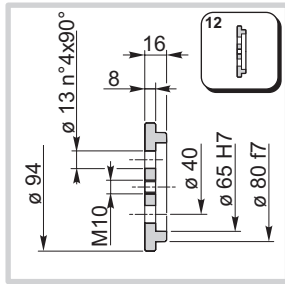

MC
BC

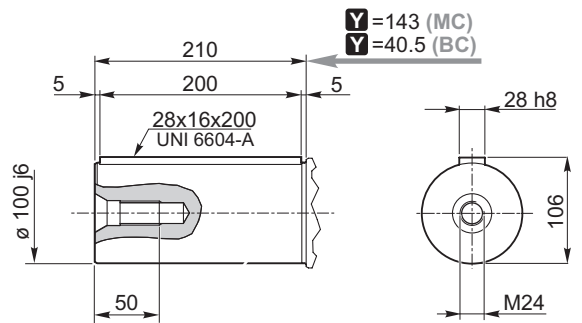
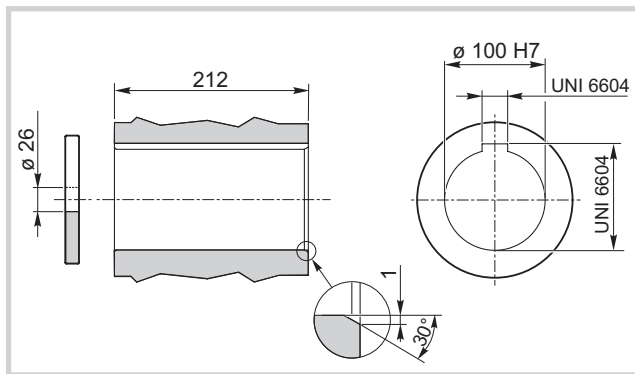

MH
BH

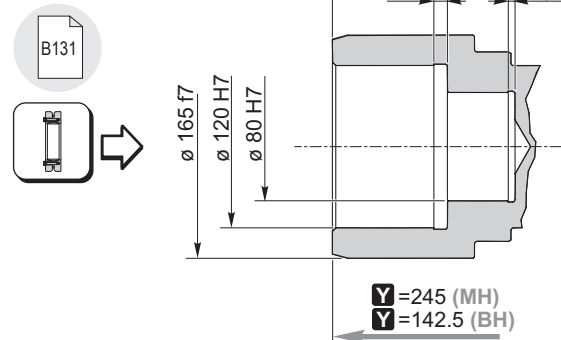
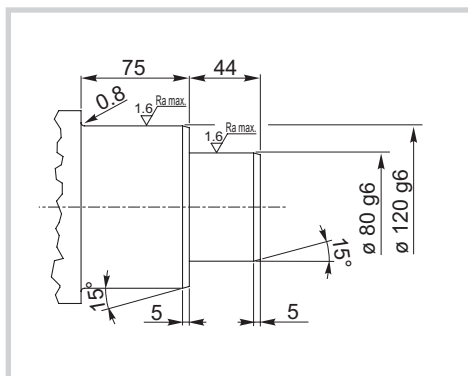

BE

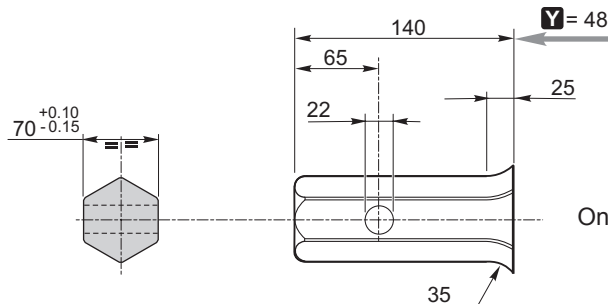

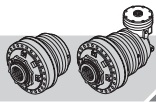

1700

IT EN DE FR ES PT

RR1700 .. i ..

VI

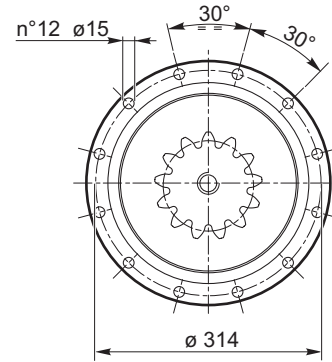
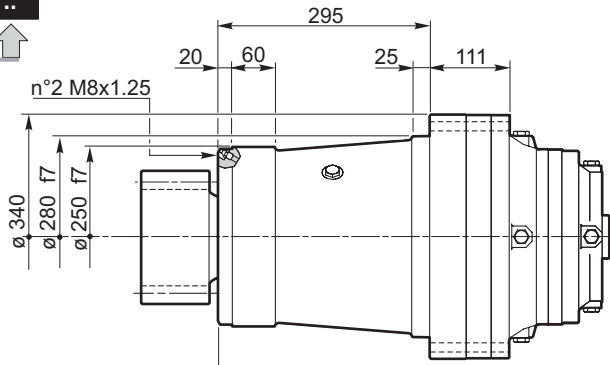

ZI

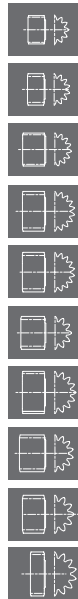
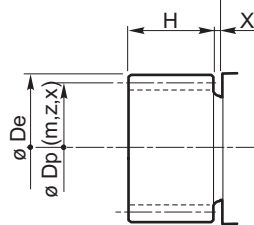
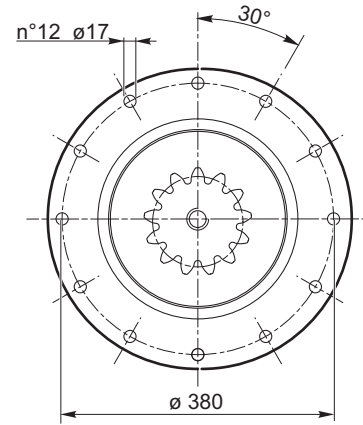
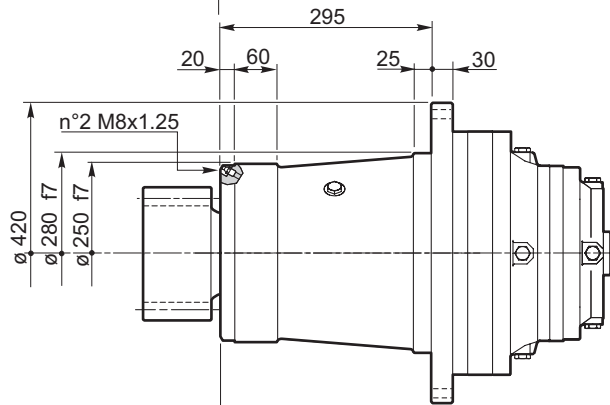

| m | z | x.m | H | Dp | De | X | code | |
|----|----|------|-----|-----|-----|---|--------|----------|
| 10 | 12 | 8 | 90 | 120 | 153 | 5 | 03-397 | 154B6334 |
| 10 | 14 | 5 | 90 | 140 | 170 | 5 | 03-403 | 154B8638 |
| 10 | 15 | 5 | 120 | 150 | 178 | 8 | 03-281 | 154-5632 |
| 10 | 18 | 8 | 120 | 180 | 215 | 5 | 03-334 | 154B3506 |
| 10 | 18 | 7.5 | 120 | 180 | 214 | 5 | 03-339 | 154B3578 |
| 12 | 12 | 6 | 130 | 144 | 178 | 5 | 03-451 | 154F0578 |
| 12 | 16 | 6 | 120 | 192 | 228 | 5 | 03-279 | 154-5633 |
| 12 | 14 | 3.78 | 137 | 168 | 199 | 5 | 03-531 | 154F3698 |
| 14 | 12 | 7 | 120 | 168 | 205 | 5 | 03-396 | 154B6995 |
| 14 | 14 | 7 | 75 | 196 | 238 | 5 | 03-309 | 154B2442 |

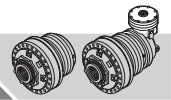

| | | | |
|--------|----|---|-----------|
| RR1700 | .. | i | FS |
| RA1700 | | | |

FS

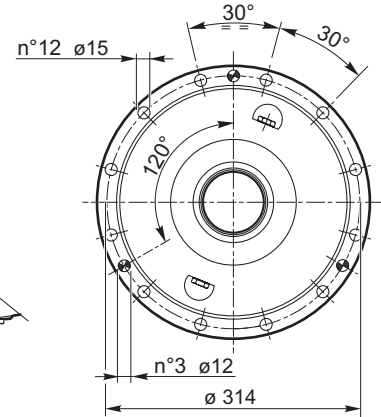
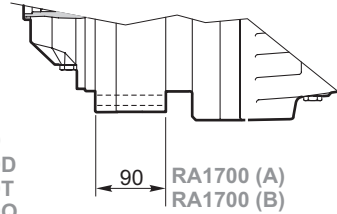
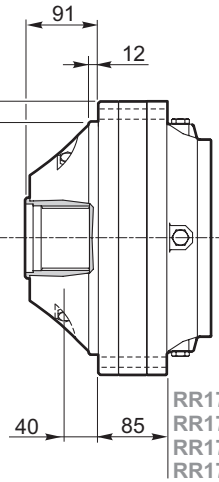

Trattamento termico:
Tempra ad induzione secondo UNI 10932 su scanalato interno

Heat treatment:
Induction hardening according to UNI 10932 on internal spline

Wärmebehandlung:
Induktionshärtung nach UNI 10932 an interner Nut

Traitement thermique :
Trempe par induction conformément à la norme UNI 10932 sur cannelé interne

Tratamiento térmico:
Temple por inducción según UNI 10932 en acanalado interno

Tratamento térmico:
Tempera por indução segundo UNI 10932 sobre ranhuras internas

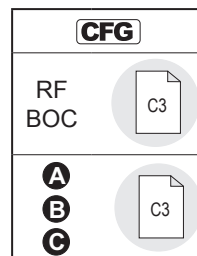
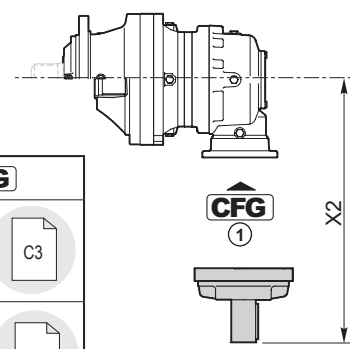
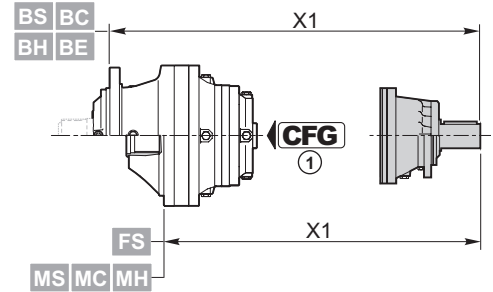
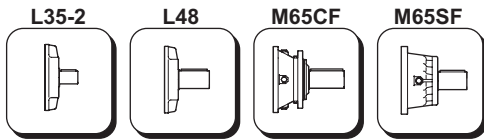
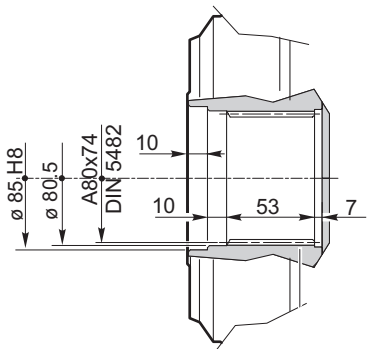
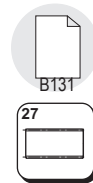
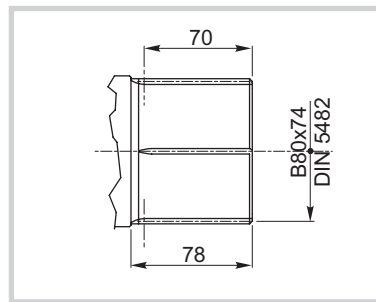

| | CFG ① | | code | X1 |
|----------------|-----------------|--------------|------------|--|
| RR1700 | - | P65CF | 154-2404 | 482 (M...) 452 (FS) 584.5 (B...) |
| RR1700D | RF | M65SF | 154B4249 | 430.5 (M...) 400.5 (FS) 533 (B...) |
| | RF | M65CF | 154-2407 | 453.5 (M...) 423.5 (FS) 556 (B...) |
| | BOC | L48 | 154B3989 | 367.5 (M...) 337.5 (FS) 470 (B...) |
| RR1700T | RF | M65SF | 154B4249 | 497 (M...) 467 (FS) 599.5 (B...) |
| | RF | M65CF | 154-2407 | 520 (M...) 490 (FS) 622.5 (B...) |
| | BOC | L48 | 154B3989 | 434 (M...) 404 (FS) 536.5 (B...) |
| RR1700Q | BOC | L35-2 | 154-2190M1 | 468 (M...) 438 (FS) 570.5 (B...) |

| | CFG ① | | code | X2 |
|-------------------|-----------------|--------------|------------|-------|
| RA1700 (A) | BOC | L48 | 154B3989 | 347.5 |
| RA1700 (B) | - | P65CF | 154-2404 | 600 |
| RA1700D | BOC | L48 | 154B3989 | 347.5 |
| RA1700T | BOC | L35-2 | 154-2190M1 | 270.5 |



1700

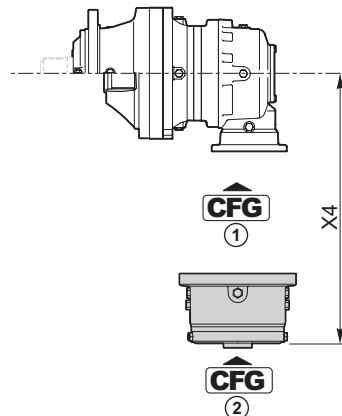
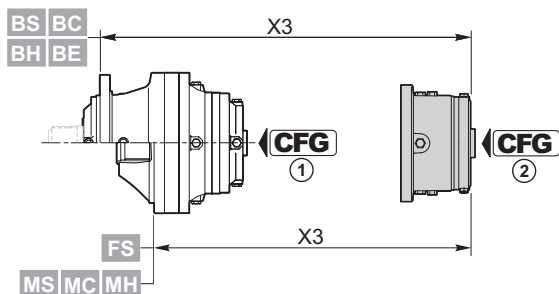
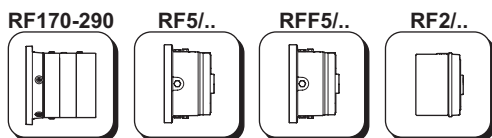

| RF170÷290 | CFG ① | T _f [Nm] | CFG ② | | |
|------------|-------|---------------------|------------|-----------------------------------|-----|
| | | | C | | |
| | | | code | X3 | X4 |
| RR1700 | RF | 1700 | 154B9766M2 | 367 (M...) 337 (FS) 470 (B) | - |
| | | 2000 | 154B9767M2 | | |
| | | 2300 | 154B9768M2 | | |
| | | 2900 | 154B9769M2 | | |
| RA1700 (B) | - | 1700 | 154B9766M3 | - | 485 |
| | | 2000 | 154B9767M3 | | |
| | | 2300 | 154B9768M3 | | |
| | | 2900 | 154B9769M3 | | |

| RF5/.. | CFG ① | T _f [Nm] | CFG ② | | | | | | |
|---------|-------|---------------------|----------|--|----|-------------------|-------------------|--|----|
| | | | B | | | OMTS 12/24 z16 | OMVS 10/20 z16 | | |
| | | | code | X3 | X4 | code | code | X3 | X4 |
| RR1700D | RF | 210 | 154-2872 | 336.5 (M...) 306.5 (FS) 438.5 (B...) | - | 154-2879 | 154-2886 | 340.2 (M...) 310.2 (FS) 442.2 (B...) | - |
| | | 290 | 154-2873 | | | 154-2880 | 154-2887 | | |
| | | 430 | 154-2874 | | | 154-2881 | 154-2888 | | |
| | | 650 | 154-2875 | | | 154-2882 | 154-2889 | | |
| | | 850 | 154-2876 | | | 154-2883 | 154-2890 | | |
| | | 1100 | 154-2877 | | | 154-2884 | 154-2891 | | |
| | | 1300 | 154-2878 | | | 154-2885 | 154-2892 | | |
| RR1700T | RF | 210 | 154-2872 | 403 (M...) 373 (FS) 505.5 (B...) | - | 154-2879 | 154-2886 | 406.7 (M...) 376.7 (FS) 509.2 (B...) | - |
| | | 290 | 154-2873 | | | 154-2880 | 154-2887 | | |
| | | 430 | 154-2874 | | | 154-2881 | 154-2888 | | |
| | | 650 | 154-2875 | | | 154-2882 | 154-2889 | | |
| | | 850 | 154-2876 | | | 154-2883 | 154-2890 | | |
| | | 1100 | 154-2877 | | | 154-2884 | 154-2891 | | |
| | | 1300 | 154-2878 | | | 154-2885 | 154-2892 | | |

| RFF5/.. | CFG ① | T _f [Nm] | CFG ② | | | | | | |
|------------|----------|---------------------|----------|----|-------|-------------------|-------------------|----|-------|
| | | | B | | | OMTS 12/24 z16 | OMVS 10/20 z16 | | |
| | | | code | X3 | X4 | code | code | X3 | X4 |
| RA1700 (A) | RF | 210 | 154-2893 | - | 316.6 | 154-5338 | 154-5345 | - | 320.5 |
| | | 290 | 154-2894 | | | 154-5339 | 154-5346 | | |
| | | 430 | 154-2895 | | | 154-5340 | 154-5347 | | |
| | | 650 | 154-2896 | | | 154-5341 | 154-5348 | | |
| | | 850 | 154-2897 | | | 154-5342 | 154-5349 | | |
| | | 1100 | 154-2898 | | | 154-5343 | 154-5350 | | |
| RA1700D | RF | 210 | 154-2893 | - | 316.6 | 154-5338 | 154-5345 | - | 320.5 |
| | | 290 | 154-2894 | | | 154-5339 | 154-5346 | | |
| | | 430 | 154-2895 | | | 154-5340 | 154-5347 | | |
| | | 650 | 154-2896 | | | 154-5341 | 154-5348 | | |
| | | 850 | 154-2897 | | | 154-5342 | 154-5349 | | |
| | | 1100 | 154-2898 | | | 154-5343 | 154-5350 | | |
| 1300 | 154-2899 | 154-5344 | 154-5351 | | | | | | |



| RF2/.. | CFG ① | T _f [Nm] | CFG ② | | | | | | |
|---------|----------|------------------------|------------|--|-----------------------------|------------------------------|-----------------------------|------------------------------|--|
| | | | B | | OMP/OMR SAE A 2B Ø 25 | OMP/OMR SAE A 2B 1" 6B | OMP/OMR SAE A 4B Ø 25 | OMP/OMR SAE A 4B 1" 6B | X3 |
| | | | code | X3 | code | code | code | code | |
| RR1700D | RF | 70 | 154B9195 | 309 (M...) 279 (FS) 411.5 (B...) | 154B9195M10 | — | 154B9195M16 | 154B9195M17 | 299 (M...) 269 (FS) 401.5 (B...) |
| | | 140 | 154B9196 | | 154B9196M10 | — | 154B9196M16 | 154B9196M17 | |
| | | 210 | 154B9197 | | 154B9197M10 | — | 154B9197M16 | 154B9197M17 | |
| | | 320 | 154B9198 | | 154B9198M10 | — | 154B9198M16 | 154B9198M17 | |
| | | 430 | 154B9199 | | 154B9199M10 | — | 154B9199M16 | 154B9199M17 | |
| | | 600 | 154B9200 | | 154B9200M10 | — | 154B9200M16 | 154B9200M17 | |
| RR1700T | RF | 70 | 154-2345 | 375.5 (M...) 345.5 (FS) 478 (B...) | 154-2345M10 | 154-2345M11 | 154-2345M16 | 154-2345M17 | 365.5 (M...) 335.5 (FS) 468 (B...) |
| | | 140 | 154-2346 | | 154-2346M10 | 154-2346M11 | 154-2346M16 | 154-2346M17 | |
| | | 210 | 154-2347 | | 154-2347M10 | 154-2347M11 | 154-2347M16 | 154-2347M17 | |
| | | 320 | 154-2348 | | 154-2348M10 | 154-2348M11 | 154-2348M16 | 154-2348M17 | |
| | | 430 | 154-2349 | | 154-2349M10 | 154-2349M11 | 154-2349M16 | 154-2349M17 | |
| | | 600 | 154B9186 | | 154B9186M10 | 154B9186M11 | 154B9186M16 | 154B9186M17 | |
| RR1700Q | RF | 70 | 154-2838M1 | 417 (M...) 387 (FS) 519.5 (B...) | 154-2863 | 154-2863M11 | 154-2635 | 154-2635M11 | 407 (M...) 377 (FS) 509.5 (B...) |
| | | 140 | 154-2839M1 | | 154-2864 | 154-2864M11 | 154-2636 | 154-2636M11 | |
| | | 210 | 154-2840M1 | | 154-2865 | 154-2865M11 | 154-2637 | 154-2637M11 | |
| | | 320 | 154-2841M1 | | 154-2866 | 154-2866M11 | 154-2638 | 154-2638M11 | |
| | | 430 | 154-2842M1 | | 154-2867 | 154-2867M11 | 154-2639 | 154-2639M11 | |
| | | 600 | 154B8962M1 | | 154B9665 | 154B9665M11 | 154B9666 | 154B9666M11 | |

| | CFG ① | T _f [Nm] | CFG ② | | | | | | |
|------------|----------|------------------------|-------------|-------|-----------------------------|------------------------------|-----------------------------|------------------------------|-------|
| | | | B | | OMP/OMR SAE A 2B Ø 25 | OMP/OMR SAE A 2B 1" 6B | OMP/OMR SAE A 4B Ø 25 | OMP/OMR SAE A 4B 1" 6B | X4 |
| | | | code | X4 | code | code | code | code | |
| RA1700 (A) | RF | 70 | 154F2991 | 285.3 | | | | | |
| | | 140 | 154F1890 | | | | | | |
| | | 210 | 154F2961 | | | | | | |
| | | 320 | 154B3591 | | | | | | |
| | | 430 | 154B3592 | | | | | | |
| | | 600 | 154F2992 | | | | | | |
| RA1700D | RF | 70 | 154F2991 | 285.3 | | | | | |
| | | 140 | 154F1890 | | | | | | |
| | | 210 | 154F2961 | | | | | | |
| | | 320 | 154B3591 | | | | | | |
| | | 430 | 154B3592 | | | | | | |
| | | 600 | 154F2992 | | | | | | |
| RA1700T | RF | 70 | 154-2838M12 | 223.8 | 154-2863M12 | 154-2863M13 | 154-2635M12 | | 213.8 |
| | | 140 | 154-2839M12 | | 154-2864M12 | 154-2864M13 | 154-2636M12 | | |
| | | 210 | 154-2840M12 | | 154-2865M12 | 154-2865M13 | 154-2637M12 | | |
| | | 320 | 154-2841M12 | | 154-2866M12 | 154-2866M13 | 154-2638M12 | | |
| | | 430 | 154-2842M12 | | 154-2867M12 | 154-2867M13 | 154-2639M12 | | |
| | | 600 | 154B8962M12 | | 154B9665M12 | 154B9665M13 | 154B9666M12 | | |

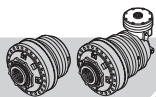

1700

IT EN DE FR ES PT

12

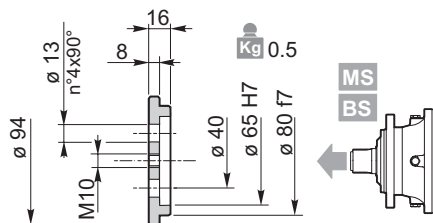

154-3062

Materiale / Material / Material / Matériau / Material / Material:
Acciaio / Steel / Stahl / Acier / Acero / Aço
C40 EN 10083-1 (1.1186)

28

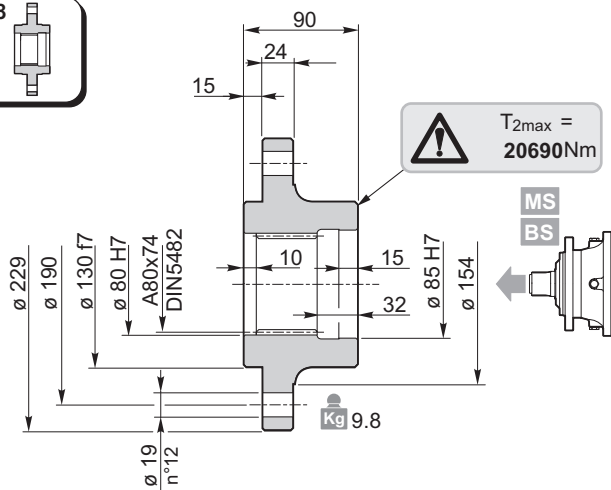

154-3359

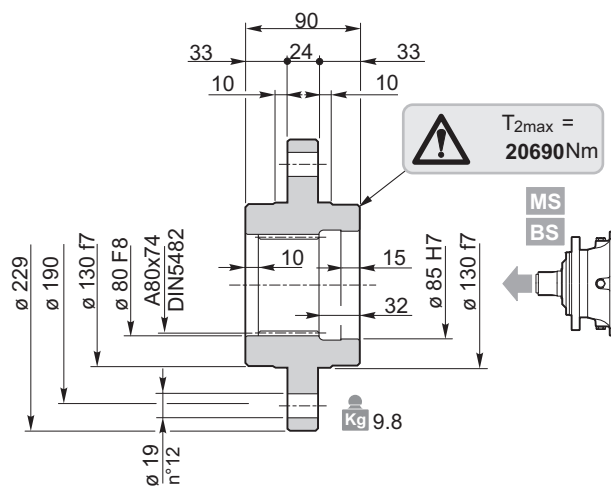

154-3112

Materiale / Material / Material / Matériau / Material / Material:
Acciaio / Steel / Stahl / Acier / Acero / Aço
EN 10083-1-C40 (1.1186)

Trattamento termico:
 Tempra ad induzione secondo UNI 10932 su scanalato interno

Heat treatment:
 Induction hardening according to UNI 10932 on internal spline

Wärmebehandlung:
 Induktionshärtung nach UNI 10932 an interner Nut

Traitement thermique :
 Trempe par induction conformément à la norme UNI 10932 sur cannelé interne

Tratamiento térmico:
 Temple por inducción según UNI 10932 en acanalado interno

Tratamento térmico:
 Tempera por indução segundo UNI 10932 sobre ranhuras internas

29

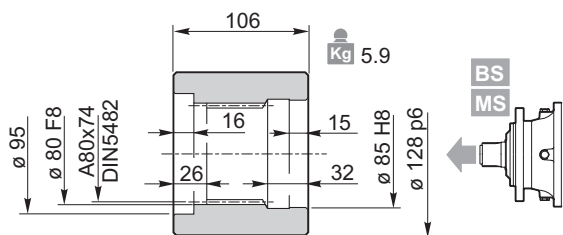

154-3093

Materiale / Material / Material / Matériau / Material / Material:
Acciaio / Steel / Stahl / Acier / Acero / Aço
39NiCrMo3 UNI 7845 (1.6511)

Trattamento termico:
 Tempra ad induzione secondo UNI 10932 su scanalato interno

Heat treatment:
 Induction hardening according to UNI 10932 on internal spline

Wärmebehandlung:
 Induktionshärtung nach UNI 10932 an interner Nut

Traitement thermique :
 Trempe par induction conformément à la norme UNI 10932 sur cannelé interne

Tratamiento térmico:
 Temple por inducción según UNI 10932 en acanalado interno

Tratamento térmico:
 Tempera por indução segundo UNI 10932 sobre ranhuras internas

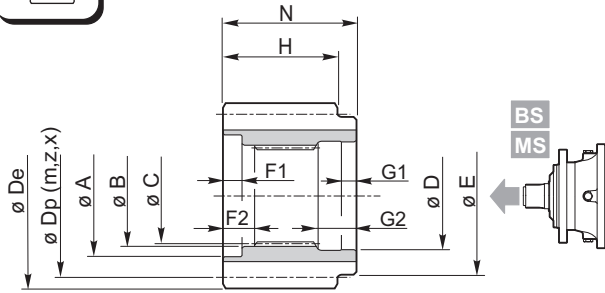
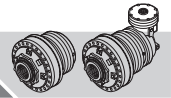

Materiale / Material / Material
 Matériau / Material / Material
 Acciaio / Steel / Stahl / Acier / Acero / Aço
 39NiCrMo3 UNI 7845 (1.6511)

Trattamento termico:
 Tempra ad induzione secondo UNI 10932 su scanalato interno

Heat treatment:
 Induction hardening according to UNI 10932 on internal spline

Wärmebehandlung:
 Induktionshärtung nach UNI 10932 an interner Nut

Traitement thermique:
 Trempe par induction conformément à la norme UNI 10932 sur cannelé interne

Tratamiento térmico:
 Temple por inducción según UNI 10932 en acanalado interno

Tratamento térmico:
 Tempera por indução segundo UNI 10932 sobre ranhuras internas

| | A | B | C | D | E | F1 | F2 | G1 | G2 | N | m | z | x | H | Dp | De | Code |
|----------|----|-------|-------------------|-------|-----|----|----|----|----|-----|----|----|-------|----|-----|-------|----------|
| BS MS | 96 | 80 F8 | DIN5482 A80x74 | 85 H8 | 124 | 15 | 25 | 12 | 30 | 105 | 8 | 17 | 0.5 | 90 | 136 | 159 | 154-3071 |
| | 96 | 80 F8 | DIN5482 A80x74 | 85 H8 | 124 | 15 | 25 | 12 | 30 | 105 | 10 | 12 | 0.425 | 90 | 120 | 146 | 154-3081 |
| | 96 | 80 F8 | DIN5482 A80x74 | 85 H8 | 105 | 15 | 25 | 12 | 30 | 105 | 10 | 12 | 0.5 | 90 | 120 | 148 | 154B3834 |
| | 96 | 80 F8 | DIN5482 A80x74 | 85 H8 | 124 | 15 | 25 | 12 | 30 | 105 | 10 | 15 | 0 | 90 | 150 | 169 | 154-3069 |
| | 96 | 80 F8 | DIN5482 A80x74 | 85 H8 | 124 | 15 | 25 | 12 | 30 | 105 | 10 | 18 | 0 | 90 | 180 | 198.5 | 154-3044 |
| | 96 | 80 F8 | DIN5482 A80x74 | 85 H8 | 130 | 15 | 25 | 12 | 30 | 105 | 12 | 14 | 0.25 | 90 | 168 | 194.5 | 154-3080 |

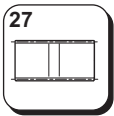

kg 6.5

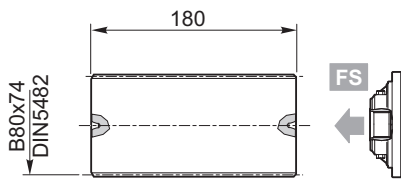

154-3054

Materiale / Material / Material
 Matériau / Material / Material:
 Acciaio / Steel / Stahl / Acier / Acero / Aço
 39NiCrMo3 UNI 7845 (1.6511)

T_{2max} =
21100Nm

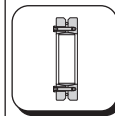

kg 22

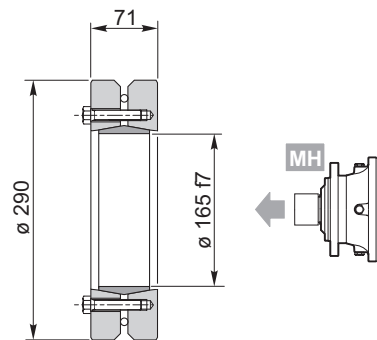

154F6499

C36

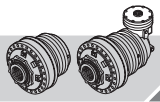

1700

IT EN DE FR ES PT

| | | | |
|----|------|----|-----------|
| RR | 1700 | .. | MS |
| RA | | | MC |

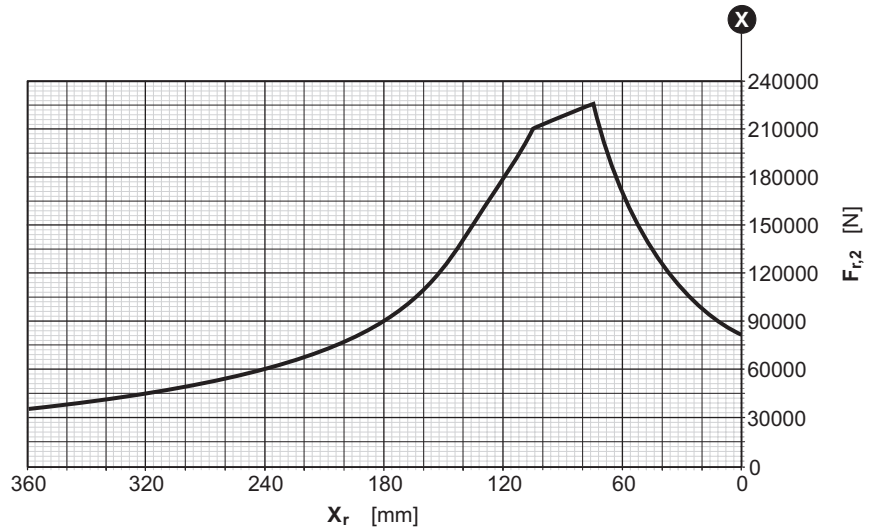
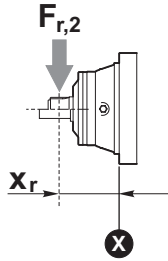

| | | | |
|----|------|----|-----------|
| RR | 1700 | .. | BS |
| RA | | | BC |

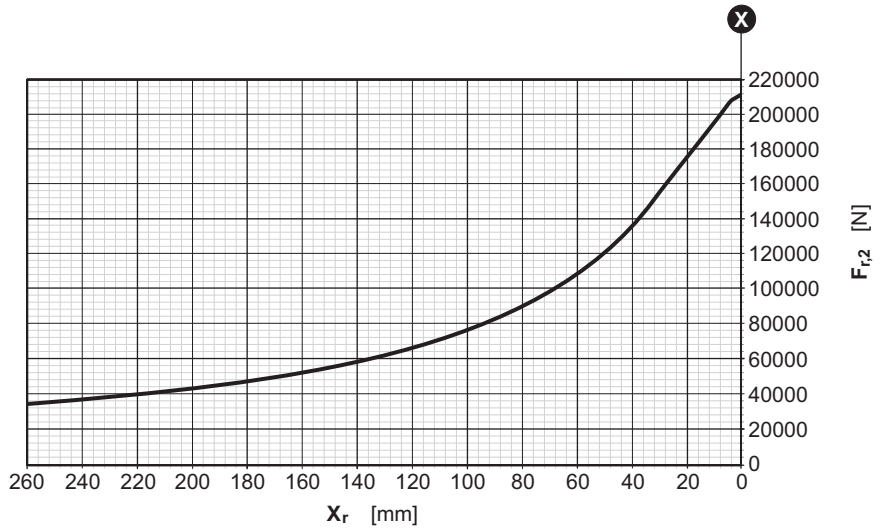
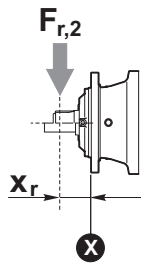

| | | | |
|----|------|----|-----------|
| RR | 1700 | .. | BE |
|----|------|----|-----------|

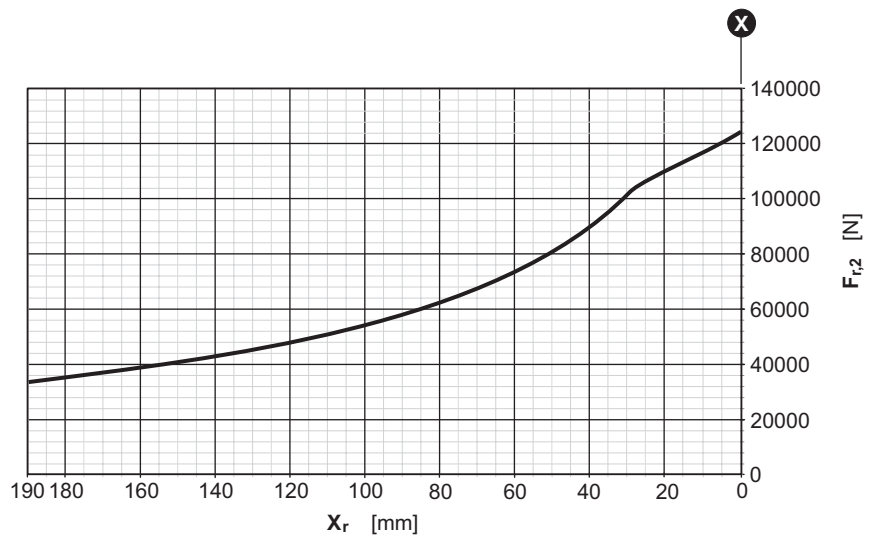
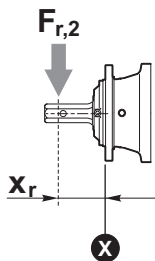

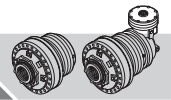

| | | | |
|----|------|----|----------|
| RR | 1700 | .. | VI ZI |
|----|------|----|----------|

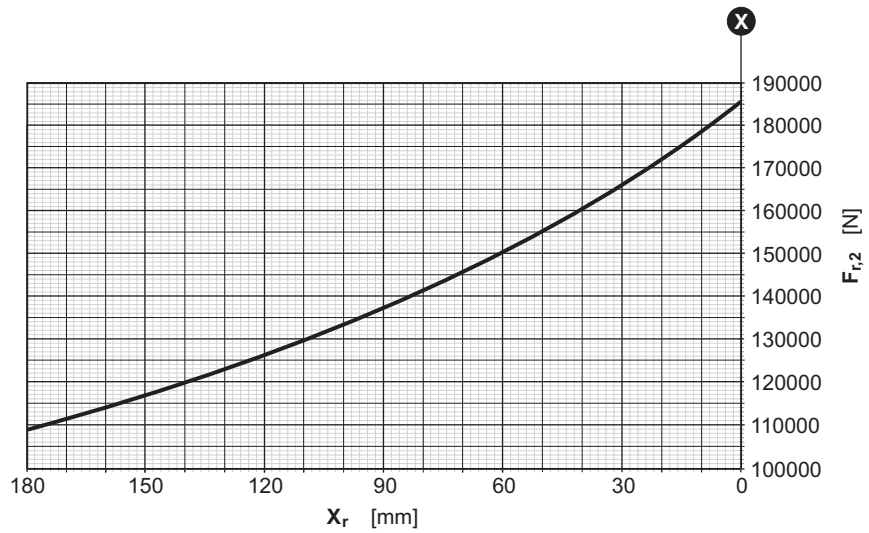
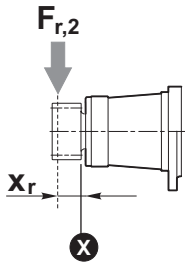

Fattore correttivo k_{r2} / k_{r2} Corrective coefficient / Korrekturfaktor k_{r2}
 Facteur correctif k_{r2} / Factor de corrección k_{r2} / Fator corretivo k_{r2}

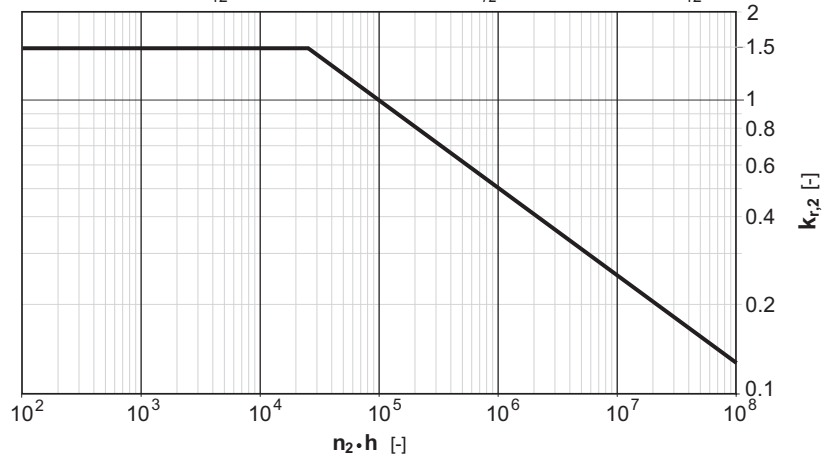



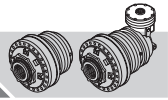

C

Configurazioni e accessori in ingresso, installazione
Input configurations and accessories, installation
Konfigurationen und Zubehör am Eingang, Installation
Configurations et accessoires à l'entrée, installation
Configuraciones y accesorios en entrada, instalación
Configurações e acessórios entrada, instalação

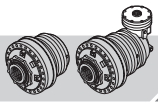

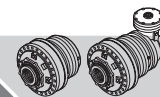
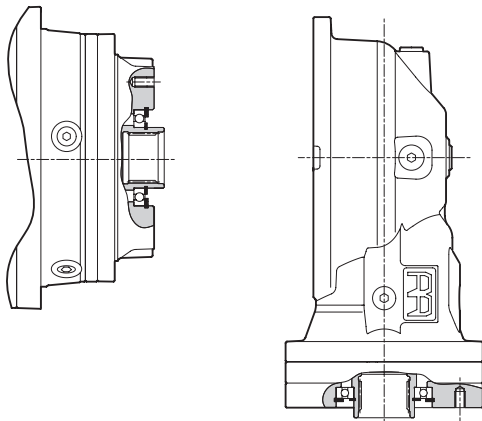
**Ingresso standard / Standard input / Standardeingang
Entrée standard / Entrada standard / Entrada padrão**
(—)
**A
B
C**

Dimensioni di ingresso per i tipi A, B, C riportate nel dettaglio nelle pagine seguenti.

Dimensions d'entrée pour les types A, B, C figurant dans le détail sur les pages suivantes.

Input dimensions for types A, B, C are detailed on the next pages.

Dimensiones de entrada para los tipos A, B, C indicadas detalladamente en las páginas siguientes.

Die Abmessungen vom Eingang für die Typen A, B und C sind detailliert auf den folgenden Seiten angegeben.

Dimensões de entrada para os tipos A, B, C indicadas detalhadamente nas páginas seguintes.

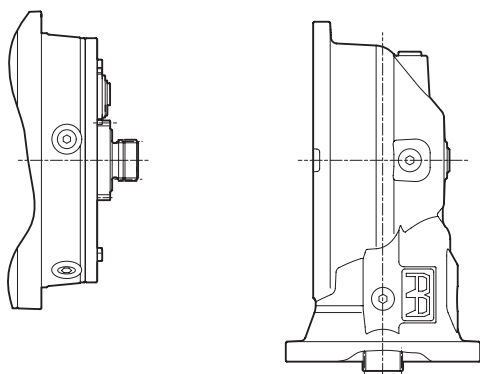
**Predisposizione RF / RF Setup / Auslegung RF
Préréglage RF / Predisposición RF / Predisposição RF**
(RF)

Entrata diretta in corona e pignone solare; dimensioni di ingresso variabili in base alla grandezza del riduttore, fornibili su richiesta. Consente il montaggio di freni, accoppiamenti motore ed altri accessori.

Entrée directe en couronne et pignon solaire; dimensions d'entrée variables en fonction de la grandeur du réducteur, communiquées sur simple demande. Elle permet de monter les freins, les accouplements moteur et d'autres accessoires.

Direct input in the crown and sun gears; input dimensions vary according to gear size, can be supplied on request. It allows brakes, motor couplings and other accessories to be mounted.

Entrada directa en corona y piñón solar; dimensiones de entrada variables según el tamaño del reductor, proporcionables a petición. Permite el montaje de frenos, acoplamientos motor y otros accesorios.

Direkter Eingang an Kranz und Planetenrad. Die Abmessungen vom Eingang variieren je nach Größe vom Untersetzungsgetriebe und sind auf Wunsch erhältlich. Erlaubt die Montage von Bremsen, Motorkupplungen und anderem Zubehör.

Entrada direta em coroa e pinhão solar; dimensões de entrada variáveis conforme a grandeza do reductor, fornecidos a pedido. Consente a montagem de freios, acoplagens do motor e outros acessórios.

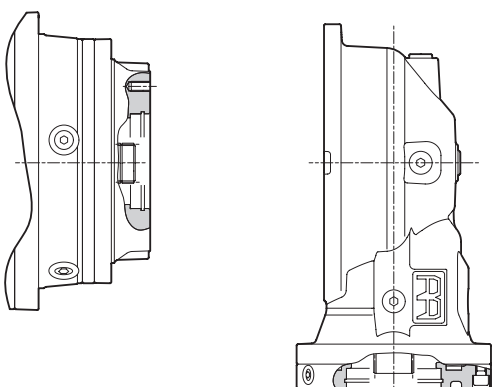
**Predisposizione BOC / BOC Setup / Auslegung BOC
Préréglage BOC / Predisposición BOC / Predisposição BOC**
(BOC)

Come ingresso standard ma con pignone solare; dimensioni di ingresso variabili in base alla grandezza del riduttore, fornibili su richiesta. Consente il montaggio di accoppiamenti motore ed altri accessori.

Comme entrée standard mais avec pignon solaire; dimensions d'entrée variables en fonction de la grandeur du réducteur, communiquées sur simple demande. Elle permet de monter les accouplements moteur et d'autres accessoires.

Like the standard input but with a sun gear; input dimensions vary according to gear size, can be supplied on request. It allows motor couplings and other accessories to be mounted.

Como entrada standard, pero con piñón solar; dimensiones de entrada variables según el tamaño del reductor, proporcionables a petición. Permite el montaje de acoplamientos motor y otros accesorios.

Wie Standardeingang, aber mit Planetenrad. Die Abmessungen vom Eingang variieren je nach Größe vom Untersetzungsgetriebe und sind auf Wunsch erhältlich. Erlaubt die Montage von Motorkupplungen und anderem Zubehör.

Como entrada padrão mas com pinhão solar; dimensões de entrada variáveis conforme a grandeza do reductor, fornecidos a pedido. Consente a montagem de acoplagens do motor e outros acessórios.

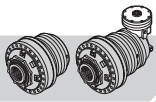

Ingresso standard / *Standard input* / *Standerdeingang*
 Entrée standard / *Entrada standard* / *Entrada padrão*

A

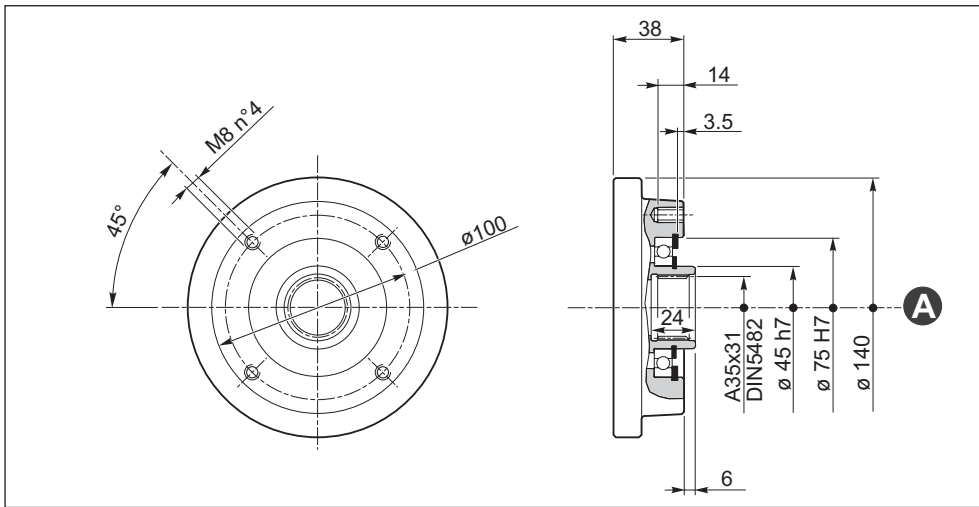

RF2

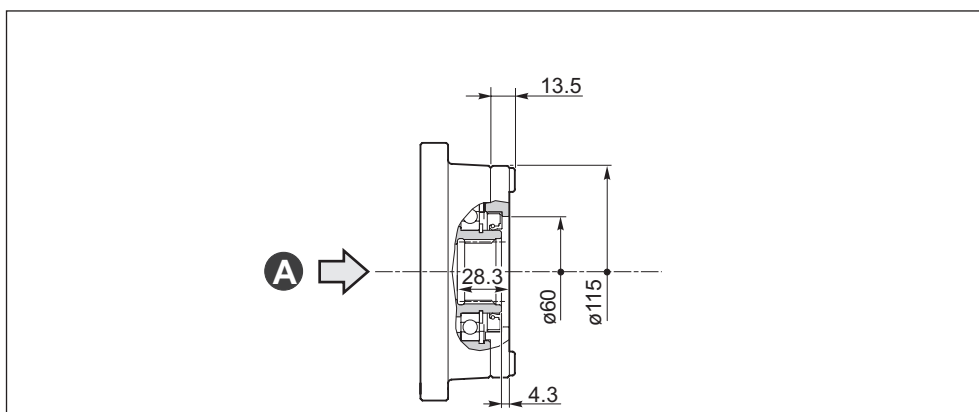
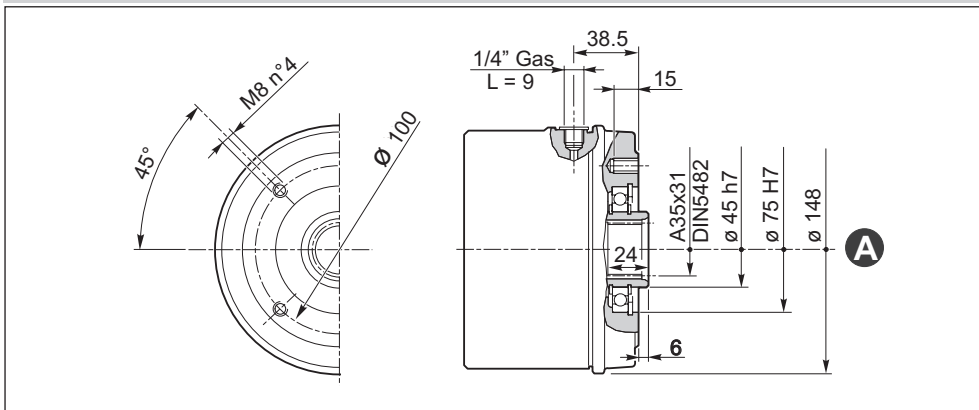

154-2300M325

Kit di chiusura per entrata tipo **(A)** completo di tenuta paraolio.

Closing kit for type (A) input, complete with oil seal.

Verschlussatz für Eingang Typ (A) komplett mit Ölabdichtung.

Kit de fermeture pour entrée type (A) avec joint étanche à l'huile.

Kit de cierre para entrada de tipo (A) completo de sello de aceite.

Kit de encerramento para entrada de tipo (A) munido de vedação pára-óleo.

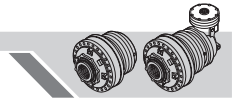

Ingresso standard / Standard input / Standardeingang
 Entrée standard / Entrada standard / Entrada padrão

B

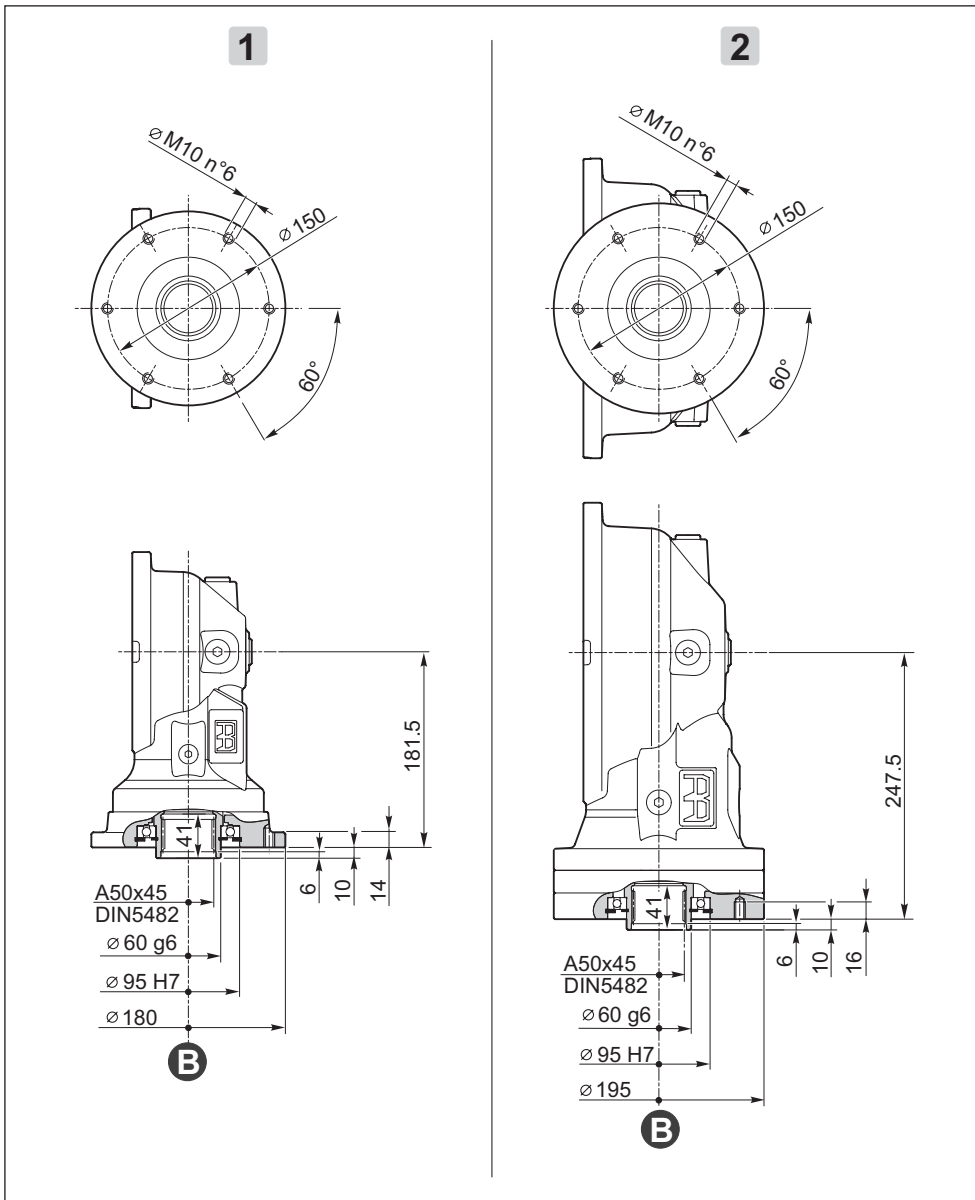
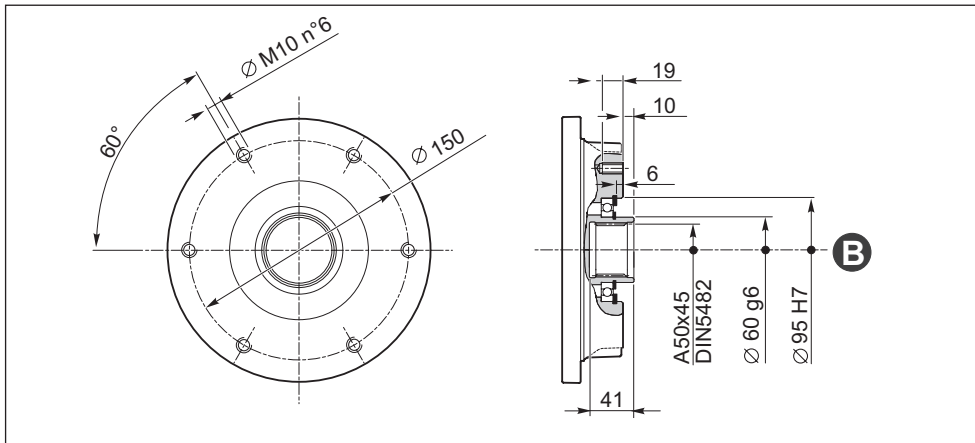

1

| |
|-------------------------|
| RA105 / RA105D |
| RA110 / RA110D |
| RA210 / RA210D |
| RA310 / RA310D / RA310T |
| RA510D / RA510T |
| RA710D / RA710T |
| RA810D / RA810T |
| RA1010T |
| RA1700T |

2

| |
|----------------------|
| RA510 |
| RA710 |
| RA1010 (A) / RA1010D |
| RA1700 (A) / RA1700D |

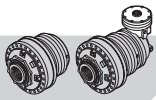

Ingresso standard / *Standard input* / Standardeingang
 Entrée standard / *Entrada standard* / Entrada padrão

B

RF2

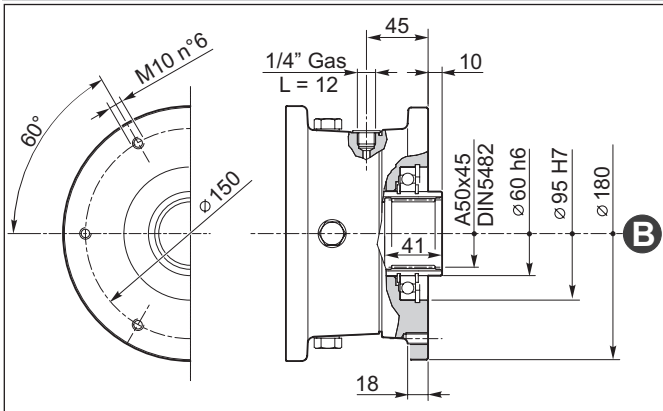

RF5

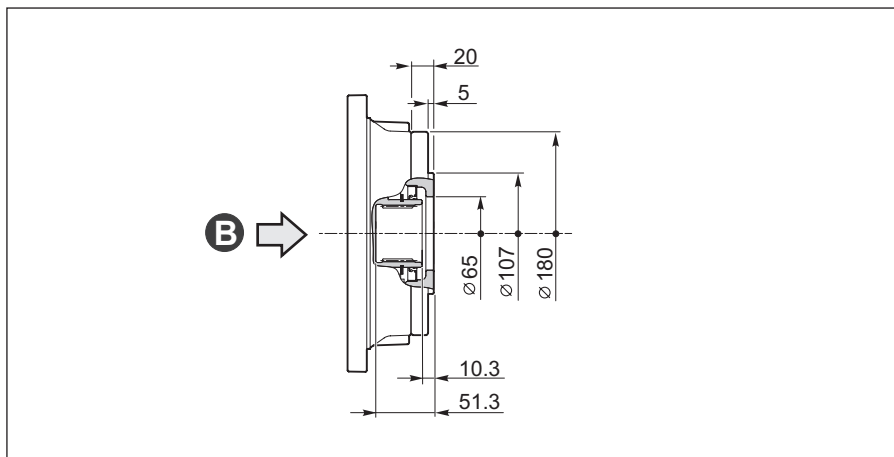
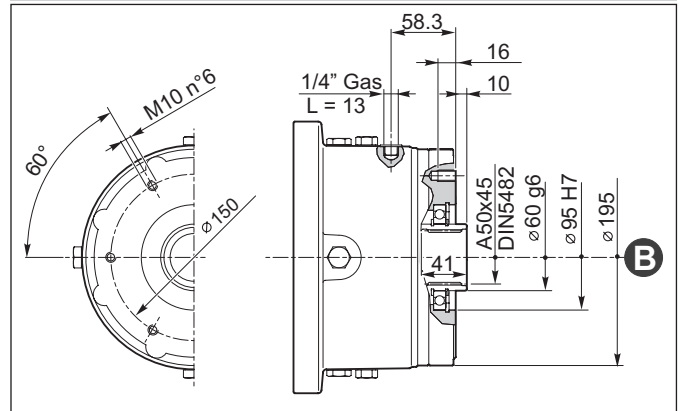

154-2300M324

Kit di chiusura per entrata tipo **(B)** completo di tenuta paraolio.

Closing kit for type (B) input, complete with oil seal.

Verschlussatz für Eingang Typ **(B)** komplett mit Ölabdichtung.

Kit de fermeture pour entrée type **B** avec joint étanche à l'huile.

Kit de cierre para entrada de tipo (B) completo de sello de aceite.

Kit de encerramento para entrada de tipo **B** munido de vedação para-óleo.

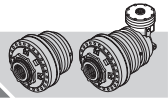

Ingresso standard / Standard input / Standardeingang
 Entrée standard / Entrada standard / Entrada padrão

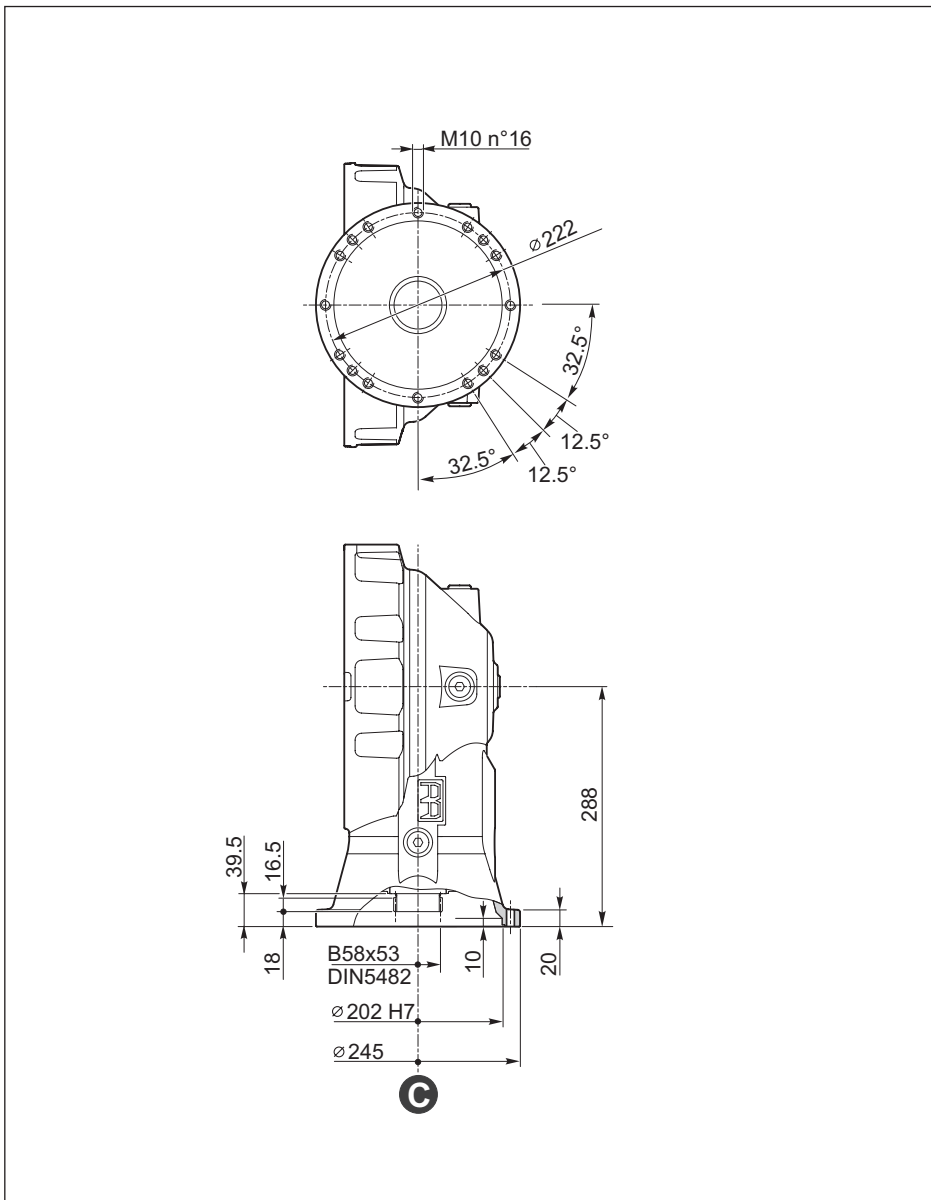
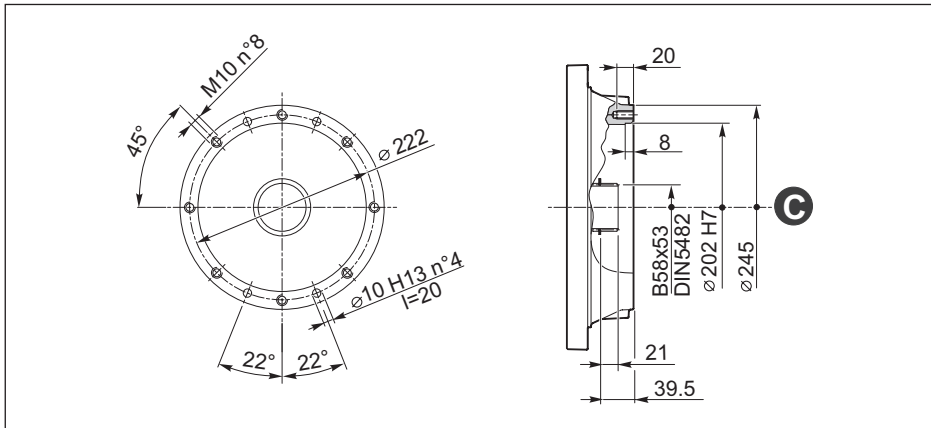

| |
|------------|
| RA1010 (B) |
| RA1700 (B) |

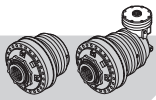

Ingresso standard / Standard input / Standardeingang
Entrée standard / Entrada standard / Entrada padrão

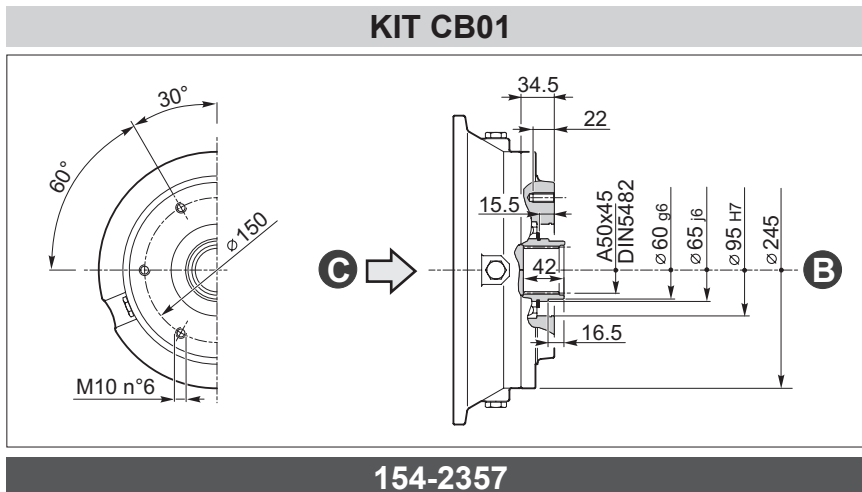
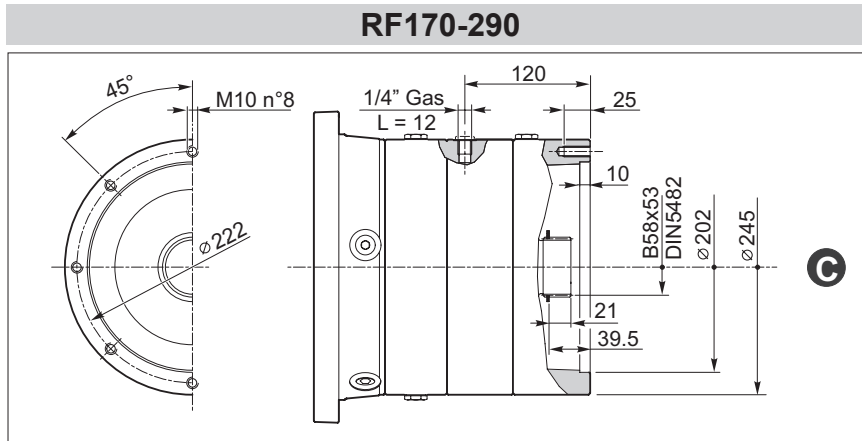

154-2357

(RR810 - RR1010 / RA1010 (B) - RR1700 / RA1700 (B))

Kit di trasformazione ingresso per riduttori lineari e angolari e di trasformazione per freni RF170-290; trasforma l'ingresso tipo (C) in ingresso tipo (B) consentendo il montaggio di ulteriori accoppiamenti motore.
Consultare le apposite tabelle degli accoppiamenti per verificare la compatibilità.

*Input transformation kit for linear and angular reduction gears and for RF170-290 brakes; transforms a type (C) input into a type (B) input so that other motor couplings can be mounted.
Please consult the relative couplings tables to check compatibility.*

Satz zur Umwandlung vom Eingang für Linear- und Winkelgetriebe und für Bremsen RF170-290. Wandelt den Eingang vom Typ (C) in einen Eingang vom Typ (B) um und erlaubt so die Montage weiterer Motorkupplungen.
Die Kompatibilität anhand der Tabellen der Kupplungen prüfen.

Kit de transformation de l'entrée pour réducteurs linéaires, angulaires et pour les freins RF170-290; transforme l'entrée type (C) en entrée type (B) pour le montage d'accouplements supplémentaires au moteur.
Voir les tableaux des accouplements pour s'assurer de la compatibilité.

*Kit de transformación de entrada para reductores lineales, angulares y para los frenos RF170-290; transforma la entrada de tipo (C) en entrada de tipo (B), permitiendo el montaje de ulteriores acoplamientos motor.
Consúltense las correspondientes tablas de los acoplamientos para comprobar la compatibilidad.*

Kit de transformação entrada para reductores lineares, angulares e para freios RF170-290; transforma a entrada de tipo (C) em entrada de tipo (B) consentindo a montagem de outras acoplagens de motor.
Consultar as respetivas tabelas das acoplagens para verificar a compatibilidade.

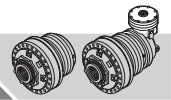

L35-1

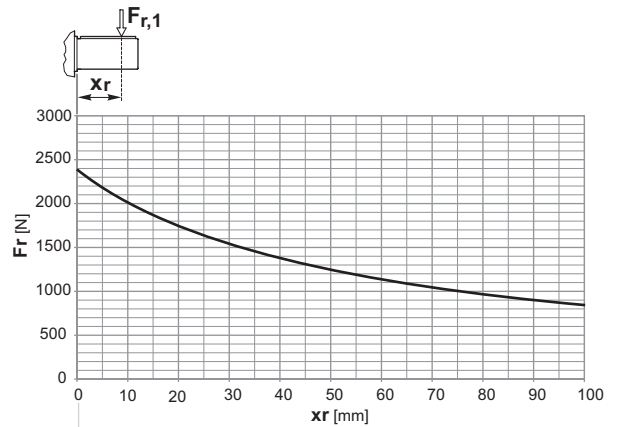
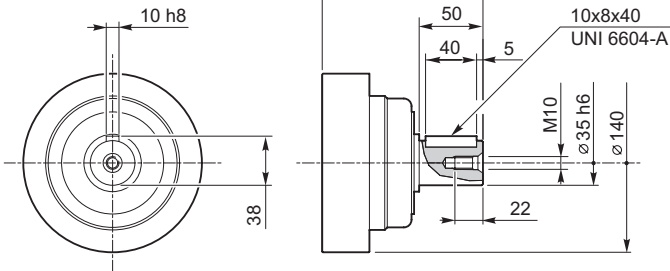

L35-2

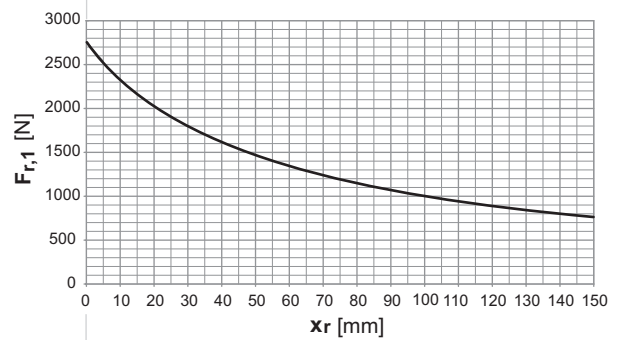
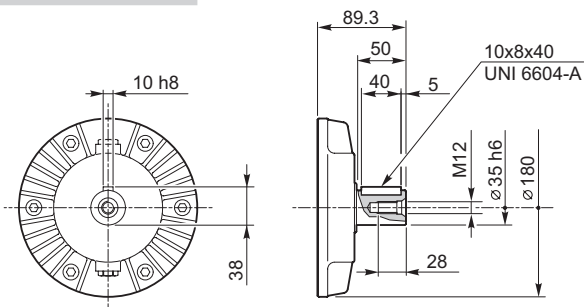

L48

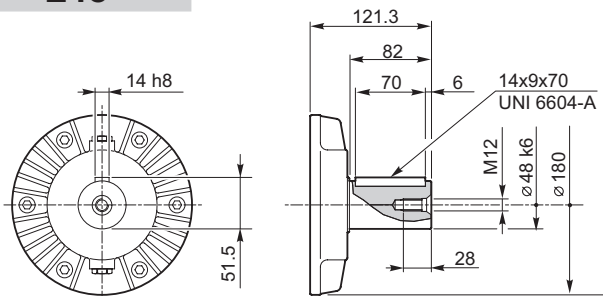

M65CF

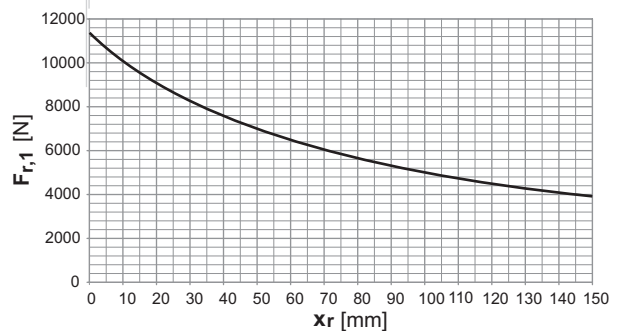
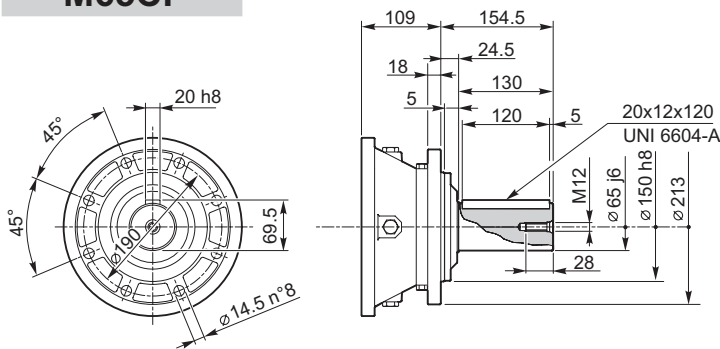

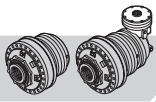

M65SF

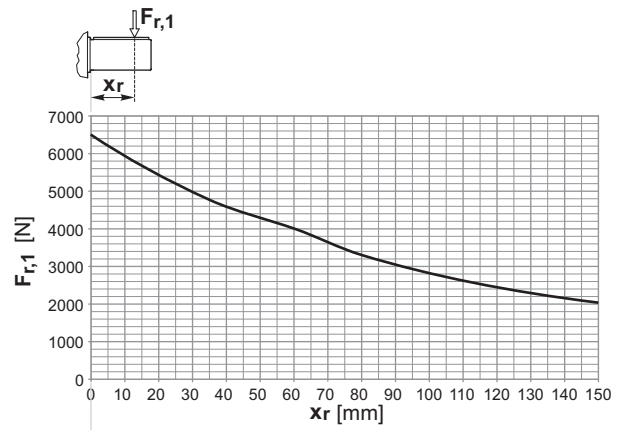
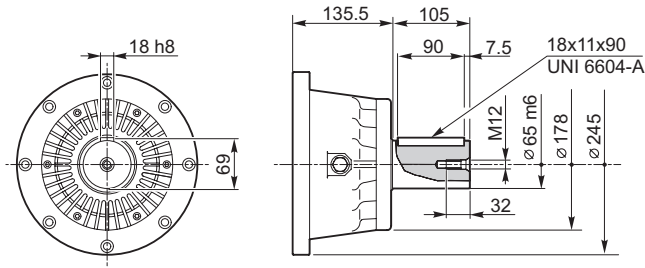

P65CF

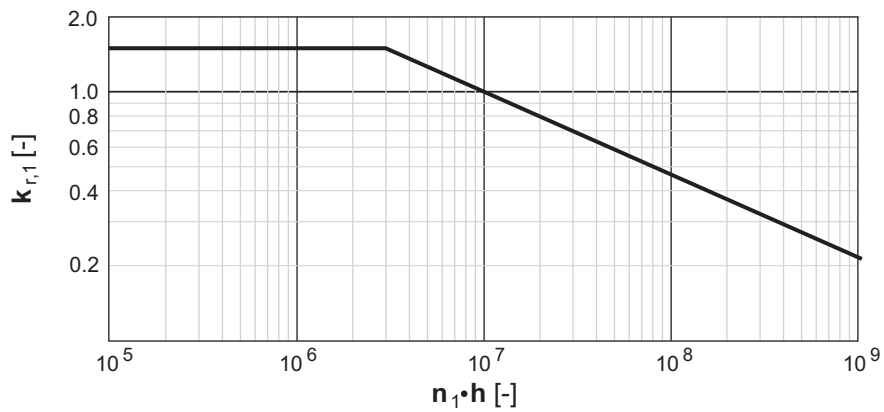
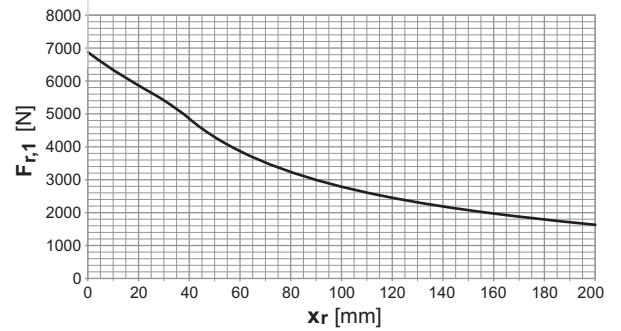
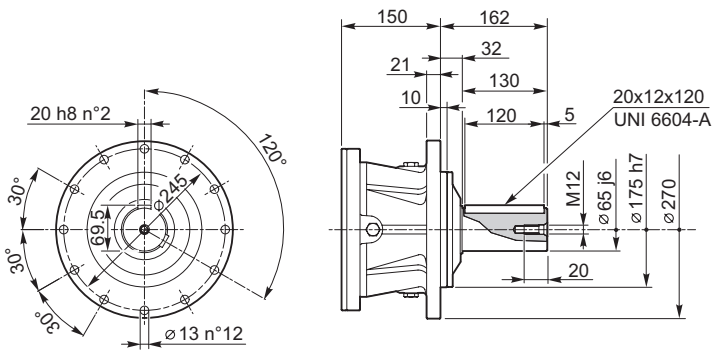



RF2/..

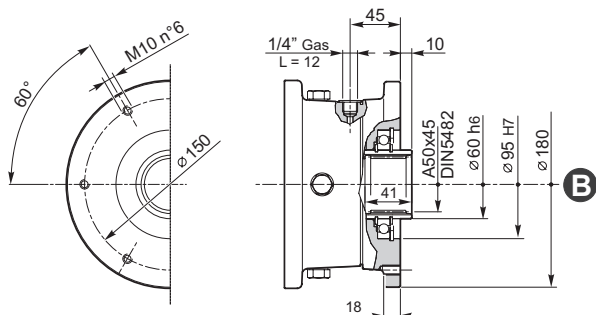

| RF2/.. | | RF2/7 | RF2/14 | RF2/21 | RF2/32 | RF2/43 | RF2/60 |
|-----------|----------------------|---------|-----------|-----------|-----------|-----------|-----------|
| T_F | [Nm] | 60 ÷ 80 | 130 ÷ 150 | 200 ÷ 220 | 310 ÷ 340 | 410 ÷ 450 | 570 ÷ 600 |
| p_a min | [bar] | 4 ÷ 5 | 8 ÷ 9 | 12 ÷ 13 | 18 ÷ 20 | 24 ÷ 26 | 27 ÷ 32 |
| p_{ac} | [bar] | 40 | | | | | |
| p_a max | [bar] | 250 | | | | | |
| V_{ca} | [cm ³] | 7 ÷ 8 | | | | | |
| M | [kg] | 10.5 | | | | | |
| V_s | — | VG 150 | | | | | |
| n_1 max | [min ⁻¹] | 1500 | | | | | |

RF5/..- RFF5/..

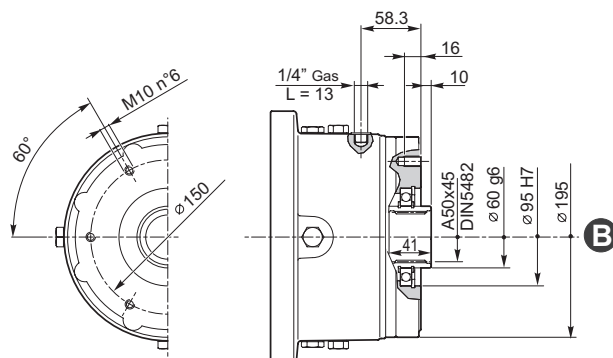

| RF5/.. RFF5/.. | | RF5/21 RFF5/21 | RF5/29 RFF5/29 | RF5/43 RFF5/43 | RF5/65 RFF5/65 | RF5/85 RFF5/85 | RF5/110 RFF5/110 | RF5/130 RFF5/130 |
|-------------------|----------------------|-------------------|-------------------|-------------------|-------------------|-------------------|---------------------|---------------------|
| T_F | [Nm] | 180 ÷ 230 | 280 ÷ 330 | 420 ÷ 460 | 610 ÷ 700 | 830 ÷ 920 | 1080 ÷ 1180 | 1260 ÷ 1360 |
| p_a min | [bar] | 4 ÷ 5 | 6 ÷ 7 | 9 ÷ 10 | 13 ÷ 15 | 18 ÷ 20 | 23 ÷ 25 | 27 ÷ 29 |
| p_{ac} | [bar] | 40 | | | | | | |
| p_a max | [bar] | 250 | | | | | | |
| V_o max | [l] | 0.30/0.60 | | | | | | |
| V_{ca} | [cm ³] | 8 ÷ 9 | | | | | | |
| M | [kg] | 21 | | | | | | |
| V_s | — | VG 32 | | | | | | |
| n_1 max | [min ⁻¹] | 1000 | | | | | | |

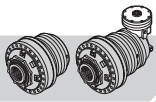

RF170 ÷ 290

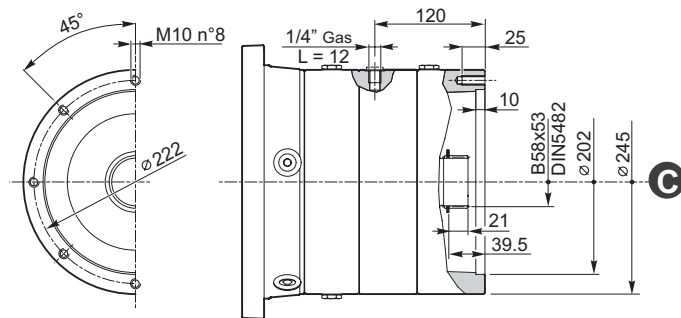

| RF170 ÷ 290 | | RF170 | RF200 | RF230 | RF290 |
|-------------|----------------------|-----------|---------|---------|---------|
| T_F | [Nm] | 1700 | 1980 | 2260 | 2830 |
| p_a min | [bar] | 25 ÷ 27 | 22 ÷ 24 | 25 ÷ 27 | 25 ÷ 27 |
| p_{ac} | [bar] | 40 | | | |
| p_a max | [bar] | 250 | | | |
| V_o max | [l] | 0.45/0.90 | | | |
| V_{ca} | [cm ³] | 27 ÷ 30 | | | |
| M | [kg] | 64 | | | |
| V_s | — | VG 32 | | | |
| n_1 max | [min ⁻¹] | 750 | | | |

I freni RF2/.. condividono la lubrificazione con il riduttore; per i freni RF5/.. RFF5/.. e RF170÷290 si consiglia l'uso di olio minerale di tipo idraulico con viscosità ISO VG 32. In ogni caso per il comando dell'apertura del freno utilizzare olio minerale o sintetico di tipo idraulico con viscosità ISO VG 32. Non utilizzare oli vegetali.

L'huile lubrifiante pour typologie de Freins RF2/ est la même que celle qui est utilisée pour la lubrification du réducteur ; pour la lubrification des freins de typologie RF5/.. RFF5/.. et RF170-290, il est conseillé d'utiliser une huile minérale de type hydraulique avec une viscosité ISO VG 32. Dans tous les cas, pour la commande de l'ouverture du frein, utilisez de l'huile minérale ou synthétique de type hydraulique avec viscosité ISO VG 32. Ne pas utiliser d'huiles végétales.

The RF2/.. brakes share the same lubrication with the reduction gear; we recommend using a hydraulic type mineral oil with an ISO VG 32 viscosity for the RF5/.. RFF5/.. e RF170÷290 brakes.

In all cases use either a mineral or synthetic hydraulic oil with an ISO VG 32 viscosity for the brake opening control. Do not use vegetable oils.

Los frenos RF2/.. comparten la lubricación con el reductor; para los frenos RF5/.. RFF5/.. y RF170÷290 se aconseja utilizar aceite mineral de tipo hidráulico con viscosidad ISO VG 32.

En todo caso, para el mando de la apertura del freno, utilizar aceite mineral o sintético de tipo hidráulico con viscosidad ISO VG 32. No utilizar aceites vegetales.

Die Bremsen RF2/... teilen die Schmierung mit dem Untersetzungsgetriebe: Für die Bremsen RF5/.. RFF5/.. und RF170-290 wird die Verwendung von Mineralöl vom hydraulischen Typ mit einer Viskosität von ISO VG 32 geraten.

Für die Steuerung des Öffnens der Bremse muss ein Mineralöl oder synthetisches Öl vom hydraulischen Typ mit einer Viskosität von ISO VG 32 verwendet werden. Auf keinen Fall pflanzliche Öle verwenden!

Os freios RF2/.. compartilham a lubrificação com o reductor; para freios RF5/.., RFF5/.. e RF 170÷290 aconselhamos o uso de óleo mineral de tipo hidráulico com viscosidade ISO VG 32.

Em todo o caso, para o comando da abertura do freio usar óleo mineral ou sintético de tipo hidráulico com viscosidade ISO VG 32. Nunca usar óleos vegetais.

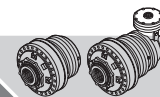

| | | Legenda | Legend | Zeichenerklärung |
|-----------|----------------------|---|---|--|
| T_F | [Nm] | Coppia statica | <i>Static torque</i> | Statisches Drehmoment |
| p_a min | [bar] | Min. pressione di apertura | <i>Min. opening pressure</i> | Mindestöffnungsdruck |
| p_{ac} | [bar] | Pressione di apertura consigliata | <i>Recommended opening pressure</i> | Empfohlener Öffnungsdruck |
| p_a max | [bar] | Max. pressione di apertura | <i>Max. opening pressure</i> | Max. Öffnungsdruck |
| V_o max | [l] | Volume di olio lubrificante (Orizzontale/Verticale) | <i>Lubricating oil volume (Horizontal/Vertical)</i> | Menge Schmieröl (horizontal/vertikal) |
| V_s | | Viscosità consigliata per l'olio di lubrificazione | <i>Recommended viscosity for the lubricant oil</i> | Empfohlene Viskosität für Schmieröl |
| V_{ca} | [cm ³] | Min. volume di olio comando apertura freno | <i>Min. volume of oil to control brake opening</i> | Mindestmenge Öl Steuerung Bremsenöffnung |
| M | [kg] | Massa | <i>Mass</i> | Gewicht |
| n_1 max | [min ⁻¹] | Max. giri in ingresso | <i>Max. revs in input</i> | Max. Drehzahl am Eingang |

| | | Légende | Leyenda | Legenda |
|-----------|----------------------|---|--|--|
| T_F | [Nm] | Couple statique | <i>Par estático</i> | Par estático |
| p_a min | [bar] | Pression d'ouverture minimum | <i>Presión mín. de apertura</i> | Min. pressão de abertura |
| p_{ac} | [bar] | Pression d'ouverture conseillée | <i>Presión de apertura aconsejada</i> | Pressão de abertura aconselhável |
| p_a max | [bar] | Pression d'ouverture maximum | <i>Presión máx. de apertura</i> | Max. pressão de abertura |
| V_o max | [l] | Volume d'huile lubrifiante (horizontal/vertical) | <i>Volumen de aceite lubricante (Horizontal/Vertical)</i> | Volume de óleo lubrificante (Horizontal/Vertical) |
| V_s | | Viscosité conseillée pour l'huile de lubrification | <i>Viscosidad aconsejada para el aceite de lubricación</i> | Viscosidade aconselhável para o óleo de lubrificação |
| V_{ca} | [cm ³] | Volume minimum d'huile de commande d'ouverture du frein | <i>Volumen mín. de aceite mando apertura freno</i> | Min. volume de óleo comando abertura freio |
| M | [kg] | Masse | <i>Masa</i> | Massa |
| n_1 max | [min ⁻¹] | Max. tours en entrée | <i>Revoluciones máx. en entrada</i> | Max. Rotações em entrada |

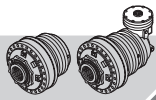

12 ACCOPPIAMENTI PER MOTORI IDRAULICI ED ELETTRICI

Nelle pagine seguenti sono riportati gli accoppiamenti disponibili per motori idraulici ed elettrici.

Per ciascun accoppiamento sono indicati il codice d'ordine e la quota **X** da sommare alla lunghezza del riduttore, in configurazione di ingresso standard, per ottenere l'ingombro totale.

È inoltre indicato il tipo di configurazione in ingresso richiesta sul riduttore (standard, predisposizione **RF** o predisposizione **BOC**) per consentire il montaggio dell'accoppiamento.

Nel caso di riduttori con predisposizione RF la lunghezza da considerare per il riduttore è sempre quella relativa al riduttore in configurazione standard.

Altri tipi di accoppiamenti sono disponibili a richiesta.

Esempio 1

Si vuole selezionare un accoppiamento per un motore idraulico con flangiatura SAE A 2 fori ed albero cilindrico da 25 mm su un riduttore RR510D MS.

Consultando la tabella degli accoppiamenti per motori idraulici si vede che l'accoppiamento richiesto è disponibile e può essere montato sul riduttore con ingresso in configurazione standard; il codice dell'accoppiamento è 154-2300M317, mentre la quota da sommare alla lunghezza del riduttore, che in questo caso è 251.5 mm, è X=25 mm.

L'ingombro totale sarà dunque pari a 251.5+25=276.5 mm.

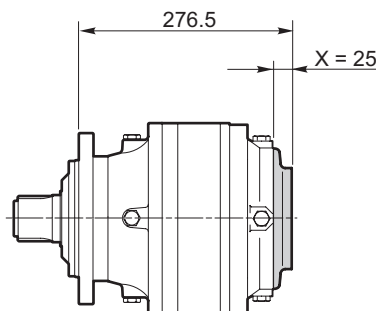

12 HYDRAULIC AND ELECTRIC MOTORS COUPLINGS

The couplings available for hydraulic and electric motors are given on the following pages.

The order code and value **X** are given for each coupling; this value has to be added to the length of the reduction gear (in the standard input configuration) to find the total dimension.

The type of input configuration required for the reduction gear is also indicated (standard, **RF** setup or **BOC** setup) so the coupling can be mounted.

For those reduction gears with RF setup, the length to consider for the reduction gear is always the length of the standard configuration reduction gear.

Other coupling types are available on request.

Example 1

You want to select a coupling for a hydraulic motor with a 2-hole SAE flanging and a 25 mm cylindrical shaft on an RR510D MS reduction gear.

If you look at the couplings table for hydraulic motors you will see that the coupling required is available and can be mounted on the reduction gear with a standard configuration input; the coupling code is 154-2300M317 while the value to add to the length of the reduction gear, which is 251.5 mm in this case, is X=25 mm. So we have a total dimension of 251.5+25=276.5 mm.

12 KUPPLUNGEN FÜR HYDRAULIK- MOTOREN UND ELEKTROMOTOREN

Auf den folgenden Seiten sind die für Hydraulikmotoren und Elektromotoren erhältlichen Kupplungen aufgelistet.

Für jede Kupplung sind die Bestellnummer und der Wert **X** angegeben, der zur Länge vom Planetengetriebe bei Konfiguration mit Standardeingang addiert werden muss, um den Gesamttraumbedarf zu ermitteln.

Außerdem ist die am Planetengetriebe erforderliche Eingangskonfiguration angegeben (Standard, ausgelegt auf RF oder ausgelegt auf **BOC**), um die Montage der Kupplung zu ermöglichen.

Bei Planetengetriebe, die auf **RF** ausgelegt sind, entspricht die Länge, die für das Planetengetriebe berücksichtigt werden muss, immer der des Planetengetriebes in der Standardkonfiguration.

Auf Wunsch sind auch andere Kupplungen erhältlich.

Beispiel 1

Es soll eine Kupplung für einen Hydraulikmotor mit Flansch SAE mit zwei Bohrungen und 25 mm Zylinderwelle auf einem Planetengetriebe RR510D MS ausgewählt werden.

Der Tabelle mit den Kupplungen für Hydraulikmotoren kann entnommen werden, dass die erforderliche Kupplung verfügbar ist und auf dem Planetengetriebe mit Eingang mit Standardkonfiguration montiert werden kann. Die Bestellnummer der Kupplung ist 154-2300M317, der Wert, der zur Länge vom Planetengetriebe (in diesem Fall 251.5 mm) addiert werden muss, beträgt X=25 mm. Für den Gesamttraumbedarf ergibt sich damit ein Wert von 251.5+25=276.5 mm.

| Code | SAE A 2B | | | | SAE | | | |
|--------|------------|------------|------------|------------|------|------|-------|-------|
| | 16 032 213 | 16 032 213 | 16 032 215 | 16 032 215 | ø78" | ø91" | ø114" | ø114" |
| RR110 | • | • | • | • | • | • | • | • |
| RR110D | • | • | • | • | • | • | • | • |
| RR110T | • | • | • | • | • | • | • | • |
| RA110 | • | • | • | • | • | • | • | • |
| RA110D | • | • | • | • | • | • | • | • |
| RR210 | • | • | • | • | • | • | • | • |
| RR210D | • | • | • | • | • | • | • | • |
| RR210T | • | • | • | • | • | • | • | • |
| RR210Q | • | • | • | • | • | • | • | • |
| RA210 | • | • | • | • | • | • | • | • |
| RA210D | • | • | • | • | • | • | • | • |
| RR310 | • | • | • | • | • | • | • | • |
| RR310D | • | • | • | • | • | • | • | • |
| RR310T | • | • | • | • | • | • | • | • |
| RR310Q | • | • | • | • | • | • | • | • |
| RR510 | • | • | • | • | • | • | • | • |
| RR510D | • | • | • | • | • | • | • | • |
| RR510T | • | • | • | • | • | • | • | • |
| RA510T | • | • | • | • | • | • | • | • |

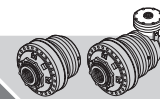

12 ACCOUPLEMENTS POUR MOTEURS HYDRAULIQUES ET ELECTRIQUES

Les accouplements existants pour les moteurs hydrauliques et électriques sont indiqués sur les pages suivantes.

A chaque accouplement correspond l'indication du code à utiliser au moment de la commande et la cote **X** à additionner à la longueur du réducteur, en configuration d'entrée standard, pour obtenir l'encombrement total.

Le type de configuration en entrée demandée sur le réducteur (standard, pré-réglage **RF** ou pré-réglage **BOC**) est aussi indiqué pour permettre le montage de l'accouplement.

Pour des réducteurs avec pré-réglage RF, la longueur à prendre en considération pour le réducteur est toujours la longueur relative au réducteur en configuration standard.

Il est possible d'obtenir d'autres types d'accouplement sur simple demande.

Exemple 1

Pour trouver un accouplement pour un moteur hydraulique avec bridage SAE à 2 trous et arbre cylindrique de 25 mm sur un réducteur RR510D MS, en consultant le tableau des accouplements pour moteurs hydraulique, on voit que l'accouplement demandé existe et peut être monté sur le réducteur avec entrée en configuration standard; le code de l'accouplement est 154-2300M317, alors que la cote à additionner à la longueur du réducteur, qui dans ce cas est de 251.5 mm, est X=25 mm. L'encombrement total sera donc de 251.5+25=276.5 mm.

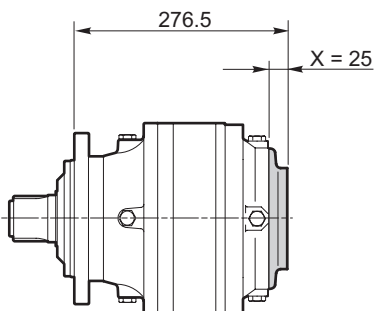

12 ACOPLAMIENTOS PARA MOTORES HIDRÁULICOS Y ELÉCTRICOS

En las páginas siguientes se presentan los acoplamiento disponibles para motores hidráulicos y eléctricos.

Para cada acoplamiento se indican el código de pedido y la cota **X** a sumar a la longitud del reductor, en configuración de entrada estándar, para obtener las medidas máximas totales.

Además se indica el tipo de configuración en entrada pedida en el reductor (estándar, predisposición **RF** o predisposición **BOC**) para consentir el montaje del acoplamiento.

En el caso de reductores con predisposición RF, la longitud a considerar para el reductor es siempre aquella relativa al reductor en configuración estándar.

Otros tipos de acoplamiento están disponibles a petición.

Ejemplo 1

Se desea seleccionar un acoplamiento para un motor hidráulico con brida SAE de 2 agujeros y eje cilíndrico de 25 mm en un reductor RR510D MS.

Consultando la tabla de los acoplamiento para motores hidráulicos podemos ver que el acoplamiento requerido está disponible y se puede montar en el reductor con entrada en configuración estándar; el código del acoplamiento es el 154-2300M317, mientras que la cota a sumar a la longitud del reductor, que en este caso es 251.5 mm, es X=25 mm. Las medidas máximas totales serán por lo tanto 251.5+25=276.5 mm.

12 ACOPLAGENS PARA MOTORES HIDRÁULICOS E ELÉTRICOS

Nas páginas seguintes estão indicadas as acoplagens disponíveis para motores hidráulicos e elétricos.

Para cada acoplamento estão indicados o código de encomenda e a cota **X** a somar ao comprimento do reductor, em configuração de entrada padrão, para obter a dimensão total.

Também está indicado o tipo de configuração em entrada necessária no reductor (padrão, predisposição **RF** ou predisposição **BOC**) para consentir a montagem da acoplamento.

No caso de reductores com predisposição RF o comprimento a considerar para o reductor é sempre aquele relativa ao reductor em configuração padrão.

Outros tipos de acoplamentos podem ser fornecidos a pedido.

Exemplo 1

Deseja-se selecionar uma acoplamento para um motor hidráulico com flange SAE de 2 furos e veio cilíndrico de 25 mm sobre um reductor RR510D MS.

Consultando a tabela das acoplamentos para motores hidráulicos pode-se ver que a acoplamento necessária é disponível e pode ser montada sobre o reductor com entrada em configuração padrão; o código da acoplamento é 154-2300M317, enquanto que a cota a somar ao comprimento do reductor, que neste caso é 251.5 mm, é X=25 mm. Portanto, a dimensão total será igual a 251.5+25=276.5 mm.

| Code | SAE A 2B | | | | | SAE | | | | |
|--------|------------|------------|------------|------------|------------|-------|-----|-----|---------|--|
| | 16 022 213 | 16 022 213 | 16 022 213 | 16 022 215 | 16 022 215 | ø7/8" | ø1" | ø1" | ø1 1/4" | |
| RR110 | • | • | • | • | • | • | • | • | • | |
| RR110D | • | • | • | • | • | • | • | • | • | |
| RR110T | • | • | • | • | • | • | • | • | • | |
| RA110 | • | • | • | • | • | • | • | • | • | |
| RA110D | • | • | • | • | • | • | • | • | • | |
| RR210 | • | • | • | • | • | • | • | • | • | |
| RR210D | • | • | • | • | • | • | • | • | • | |
| RR210T | • | • | • | • | • | • | • | • | • | |
| RR210Q | • | • | • | • | • | • | • | • | • | |
| RA210 | • | • | • | • | • | • | • | • | • | |
| RA210D | • | • | • | • | • | • | • | • | • | |
| RR310 | • | • | • | • | • | • | • | • | • | |
| RR310D | • | • | • | • | • | • | • | • | • | |
| RR310T | • | • | • | • | • | • | • | • | • | |
| RR310Q | • | • | • | • | • | • | • | • | • | |
| RR510 | • | • | • | • | • | • | • | • | • | |
| RR510D | • | • | • | • | • | • | • | • | • | |
| RR510T | • | • | • | • | • | • | • | • | • | |
| RA510T | • | • | • | • | • | • | • | • | • | |

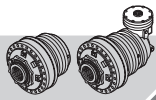

Esempio 2

Si vuole selezionare un accoppiamento per un motore idraulico con flangiatura SAE A 4 fori ed albero cilindrico da 1 pollice su un riduttore RR510D MS. Consultando la tabella degli accoppiamenti per motori idraulici si vede che l'accoppiamento richiesto è disponibile e può essere montato sul riduttore con ingresso predisposto RF; il codice dell'accoppiamento è 154-2300M560, mentre la quota da sommare alla lunghezza del riduttore, che in questo caso è 251.5 mm, è X=44 mm. L'ingombro totale sarà dunque pari a 251.5+44=295.5 mm.

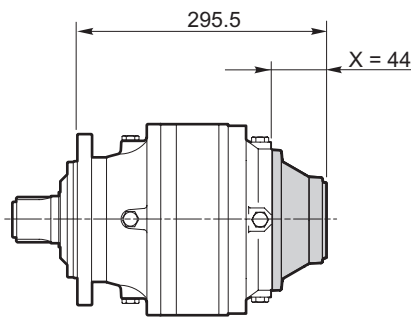

Example 2

You want to select a coupling for a hydraulic motor with a 4-hole SAE flanging and a 1 inch cylindrical shaft on an RR510D MS reduction gear. If you look at the couplings table for hydraulic motors you will see that the coupling required is available and can be mounted on the reduction gear with an RF setup input; the coupling code is 154-2300M560 while the value to add to the length of the reduction gear, which is 251.5 mm in this case, is X=44 mm. So we have a total dimension of 251.5+44=295.5 mm.

Beispiel 2

Es soll eine Kupplung für einen Hydraulikmotor mit Flansch SAE mit 4 Bohrungen und 1 Zoll Zylinderwelle auf einem Planetengetriebe RR510D MS ausgewählt werden. Der Tabelle mit den Kupplungen für Hydraulikmotoren kann entnommen werden, dass die erforderliche Kupplung verfügbar ist und auf dem Planetengetriebe mit einem auf RF ausgelegten Eingang montiert werden kann. Die Bestellnummer der Kupplung ist 154-2300M560, der Wert, der zur Länge v.m Planetengetriebe (in diesem Fall 251.5 mm) addiert werden muss, beträgt X=44 mm. Für den Gesamttraumbedarf ergibt sich damit ein Wert von 251.5+44=295.5 mm.

| Code | SAE | | | | | | | |
|--------|-----------------------|------------------------|------------------------|-----------------|------------------|------------------|-----------------|-------------------|
| | SAE A 3B 16/32 Z13 | SAE A 24B 16/32 Z13 | SAE A 24B 16/32 Z13 | SAE A 3B e25 | SAE A 24B Ø16 | SAE A 24B Ø16 | SAE A 3B Ø1" | SAE A 2/4B Ø1" |
| RR110 | 24 | 23 | 23 | 23 | 23 | 23 | 24 | 24 |
| RR110D | | | | | | | | |
| RR110T | | | | | | | | |
| RA110 | | | | | | | | |
| RA110D | | | | | | | | |
| RR210 | | | | | | | | |
| RR210D | | | | | | | | |
| RR210T | | | | | | | | |
| RR210Q | | | | | | | | |
| RA210 | | | | | | | | |
| RA210D | | | | | | | | |
| RR310 | | | | | | | | |
| RR310D | | | | | | | | |
| RR310T | | | | | | | | |
| RR310Q | | | | | | | | |
| RA510 | | | | | | | | |
| RA510D | | | | | | | | |
| RA510T | | | | | | | | |
| RA510Q | | | | | | | | |
| RR510 | | | | | | | | |
| RR510D | | | | | | | | |
| RR510T | | | | | | | | |
| RR510Q | | | | | | | | |
| RA310T | | | | | | | | |

Esempio 3

Si vuole selezionare un accoppiamento per un motore elettrico IEC grandezza 80 su un riduttore RA510 MS. Consultando la tabella degli accoppiamenti per motori elettrici si vede che l'accoppiamento richiesto è disponibile e può essere montato sul riduttore con ingresso in configurazione standard; il codice dell'accoppiamento è 154-2300M229, mentre la quota da sommare all'altezza del riduttore, che in questo caso è 247.5 mm, è X=24 mm. L'ingombro totale sarà dunque pari a 247.5+24=271.5 mm.

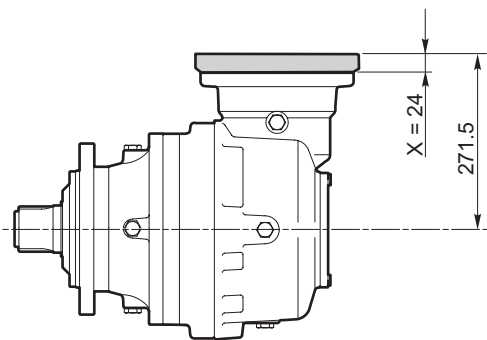

Example 3

You want to select a coupling for a size 80 IEC electric motor on an RA510 MS reduction gear. If you look at the couplings table for electric motors you will see that the coupling required is available and can be mounted on the reduction gear with a standard configuration input; the coupling code is 154-2300M229 while the value to add to the height of the reduction gear, which is 247.5 mm in this case, is X=24 mm. So we have a total dimension of 247.5+24=271.5 mm.

Beispiel 3

Es soll eine Kupplung für einen Elektromotor IEC mit einer Größe von 80 auf einem Planetengetriebe RA510 MS ausgewählt werden. Der Tabelle mit den Kupplungen für Elektromotoren kann entnommen werden, dass die erforderliche Kupplung verfügbar ist und auf dem Planetengetriebe mit Eingang mit Standardkonfiguration montiert werden kann. Die Bestellnummer der Kupplung ist 154-2300M229, der Wert, der zur Höhe vom Planetengetriebe (in diesem Fall 247.5 mm) addiert werden muss, beträgt X=24 mm. Für den Gesamttraumbedarf ergibt sich damit ein Wert von 247.5+24=271.5 mm.

| Code | IEC B5 | | | | | | | | | | | | |
|--------|--------|------|----|----|---------|-----|------|-----|-----|------|------|-----|-------|
| | 63 | 71 | 80 | 90 | 100-112 | 132 | 160 | 180 | 200 | 225 | 250 | 280 | |
| RR110 | 24 | 18.5 | 18 | 24 | 32.5 | 30 | 32.5 | 52 | 97 | 62.5 | 75.5 | 128 | 104.8 |
| RR110D | | | | | | | | | | | | | |
| RR110T | | | | | | | | | | | | | |
| RA110 | | | | | | | | | | | | | |
| RA110D | | | | | | | | | | | | | |
| RR210 | | | | | | | | | | | | | |
| RR210D | | | | | | | | | | | | | |
| RR210T | | | | | | | | | | | | | |
| RR210Q | | | | | | | | | | | | | |
| RA210 | | | | | | | | | | | | | |
| RA210D | | | | | | | | | | | | | |
| RR310 | | | | | | | | | | | | | |
| RR310D | | | | | | | | | | | | | |
| RR310T | | | | | | | | | | | | | |
| RR310Q | | | | | | | | | | | | | |
| RA310 | | | | | | | | | | | | | |
| RA310D | | | | | | | | | | | | | |
| RA310T | | | | | | | | | | | | | |
| RA310Q | | | | | | | | | | | | | |
| RR510Q | | | | | | | | | | | | | |
| RA510 | | | | | | | | | | | | | |
| RA510D | | | | | | | | | | | | | |

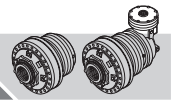

Exemple 2

Pour choisir un accouplement pour un moteur hydraulique avec bridage SAE à 4 trous et arbre cylindrique d'1 pouce sur un réducteur RR510D MS, consulter le tableau des accouplements pour moteurs hydrauliques, on voit que l'accouplement demandé existe et peut être monté sur le réducteur avec entrée préréglé RF; le code de l'accouplement est 154-2300M560, alors que la cote à additionner à la longueur du réducteur, qui dans ce cas est de 251.5 mm, est X=44 mm. L'encombrement total sera donc de 251.5+44=295.5 mm.

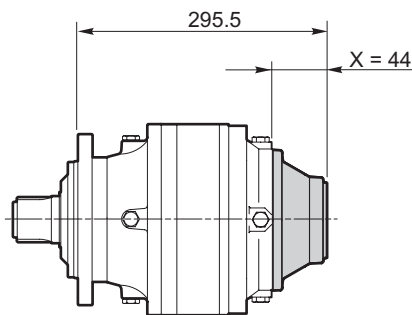

Ejemplo 2

Se desea seleccionar un acoplamiento para un motor hidráulico con brida SAE de 4 agujeros y eje cilíndrico de 1 pulgada en un reductor RR510D MS. Consultando la tabla de los acoplamientos para motores hidráulicos podemos ver que el acoplamiento requerido está disponible y se puede montar en el reductor con entrada predispuesta RF; el código del acoplamiento es el 154-2300M560, mientras que la cota a sumar a la longitud del reductor, que en este caso es 251.5 mm, es X=44 mm. Las medidas máximas totales serán por lo tanto 251.5+44=295.5 mm.

Exemplo 2

Deseja-se selecionar uma acoplagem para um motor hidráulico com flange SAE de 4 furos e veio cilíndrico de 1 polegada sobre um redutor RR510D MS. Consultando a tabela das acoplagens para motores hidráulicos pode-se ver que a acoplagem necessária é disponível e pode ser montada no redutor com entrada predisposta RF; o código da acoplagem é 154-2300M560, enquanto que a cota a somar ao comprimento do redutor, que neste caso é 251.5 mm, é X=44 mm. Portanto, a dimensão total será igual a 251.5+44=295.5 mm.

| Code | SAE | | | | | | | | SAE A 2/4B ø1" |
|--------|---|---|---|---|---|---|---|---|-------------------|
| | 154-2300M267 SAE A 2/4B 16/32 213 | 154-2300M574 SAE A 2/4B 16/32 213 | 154-2300M563 SAE A 2/4B 16/32 213 | 154-2300M575 SAE A 2/4B 16/32 213 | 154-2300M594 SAE A 2/4B 16/32 213 | 154-2300M317 SAE A 2/4B 16/32 213 | 154-2300M573 SAE A 2/4B 16/32 213 | 154-2300M592 SAE A 2/4B 16/32 213 | |
| RR110 | • | • | • | • | • | • | • | • | • |
| RR110D | • | • | • | • | • | • | • | • | • |
| RR110T | • | • | • | • | • | • | • | • | • |
| RA110 | • | • | • | • | • | • | • | • | • |
| RA110D | • | • | • | • | • | • | • | • | • |
| RR210 | • | • | • | • | • | • | • | • | • |
| RR210D | • | • | • | • | • | • | • | • | • |
| RR210T | • | • | • | • | • | • | • | • | • |
| RR210Q | • | • | • | • | • | • | • | • | • |
| RA210 | • | • | • | • | • | • | • | • | • |
| RA210D | • | • | • | • | • | • | • | • | • |
| RR310 | • | • | • | • | • | • | • | • | • |
| RR310D | • | • | • | • | • | • | • | • | • |
| RR310T | • | • | • | • | • | • | • | • | • |
| RR310Q | • | • | • | • | • | • | • | • | • |
| RA310 | • | • | • | • | • | • | • | • | • |
| RA310D | • | • | • | • | • | • | • | • | • |
| RA310T | • | • | • | • | • | • | • | • | • |
| RA310Q | • | • | • | • | • | • | • | • | • |
| RR510 | • | • | • | • | • | • | • | • | • |
| RR510D | • | • | • | • | • | • | • | • | • |
| RR510T | • | • | • | • | • | • | • | • | • |
| RR510Q | • | • | • | • | • | • | • | • | • |
| RA510 | • | • | • | • | • | • | • | • | • |
| RA510D | • | • | • | • | • | • | • | • | • |
| RA510T | • | • | • | • | • | • | • | • | • |
| RA510Q | • | • | • | • | • | • | • | • | • |

Exemple 3

Pour choisir un accouplement pour un moteur électrique IEC grandeur 80 sur un réducteur RA510 MS, consulter le tableau des accouplements pour moteurs électriques, on voit que l'accouplement demandé existe et peut être monté sur le réducteur avec entrée en configuration standard; le code de l'accouplement est 154-2300M229, alors que la cote à additionner à la hauteur du réducteur, qui dans ce cas est de 247.5 mm, est X=24 mm. L'encombrement total sera donc de 247.5+24=271.5 mm.

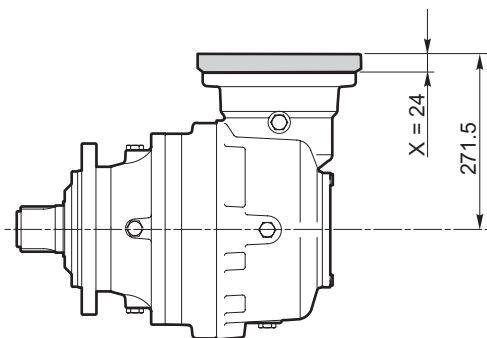

Ejemplo 3

Se desea seleccionar un acoplamiento para un motor eléctrico IEC talla 80 en un reductor RA510 MS. Consultando la tabla de los acoplamientos para motores eléctricos podemos ver que el acoplamiento requerido está disponible y se puede montar en el reductor con entrada en configuración estándar; el código del acoplamiento es el 154-2300M229, mientras que la cota a sumar a la altura del reductor, que en este caso es 247.5 mm, es X=24 mm. Las medidas máximas totales serán por lo tanto 247.5+24=271.5 mm.

Exemplo 3

Deseja-se selecionar uma acoplagem para um motor elétrico IEC grandeza 80 sobre um redutor RA510 MS. Consultando a tabela das acoplagens para motores elétricos pode-se ver que a acoplagem necessária é disponível e pode ser montada no redutor com entrada em configuração padrão; o código da acoplagem é 154-2300M229, enquanto que a cota a somar à altura do redutor, que neste caso é 247.5 mm, é X=24 mm. Portanto, a dimensão total será igual a 247.5+24=271.5 mm.

| Code | IEC B5 | | | | | | | | | | | | |
|--------|--------|----|----|----|---------|-----|-----|-----|-----|-----|-----|-----|---|
| | 63 | 71 | 80 | 90 | 100-112 | 132 | 160 | 180 | 200 | 250 | 315 | 400 | |
| RR110 | • | • | • | • | • | • | • | • | • | • | • | • | • |
| RR110D | • | • | • | • | • | • | • | • | • | • | • | • | • |
| RR110T | • | • | • | • | • | • | • | • | • | • | • | • | • |
| RA110 | • | • | • | • | • | • | • | • | • | • | • | • | • |
| RA110D | • | • | • | • | • | • | • | • | • | • | • | • | • |
| RR210 | • | • | • | • | • | • | • | • | • | • | • | • | • |
| RR210D | • | • | • | • | • | • | • | • | • | • | • | • | • |
| RR210T | • | • | • | • | • | • | • | • | • | • | • | • | • |
| RR210Q | • | • | • | • | • | • | • | • | • | • | • | • | • |
| RA210 | • | • | • | • | • | • | • | • | • | • | • | • | • |
| RA210D | • | • | • | • | • | • | • | • | • | • | • | • | • |
| RR310 | • | • | • | • | • | • | • | • | • | • | • | • | • |
| RR310D | • | • | • | • | • | • | • | • | • | • | • | • | • |
| RR310T | • | • | • | • | • | • | • | • | • | • | • | • | • |
| RR310Q | • | • | • | • | • | • | • | • | • | • | • | • | • |
| RA310 | • | • | • | • | • | • | • | • | • | • | • | • | • |
| RA310D | • | • | • | • | • | • | • | • | • | • | • | • | • |
| RA310T | • | • | • | • | • | • | • | • | • | • | • | • | • |
| RA310Q | • | • | • | • | • | • | • | • | • | • | • | • | • |
| RR510 | • | • | • | • | • | • | • | • | • | • | • | • | • |
| RR510D | • | • | • | • | • | • | • | • | • | • | • | • | • |
| RR510T | • | • | • | • | • | • | • | • | • | • | • | • | • |
| RR510Q | • | • | • | • | • | • | • | • | • | • | • | • | • |
| RA510 | • | • | • | • | • | • | • | • | • | • | • | • | • |
| RA510D | • | • | • | • | • | • | • | • | • | • | • | • | • |
| RA510T | • | • | • | • | • | • | • | • | • | • | • | • | • |
| RA510Q | • | • | • | • | • | • | • | • | • | • | • | • | • |

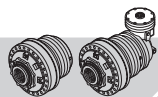

| Code | SAE | | | | | | | | | | | | | | | |
|------------------|-----------------------|-------------------------|-------------------------|-----------------|---------------------|-----------------|-------------------|---------------------|-------------------|---------------------|--------------|--------------|--------------|--------------|----------|----------|
| | SAE A 2B 16/32 z13 | SAE A 2/4B 16/32 z13 | SAE A 2/4B 16/32 z15 | SAE A 2B ø25 | SAE A 2/4B ø7/8" | SAE A 2B ø1" | SAE A 2/4B ø1" | SAE A 2B ø1 1/4" | SAE A 2B 1" 6B | SAE A 2/4B 1" 6B | | | | | | |
| | 154-2300M267 | 154-2300M574 | 154-2300M563 | 154-2300M575 | 154-2300M564 | 154-2300M317 | 154-2300M573 | 154-2300M562 | 154-2300M315 | 154-2300M571 | 154-2300M560 | 154-2300M269 | 154-2300M377 | 154-2300M272 | 154B2702 | 154B2700 |
| X | 24 | 23 | 44 | 23 | 44 | 25 | 23 | 44 | 25 | 23 | 44 | 24 | 37 | 24 | 23 | 44 |
| RR65 | | | | | | | | | | | | | | | | |
| RR65D | | | | | | | | | | | | | | | | |
| RR65T | | | | | | | | | | | | | | | | |
| RR105 | • | ■ | | ■ | | • | ■ | | • | ■ | | • | | • | ■ | |
| RR105D | | | | | | | | | | | | | | | | |
| RR105T | | | | | | | | | | | | | | | | |
| RA105 | • | | | | | • | | | • | | | • | | • | | |
| RA105D | • | | | | | • | | | • | | | • | | • | | |
| RR110 | • | ■ | | ■ | | • | ■ | | • | ■ | | • | | • | ■ | |
| RR110D | | | | | | | | | | | | | | | | |
| RR110T | | | | | | | | | | | | | | | | |
| RA110 | • | | | | | • | | | • | | | • | | • | | |
| RA110D | • | | | | | • | | | • | | | • | | • | | |
| RR210 | • | ■ | | ■ | | • | ■ | | • | ■ | | • | | • | ■ | |
| RR210D | • | ■ | | ■ | | • | ■ | | • | ■ | | • | | • | ■ | |
| RR210T | | | | | | | | | | | | | | | | |
| RR210Q | | | | | | | | | | | | | | | | |
| RA210 | • | | | | | • | | | • | | | • | | • | | |
| RA210D | • | | | | | • | | | • | | | • | | • | | |
| RR310 | • | ■ | ■ | ■ | ■ | • | ■ | ■ | • | ■ | ■ | • | ■ | • | ■ | ■ |
| RR310D | • | ■ | ■ | ■ | ■ | • | ■ | ■ | • | ■ | ■ | • | ■ | • | ■ | ■ |
| RR310T | | | | | | | | | | | | | | | | |
| RR310Q | | | | | | | | | | | | | | | | |
| RA310 | • | | | | | • | | | • | | | • | | • | | |
| RA310D | • | | | | | • | | | • | | | • | | • | | |
| RA310T | • | | | | | • | | | • | | | • | | • | | |
| RR510 | • | ■ | ■ | ■ | ■ | • | ■ | ■ | • | ■ | ■ | • | ■ | • | ■ | ■ |
| RR510D | • | ■ | ■ | ■ | ■ | • | ■ | ■ | • | ■ | ■ | • | ■ | • | ■ | ■ |
| RR510T | • | ■ | ■ | ■ | ■ | • | ■ | ■ | • | ■ | ■ | • | ■ | • | ■ | ■ |
| RR510Q | | | | | | | | | | | | | | | | |
| RA510 | • | | | | | • | | | • | | | • | | • | | |
| RA510D | • | | | | | • | | | • | | | • | | • | | |
| RA510T | • | | | | | • | | | • | | | • | | • | | |
| RR710 | • | ■ | ■ | ■ | ■ | • | ■ | ■ | • | ■ | ■ | • | ■ | • | ■ | ■ |
| RR710D | • | ■ | ■ | ■ | ■ | • | ■ | ■ | • | ■ | ■ | • | ■ | • | ■ | ■ |
| RR710T | • | ■ | ■ | ■ | ■ | • | ■ | ■ | • | ■ | ■ | • | ■ | • | ■ | ■ |
| RR710Q | | | | | | | | | | | | | | | | |
| RA710 | • | | | | | • | | | • | | | • | | • | | |
| RA710D | • | | | | | • | | | • | | | • | | • | | |
| RA710T | • | | | | | • | | | • | | | • | | • | | |
| RR810 | • 1) | | | | | • 1) | | | • 1) | | | • 1) | | • 1) | | |
| RR810D | • | ■ | ■ | ■ | ■ | • | ■ | ■ | • | ■ | ■ | • | ■ | • | ■ | ■ |
| RR810T | • | ■ | ■ | ■ | ■ | • | ■ | ■ | • | ■ | ■ | • | ■ | • | ■ | ■ |
| RR810Q | | | | | | | | | | | | | | | | |
| RA810 | • | | | | | • | | | • | | | • | | • | | |
| RA810D | • | | | | | • | | | • | | | • | | • | | |
| RA810T | • | | | | | • | | | • | | | • | | • | | |
| RR1010 | • 1) | | | | | • 1) | | | • 1) | | | • 1) | | • 1) | | |
| RR1010D | • | ■ | ■ | ■ | ■ | • | ■ | ■ | • | ■ | ■ | • | ■ | • | ■ | ■ |
| RR1010T | • | ■ | ■ | ■ | ■ | • | ■ | ■ | • | ■ | ■ | • | ■ | • | ■ | ■ |
| RR1010Q | • | ■ | ■ | ■ | ■ | • | ■ | ■ | • | ■ | ■ | • | ■ | • | ■ | ■ |
| RA1010 (A) | • | | | | | • | | | • | | | • | | • | | |
| RA1010 (B) | • 1) | | | | | • 1) | | | • 1) | | | • 1) | | • 1) | | |
| RA1010D | • | | | | | • | | | • | | | • | | • | | |
| RA1010T | • | | | | | • | | | • | | | • | | • | | |
| RR1700 | • 1) | | | | | • 1) | | | • 1) | | | • 1) | | • 1) | | |
| RR1700D | • | ■ | ■ | ■ | ■ | • | ■ | ■ | • | ■ | ■ | • | ■ | • | ■ | ■ |
| RR1700T | • | ■ | ■ | ■ | ■ | • | ■ | ■ | • | ■ | ■ | • | ■ | • | ■ | ■ |
| RR1700Q | • | ■ | ■ | ■ | ■ | • | ■ | ■ | • | ■ | ■ | • | ■ | • | ■ | ■ |
| RA1700 (A) | • | | | | | • | | | • | | | • | | • | | |
| RA1700 (B) | • 1) | | | | | • 1) | | | • 1) | | | • 1) | | • 1) | | |
| RA1700D | • | | | | | • | | | • | | | • | | • | | |
| RA1700T | • | | | | | • | | | • | | | • | | • | | |
| RF2/... CFG2 "A" | | | | | | | | | | | | | | | | |
| RF2/... CFG2 "B" | • | | | | | • | | | • | | | • | | • | | |
| RF5/...-RFF5/... | • | | | | | • | | | • | | | • | | • | | |
| RF170±290 | • 1) | | | | | • 1) | | | • 1) | | | • 1) | | • 1) | | |

- Ingresso standard / Standard input / Standardeingang / Entrée standard / Entrada standard / Entrada padrão (—)
 - Predisposizione RF / RF Setup / Auslegung RF / Préréglage RF / Predisposición RF / Predisposição RF
 - Predisposizione BOC / BOC Setup / Auslegung BOC / Préréglage BOC / Predisposición BOC / Predisposição BOC
- 1) Con / With / Mit / Avec / Con / Com **KIT CB01**



| | SAE | | | | | | | | | | | | | | | | | |
|------------------|-----------------------|--------------|-------------------------|--------------|-----------------------|--------------|-------------------------|--------------|-------------------|---------------------|--------------|-----------------|-------------------|--------------|---------------------|---------------------|----------|----------|
| | SAE B 2B 16/32 z13 | | SAE B 2/4B 16/32 z13 | | SAE B 2B 16/32 z15 | | SAE B 2/4B 16/32 z15 | | SAE B 2B ø7/8" | SAE B 2/4B ø7/8" | | SAE B 2B ø1" | SAE B 2/4B ø1" | | SAE B 2B ø1 1/4" | SAE B 2/4B 1" 6B | | |
| | Code | 154-2300M358 | 154-2300M284 | 154-2300M579 | 154-2300M568 | 154-2300M295 | 154-2300M283 | 154-2300M580 | 154-2300M569 | 154-2300M290 | 154-2300M578 | 154-2300M567 | 154-2300M285 | 154-2300M576 | 154-2300M565 | 154-2300M286 | 154B2703 | 154B2701 |
| X | 30 | 24 | 23 | 44 | 30 | 24 | 23 | 44 | 24 | 23 | 44 | 24 | 23 | 44 | 24 | 23 | 44 | |
| RR65 | . | | | | . | | | | | | | | | | | | | |
| RR65D | . | | | | . | | | | | | | | | | | | | |
| RR65T | . | | | | . | | | | | | | | | | | | | |
| RR105 | | . | ■ | | | | ■ | | . | | ■ | | . | ■ | | . | ■ | |
| RR105D | . | | | | . | | | | . | | | | . | | | . | | |
| RR105T | . | | | | . | | | | . | | | | . | | | . | | |
| RA105 | | . | | | | . | | | . | | | | . | | | . | | |
| RA105D | | . | | | | . | | | . | | | | . | | | . | | |
| RR110 | | . | ■ | | | . | ■ | | . | | ■ | | . | ■ | | . | ■ | |
| RR110D | . | | | | . | | | | . | | | | . | | | . | | |
| RR110T | . | | | | . | | | | . | | | | . | | | . | | |
| RA110 | | . | | | | . | | | . | | | | . | | | . | | |
| RA110D | | . | | | | . | | | . | | | | . | | | . | | |
| RR210 | | . | ■ | | | . | ■ | | . | | ■ | | . | ■ | | . | ■ | |
| RR210D | | . | | | | . | | | . | | | | . | | | . | | |
| RR210T | . | | | | . | | | | . | | | | . | | | . | | |
| RR210Q | . | | | | . | | | | . | | | | . | | | . | | |
| RA210 | | . | | | | . | | | . | | | | . | | | . | | |
| RA210D | | . | | | | . | | | . | | | | . | | | . | | |
| RR310 | | . | ■ | | | . | ■ | | . | | ■ | | . | ■ | | . | ■ | |
| RR310D | . | . | | | . | | | | . | | | | . | | | . | | |
| RR310T | . | | | | . | | | | . | | | | . | | | . | | |
| RR310Q | . | | | | . | | | | . | | | | . | | | . | | |
| RA310 | | . | | | | . | | | . | | | | . | | | . | | |
| RA310D | | . | | | | . | | | . | | | | . | | | . | | |
| RA310T | | . | | | | . | | | . | | | | . | | | . | | |
| RR510 | | . | ■ | | | . | ■ | | . | | ■ | | . | ■ | | . | ■ | |
| RR510D | | . | | | | . | | | . | | | | . | | | . | | |
| RR510T | | . | ■ | | | . | ■ | | . | | ■ | | . | ■ | | . | ■ | |
| RR510Q | . | | | | | . | | | . | | | | . | | | . | | |
| RA510 | | . | | | | . | | | . | | | | . | | | . | | |
| RA510D | | . | | | | . | | | . | | | | . | | | . | | |
| RA510T | | . | | | | . | | | . | | | | . | | | . | | |
| RR710 | | . | ■ | | | . | ■ | | . | | ■ | | . | ■ | | . | ■ | |
| RR710D | | . | | | | . | | | . | | | | . | | | . | | |
| RR710T | | . | ■ | | | . | ■ | | . | | ■ | | . | ■ | | . | ■ | |
| RR710Q | . | | | | | . | | | . | | | | . | | | . | | |
| RA710 | | . | | | | . | | | . | | | | . | | | . | | |
| RA710D | | . | | | | . | | | . | | | | . | | | . | | |
| RA710T | | . | | | | . | | | . | | | | . | | | . | | |
| RR810 | | ◦1) | | | | ◦1) | | | ◦1) | | | | ◦1) | | | ◦1) | | |
| RR810D | | . | | | | . | | | . | | | | . | | | . | | |
| RR810T | | . | ■ | | | . | ■ | | . | | ■ | | . | ■ | | . | ■ | |
| RR810Q | . | | | | | . | | | . | | | | . | | | . | | |
| RA810 | | . | | | | . | | | . | | | | . | | | . | | |
| RA810D | | . | | | | . | | | . | | | | . | | | . | | |
| RA810T | | . | | | | . | | | . | | | | . | | | . | | |
| RR1010 | | ◦1) | | | | ◦1) | | | ◦1) | | | | ◦1) | | | ◦1) | | |
| RR1010D | | . | | | | . | | | . | | | | . | | | . | | |
| RR1010T | | . | ■ | | | . | ■ | | . | | ■ | | . | ■ | | . | ■ | |
| RR1010Q | | . | | | | . | | | . | | | | . | | | . | | |
| RA1010 (A) | | . | | | | . | | | . | | | | . | | | . | | |
| RA1010 (B) | | ◦1) | | | | ◦1) | | | ◦1) | | | | ◦1) | | | ◦1) | | |
| RA1010D | | . | | | | . | | | . | | | | . | | | . | | |
| RA1010T | | . | | | | . | | | . | | | | . | | | . | | |
| RR1700 | | ◦1) | | | | ◦1) | | | ◦1) | | | | ◦1) | | | ◦1) | | |
| RR1700D | | . | | | | . | | | . | | | | . | | | . | | |
| RR1700T | | . | | | | . | | | . | | | | . | | | . | | |
| RR1700Q | | . | ■ | | | . | ■ | | . | | ■ | | . | ■ | | . | ■ | |
| RA1700 (A) | | . | | | | . | | | . | | | | . | | | . | | |
| RA1700 (B) | | ◦1) | | | | ◦1) | | | ◦1) | | | | ◦1) | | | ◦1) | | |
| RA1700D | | . | | | | . | | | . | | | | . | | | . | | |
| RA1700T | | . | | | | . | | | . | | | | . | | | . | | |
| RF2/... CFG2 "A" | . | | | | . | | | | . | | | | . | | | . | | |
| RF2/... CFG2 "B" | | . | | | | . | | | . | | | | . | | | . | | |
| RF5/...-RFF5/... | | . | | | | . | | | . | | | | . | | | . | | |
| RF170±290 | | ◦1) | | | | ◦1) | | | ◦1) | | | | ◦1) | | | ◦1) | | |

- Ingresso standard / Standard input / Standardeingang / Entrée standard / Entrada standard / Entrada padrão (→)
 - Predisposizione RF / RF Setup / Auslegung RF / Préréglage RF / Predisposición RF / Predisposição RF
 - Predisposizione BOC / BOC Setup / Auslegung BOC / Préréglage BOC / Predisposición BOC / Predisposição BOC
- 1) Con / With / Mit / Avec / Con / Com **KIT CB01**

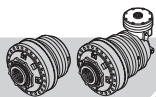

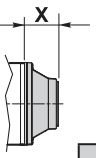
|  | SAE | | | | | | | | | | | | | | |
|---|------|-------------------------|--------------|--------------|-------------------------|-------------------------|-------------------------|-----------------------|-----------------------|-----------------------|----------------------|----------------------|----------------------|--------------|--------------|
| | | SAE C 2/4B 12/24 z14 | | | SAE C 2/4B 12/24 z17 | SAE C 2/4B 16/32 z21 | SAE C 2/4B 16/32 z23 | SAE C 4B 16/32 z23 | SAE C 2/4B ø1 1/4" | SAE D 4B 16/32 z27 | SAE D 4B 8/16 z13 | SAE E 4B 8/16 z13 | SAE E 4B 8/16 z15 | | |
| | Code | 154-2300M302 | 154-2300M570 | 154-2300M408 | 154-2300M304 | 154-2300M300 | 154-2300M299 | 154-2300M305 | 154-2300M303 | 154-2300M394 | 154-2300M306 | 154-2300M464 | 154-2300M396 | 154-2300M310 | 154-2300M629 |
| X | 31.5 | 46 | 46.5 | 31.5 | 31.5 | 31.5 | 46.5 | 31.5 | 124 | 70 | 108 | 70 | 74 | 112 | |
| RR65 | | | | | | | | | | | | | | | |
| RR65D | | | | | | | | | | | | | | | |
| RR65T | | | | | | | | | | | | | | | |
| RR105 | • | | | • | • | • | | • | • | | • | | | | • |
| RR105D | | | | | | | | | | | | | | | |
| RR105T | | | | | | | | | | | | | | | |
| RA105 | • | | | • | • | • | | • | • | | • | | | | • |
| RA105D | • | | | • | • | • | | • | • | | • | | | | • |
| RR110 | • | | | • | • | • | | • | • | | • | | | | • |
| RR110D | | | | | | | | | | | | | | | |
| RR110T | | | | | | | | | | | | | | | |
| RA110 | • | | | • | • | • | | • | • | | • | | | | • |
| RA110D | • | | | • | • | • | | • | • | | • | | | | • |
| RR210 | • | | | • | • | • | | • | • | | • | | | | • |
| RR210D | • | | | • | • | • | | • | • | | • | | | | • |
| RR210T | | | | | | | | | | | | | | | |
| RR210Q | | | | | | | | | | | | | | | |
| RA210 | • | | | • | • | • | | • | • | | • | | | | • |
| RA210D | • | | | • | • | • | | • | • | | • | | | | • |
| RR310 | | ■ | | • | • | • | | • | • | | • | | ○ | | • |
| RR310D | • | | | • | • | • | | • | • | | • | | | | • |
| RR310T | | | | | | | | | | | | | | | |
| RR310Q | | | | | | | | | | | | | | | |
| RA310 | • | | | • | • | • | | • | • | | • | | | | • |
| RA310D | • | | | • | • | • | | • | • | | • | | | | • |
| RA310T | • | | | • | • | • | | • | • | | • | | | | • |
| RR510 | | ■ | | • | • | • | | • | • | | • | | ○ | | • |
| RR510D | | ■ | | • | • | • | | • | • | | • | | ○ | | • |
| RR510T | • | | | • | • | • | | • | • | | • | | | | • |
| RR510Q | | | | | | | | | | | | | | | |
| RA510 | • | | | • | • | • | | • | • | | • | | | | • |
| RA510D | • | | | • | • | • | | • | • | | • | | | | • |
| RA510T | • | | | • | • | • | | • | • | | • | | | | • |
| RR710 | | ■ | | • | • | • | | • | • | | • | | ○ | | • |
| RR710D | | ■ | | • | • | • | | • | • | | • | | ○ | | • |
| RR710T | • | | | • | • | • | | • | • | | • | | | | • |
| RR710Q | | | | | | | | | | | | | | | |
| RA710 | • | | | • | • | • | | • | • | | • | | | | • |
| RA710D | • | | | • | • | • | | • | • | | • | | | | • |
| RA710T | • | | | • | • | • | | • | • | | • | | | | • |
| RR810 | | | • | •1) | •1) | •1) | • | •1) | | • | | • | | | •1) |
| RR810D | | ■ | | • | • | • | | • | • | | • | | ○ | | • |
| RR810T | • | | | • | • | • | | • | • | | • | | | | • |
| RR810Q | | | | | | | | | | | | | | | |
| RA810 | • | | | • | • | • | | • | • | | • | | | | • |
| RA810D | • | | | • | • | • | | • | • | | • | | | | • |
| RA810T | • | | | • | • | • | | • | • | | • | | | | • |
| RR1010 | | | • | •1) | •1) | •1) | • | •1) | | • | | • | | | •1) |
| RR1010D | | ■ | | • | • | • | | • | • | | • | | ○ | | • |
| RR1010T | | ■ | | • | • | • | | • | • | | • | | ○ | | • |
| RR1010Q | • | | | • | • | • | | • | • | | • | | | | • |
| RA1010 (A) | • | | | • | • | • | | • | • | | • | | | | • |
| RA1010 (B) | | | • | •1) | •1) | •1) | • | •1) | | • | | • | | | •1) |
| RA1010D | • | | | • | • | • | | • | • | | • | | | | • |
| RA1010T | • | | | • | • | • | | • | • | | • | | | | • |
| RR1700 | | | • | •1) | •1) | •1) | • | •1) | | • | | • | | | •1) |
| RR1700D | | ■ | | • | • | • | | • | • | | • | | ○ | | • |
| RR1700T | | ■ | | • | • | • | | • | • | | • | | ○ | | • |
| RR1700Q | • | | | • | • | • | | • | • | | • | | | | • |
| RA1700 (A) | • | | | • | • | • | | • | • | | • | | | | • |
| RA1700 (B) | | | • | •1) | •1) | •1) | • | •1) | | • | | • | | | •1) |
| RA1700D | • | | | • | • | • | | • | • | | • | | | | • |
| RA1700T | • | | | • | • | • | | • | • | | • | | | | • |
| RF2/... CFG2 "A" | | | | | | | | | | | | | | | |
| RF2/... CFG2 "B" | • | | | • | • | • | | • | • | | • | | | | • |
| RF5/...-RFF5/... | • | | | • | • | • | | • | • | | • | | | | • |
| RF170=290 | | | • | •1) | •1) | •1) | • | •1) | | • | | • | | | •1) |

- Ingresso standard / Standard input / Standardeingang / Entrée standard / Entrada standard / Entrada padrão (—)
 - Predisposizione RF / RF Setup / Auslegung RF / Préréglage RF / Predisposición RF / Predisposição RF
 - Predisposizione BOC / BOC Setup / Auslegung BOC / Préréglage BOC / Predisposición BOC / Predisposição BOC
- 1) Con / With / Mit / Avec / Con / Com **KIT CB01**

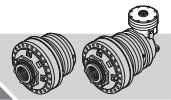

| | SAUER DANFOSS | | | | | | | | | | | | | | | | | | | |
|------------------|---------------|----------|-----------------------------|----------|----------------|----------|----------------|----------|----------------|----------|--------------------|--------------|------------------|----------|----------|----------|------------------------|----------|----------|----------|
| | OMM ø16 | | OMM 17x14 z9 DIN 5482 | | OMP-OMR ø25 | | OMP-OMR ø32 | | OMP-OMR ø1" | | OMP-OMR ø1 1/4" | | OMP-OMR 1" 6B | | | | | | | |
| | Code | 154-2594 | 154-5975 | 154-5976 | 154-5977 | 154B2704 | 154B2706 | 154-5980 | 154B2708 | 154B2709 | 154-5978 | 154-2300M571 | 154B2707 | 154-5981 | 154B2711 | 154B2710 | 154-3284 + 154-3285 | 154-5979 | 154B2702 | 154B2700 |
| X | 20.5 | 26.5 | 26.5 | 25 | 23 | 44 | 41.5 | 57 | 36 | 25 | 23 | 44 | 25 | 36 | 57 | 37 | 25 | 23 | 44 | |
| RR65 | • | | | | | | | | | | | | | | | • | | | | |
| RR65D | • | | | | | | | | | | | | | | | • | | | | |
| RR65T | • | | | | | | | | | | | | | | | • | | | | |
| RR105 | | • | • | | | ■ | | | ■ | | | | | | ■ | | | | | |
| RR105D | • | | | | | | | | | | | | | | | • | | | ■ | |
| RR105T | • | | | | | | | | | | | | | | | • | | | | |
| RA105 | | • | • | • | | | • | | | • | | | • | | | | • | | | |
| RA105D | | • | • | • | | | • | | | • | | | • | | | | • | | | |
| RR110 | | • | • | | | ■ | | | ■ | | | ■ | | | ■ | | | | ■ | |
| RR110D | • | | | | | | | | | | | | | | | • | | | | |
| RR110T | • | | | | | | | | | | | | | | | • | | | | |
| RA110 | | • | • | • | | | • | | | • | | | • | | | | • | | | |
| RA110D | | • | • | • | | | • | | | • | | | • | | | | • | | | |
| RR210 | | • | • | | | ■ | | | ■ | | | ■ | | | ■ | | | | ■ | |
| RR210D | | • | • | | | | | | | | | | | | | | | | | ■ |
| RR210T | • | | | | | | | | | | | | | | | | | | | |
| RR210Q | • | | | | | | | | | | | | | | | | | | | |
| RA210 | | • | • | • | | | • | | | • | | | • | | | | • | | | |
| RA210D | | • | • | • | | | • | | | • | | | • | | | | • | | | |
| RR310 | | • | • | | | ■ | ■ | | ■ | | | ■ | ■ | | ■ | | | | ■ | ■ |
| RR310D | | • | • | | | | | | | | | | | | | | | | | ■ |
| RR310T | • | | | | | | | | | | | | | | | | | | | |
| RR310Q | • | | | | | | | | | | | | | | | | | | | |
| RA310 | | • | • | • | | | • | | | • | | | • | | | | • | | | |
| RA310D | | • | • | • | | | • | | | • | | | • | | | | • | | | |
| RA310T | | • | • | • | | | • | | | • | | | • | | | | • | | | |
| RR510 | | • | • | | | ■ | | ■ | ■ | | | ■ | | | ■ | | | | ■ | ■ |
| RR510D | | • | • | | | | | | | | | | | | | | | | | ■ |
| RR510T | | • | • | | | ■ | | | ■ | | | ■ | | | ■ | | | | ■ | ■ |
| RR510Q | • | | | | | | | | | | | | | | | | | | | |
| RA510 | | • | • | | | | • | | | • | | | • | | | | • | | | |
| RA510D | | • | • | • | | | • | | | • | | | • | | | | • | | | |
| RA510T | | • | • | • | | | • | | | • | | | • | | | | • | | | |
| RR710 | | • | • | | | ■ | | ■ | ■ | | | ■ | | | ■ | | | | ■ | ■ |
| RR710D | | • | • | | | | | | | | | | | | | | | | | ■ |
| RR710T | | • | • | | | ■ | | | ■ | | | ■ | | | ■ | | | | ■ | ■ |
| RR710Q | • | | | | | | | | | | | | | | | | | | | |
| RA710 | | • | • | • | | | • | | | • | | | • | | | | • | | | |
| RA710D | | • | • | • | | | • | | | • | | | • | | | | • | | | |
| RA710T | | • | • | • | | | • | | | • | | | • | | | | • | | | |
| RR810 | | •1) | •1) | •1) | | | •1) | | | •1) | | | •1) | | | | •1) | | | |
| RR810D | | • | • | | | | ■ | | ■ | | | ■ | | | ■ | | | | | ■ |
| RR810T | | • | • | | | ■ | | | ■ | | | ■ | | | ■ | | | | ■ | ■ |
| RR810Q | • | | | | | | | | | | | | | | | | | | | |
| RA810 | | • | • | • | | | • | | | • | | | • | | | | • | | | |
| RA810D | | • | • | • | | | • | | | • | | | • | | | | • | | | |
| RA810T | | • | • | • | | | • | | | • | | | • | | | | • | | | |
| RR1010 | | •1) | •1) | •1) | | | •1) | | | •1) | | | •1) | | | | •1) | | | |
| RR1010D | | • | • | | | ■ | | ■ | ■ | | | ■ | | | ■ | | | | | ■ |
| RR1010T | | • | • | | | ■ | | ■ | ■ | | | ■ | | | ■ | | | | | ■ |
| RR1010Q | | • | • | | | ■ | | | ■ | | | ■ | | | ■ | | | | ■ | ■ |
| RA1010 (A) | | • | • | • | | | • | | | • | | | • | | | | • | | | |
| RA1010 (B) | | •1) | •1) | •1) | | | •1) | | | •1) | | | •1) | | | | •1) | | | |
| RA1010D | | • | • | • | | | • | | | • | | | • | | | | • | | | |
| RA1010T | | • | • | • | | | • | | | • | | | • | | | | • | | | |
| RR1700 | | •1) | •1) | •1) | | | •1) | | | •1) | | | •1) | | | | •1) | | | |
| RR1700D | | • | • | | | ■ | | ■ | ■ | | | ■ | | | ■ | | | | | ■ |
| RR1700T | | • | • | | | ■ | | ■ | ■ | | | ■ | | | ■ | | | | | ■ |
| RR1700Q | | • | • | | | ■ | | | ■ | | | ■ | | | ■ | | | | ■ | ■ |
| RA1700 (A) | | • | • | • | | | • | | | • | | | • | | | | • | | | |
| RA1700 (B) | | •1) | •1) | •1) | | | •1) | | | •1) | | | •1) | | | | •1) | | | |
| RA1700D | | • | • | • | | | • | | | • | | | • | | | | • | | | |
| RA1700T | | • | • | • | | | • | | | • | | | • | | | | • | | | |
| RF2/... CFG2 "A" | • | | | | | | | | | | | | | | | | | | | |
| RF2/... CFG2 "B" | | • | • | • | | | • | | | • | | | • | | | | • | | | |
| RF5/...-RFF5/... | | • | • | • | | | • | | | • | | | • | | | | • | | | |
| RF170±290 | | •1) | •1) | •1) | | | •1) | | | •1) | | | •1) | | | | •1) | | | |

- Ingresso standard / Standard input / Standardeingang / Entrée standard / Entrada standard / Entrada padrão (—)
 - Predisposizione RF / RF Setup / Auslegung RF / Préréglage RF / Predisposición RF / Predisposição RF
 - Predisposizione BOC / BOC Setup / Auslegung BOC / Préréglage BOC / Predisposición BOC / Predisposição BOC
- 1) Con / With / Mit / Avec / Con / Com **KIT CB01**

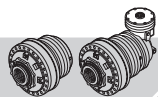

| | | SAUER DANFOSS | | | | | | | | | | | | | | | | | | |
|------------------|-----|------------------|----------|------------|-------------------|----------|----------|-------------|----------|-------------------|----------|------------|-------------|----------|-------------------|----------|----------|----------|----------|----------|
| | | OMS 12/24 z14 | | OMS ø32 | OMSS 12/24 z12 | | | OMT ø 40 | | OMTS 12/24 z16 | | | OMV ø 50 | | OMVS 10/20 z16 | | | | | |
| | | Code | 154F3441 | 154F3442 | 154-2256 | 154B2688 | 154B2691 | 154B2692 | 154F3443 | 154F3446 | 154B2690 | 154-2258M1 | 154-2267 | 154B2693 | 154B9758 | 154F3444 | 154F3445 | 154B2689 | 154-2263 | 154B2694 |
| X | 38 | 38 | 37 | 37 | 24 | 16.7 | 105 | 102 | 48 | 48 | 51 | 27.7 | 51 | 113 | 110 | 55 | 58 | 34.7 | 58 | |
| RR65 | | | | | | | | | | | | | | | | | | | | |
| RR65D | | | | | | | | | | | | | | | | | | | | |
| RR65T | | | | | | | | | | | | | | | | | | | | |
| RR105 | • | • | | | ■ | | | | | | ○ | | | | | | | | | |
| RR105D | | | | | | | | | | | | | | | | | | | | |
| RR105T | | | | | | | | | | | | | | | | | | | | |
| RA105 | • | • | • | | | | | | | | | | | | | | | | | |
| RA105D | • | • | • | | | | | | | | | | | | | | | | | |
| RR110 | • | • | | | ■ | | | | | | ○ | | | | | | | | | |
| RR110D | | | | | | | | | | | | | | | | | | | | |
| RR110T | | | | | | | | | | | | | | | | | | | | |
| RA110 | • | • | • | | | | | | | | | | | | | | | | | |
| RA110D | • | • | • | | | | | | | | | | | | | | | | | |
| RR210 | • | • | | | ■ | | | | | | ○ | | | | | | | | | |
| RR210D | • | • | | | | | | | | | | | | | | | | | | |
| RR210T | | | | | | | | | | | | | | | | | | | | |
| RR210Q | | | | | | | | | | | | | | | | | | | | |
| RA210 | • | • | • | | | | | | | | | | | | | | | | | |
| RA210D | • | • | • | | | | | | | | | | | | | | | | | |
| RR310 | • | • | | ■ | | | | ○ | | ■ | | | | | ○ | | ■ | | | |
| RR310D | • | • | | | ■ | | | | | | ○ | | | | | | | | | |
| RR310T | | | | | | | | | | | | | | | | | | | | |
| RR310Q | | | | | | | | | | | | | | | | | | | | |
| RA310 | • | • | • | | | | | | | | | | | | | | | | | |
| RA310D | • | • | • | | | | | | | | | | | | | | | | | |
| RA310T | • | • | • | | | | | | | | | | | | | | | | | |
| RR510 | • | • | | ■ | | | | ○ | | ■ | | | | | ○ | | ■ | | | |
| RR510D | • | • | | ■ | | | | | | ■ | | | | | ○ | | ■ | | | |
| RR510T | • | • | | | ■ | | | | | | ○ | | | | | | | | | |
| RR510Q | | | | | | | | | | | | | | | | | | | | |
| RA510 | • | • | | | | | | | | | | | | | | | | | | ■ |
| RA510D | • | • | • | | | | | | | | | | | | | | | | | |
| RA510T | • | • | • | | | | | | | | | | | | | | | | | |
| RR710 | • | • | | ■ | | | | ○ | | ■ | | | | | ○ | | ■ | | | |
| RR710D | • | • | | ■ | | | | | | ■ | | | | | ○ | | ■ | | | |
| RR710T | • | • | | | ■ | | | | | | ○ | | | | | | | | | |
| RR710Q | | | | | | | | | | | | | | | | | | | | |
| RA710 | • | • | | | | | | | | ■ | | | | | | | | | | ■ |
| RA710D | • | • | • | | | | | | | | | | | | | | | | | |
| RA710T | • | • | • | | | | | | | | | | | | | | | | | |
| RR810 | •1) | •1) | •1) | | | | | | • | | | | | | | • | | • | | |
| RR810D | • | • | | ■ | | | | ○ | | ■ | | | | | ○ | | ■ | | | |
| RR810T | • | • | | | ■ | | | | | | ○ | | | | | | | | | |
| RR810Q | | | | | | | | | | | | | | | | | | | | |
| RA810 | • | • | | | | | | | | ■ | | | | | | | | | | ■ |
| RA810D | • | • | • | | | | | | | | | | | | | | | | | |
| RA810T | • | • | • | | | | | | | | | | | | | | | | | |
| RR1010 | •1) | •1) | •1) | | | | | | • | | | | | | • | | • | | | |
| RR1010D | • | • | | ■ | | | | ○ | | ■ | | | | | ○ | | ■ | | | |
| RR1010T | • | • | | ■ | | | | | | ■ | | | | | ○ | | ■ | | | |
| RR1010Q | | | | | ■ | | | | | | ○ | | | | | | | | | |
| RA1010 (A) | • | • | | | | | | | | ■ | | | | | | | | | | ■ |
| RA1010 (B) | •1) | •1) | •1) | | | | | | • | | | | | | • | | • | | | ■ |
| RA1010D | • | • | | | | | | | | ■ | | | | | ■ | | | | | ■ |
| RA1010T | • | • | • | | | | | | | | | | | | | | | | | |
| RR1700 | •1) | •1) | •1) | | | | | | • | | | | | | • | | • | | | |
| RR1700D | • | • | | ■ | | | | ○ | | ■ | | | | | ○ | | ■ | | | |
| RR1700T | • | • | | ■ | | | | | | ○ | | | | | ○ | | ■ | | | |
| RR1700Q | • | • | | | ■ | | | | | | ○ | | | | | | | | | |
| RA1700 (A) | • | • | | | | | | | | ■ | | | | | | | | | | ■ |
| RA1700 (B) | •1) | •1) | •1) | | | | | | • | | | | | | • | | • | | | ■ |
| RA1700D | • | • | | | | | | | | ■ | | | | | ■ | | | | | ■ |
| RA1700T | • | • | • | | | | | | | | | | | | | | | | | |
| RF2/... CFG2 "A" | | | | | | | | | | | | | | | | | | | | |
| RF2/... CFG2 "B" | | | | | | | | | | | | | | | | | | | | |
| RF5/...-RFF5/... | • | • | • | | | | | | | | | | | | | | | | | |
| RF170=290 | •1) | •1) | •1) | | | | | | • | | | | | | • | | • | | | • |

- Ingresso standard / Standard input / Standardeingang / Entrée standard / Entrada standard / Entrada padrão (—)
 - Predisposizione RF / RF Setup / Auslegung RF / Préréglage RF / Predisposición RF / Predisposição RF
 - Predisposizione BOC / BOC Setup / Auslegung BOC / Préréglage BOC / Predisposición BOC / Predisposição BOC
- 1) Con / With / Mit / Avec / Con / Com **KIT CB01**

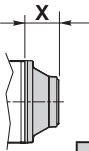
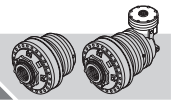

BOSCH REXROTH

| Code | A2FM10-12-16 ø20 | A2FM10-12-16 25x1,25x18 | A2FM23-28-32 ø25 | A2FM23-28-32 ø30 | A2FM23-28-32 25x1,25x18 | A2FM23-28-32 30x2x14 | A2FM45 ø30 | A2FM45 30x2x14 | A2FM45 32x2x14 | A2FM56 30x2x14 | A2FM56 35x2x16 | A2FM63 35x2x16 | A2FM80 ø35 | A2FM80 35x2x16 | A2FM80 40x2x18 | A2FM90 ø40 | A2FM90 40x2x18 | A2FM107 ø40 | | | |
|------------------|------------------|-------------------------|------------------|------------------|-------------------------|----------------------|--------------|----------------|----------------|----------------|----------------|----------------|-------------|----------------|----------------|--------------|----------------|--------------|--------------|-------------|--------------|
| | 154-2300M68 | 154-2300M371 | 154-2300M73 | 154-2300M66 | 154-2300M216 | 154-2300M77 | 154-2300M417 | 154-2300M63 | 154-2300M76 | 154-2300M312 | 154-2300M76 | 154-2300M75 | 154-2300M75 | 154-2300M445 | 154-2300M67 | 154-2300M194 | 154-2300M48 | 154-2300M191 | 154-2300M422 | 154-2300M48 | 154-2300M369 |
| X | 55 | 44 | 39 | 71 | 62 | 46 | 46 | 62 | 62 | 62 | 62 | 62 | 74 | 57 | 65 | 57 | 65 | 106 | 57 | 113 | |
| RR65 | | • | | | | | | | | | | | | | | | | | | | |
| RR65D | | • | | | | | | | | | | | | | | | | | | | |
| RR65T | | • | | | | | | | | | | | | | | | | | | | |
| RR105 | • | | • | • | • | • | • | • | • | • | • | • | • | • | • | | | | | • | |
| RR105D | | • | | | | | | | | | | | | | | | | | | | |
| RR105T | | • | | | | | | | | | | | | | | | | | | | |
| RA105 | • | | • | • | • | • | • | • | • | • | • | • | • | • | • | | | | | • | |
| RA105D | • | | • | • | • | • | • | • | • | • | • | • | • | • | • | | | | | • | |
| RR110 | • | | • | • | • | • | • | • | • | • | • | • | • | • | • | | | | | • | |
| RR110D | | • | | | | | | | | | | | | | | | | | | | |
| RR110T | | • | | | | | | | | | | | | | | | | | | | |
| RA110 | • | | • | • | • | • | • | • | • | • | • | • | • | • | • | | | | | • | |
| RA110D | • | | • | • | • | • | • | • | • | • | • | • | • | • | • | | | | | • | |
| RR210 | • | | • | • | • | • | • | • | • | • | • | • | • | • | • | | | | | • | |
| RR210D | | • | | | | | | | | | | | | | | | | | | | |
| RR210T | | • | | | | | | | | | | | | | | | | | | | |
| RR210Q | | • | | | | | | | | | | | | | | | | | | | |
| RA210 | • | | • | • | • | • | • | • | • | • | • | • | • | • | • | | | | | • | |
| RA210D | • | | • | • | • | • | • | • | • | • | • | • | • | • | • | | | | | • | |
| RR310 | • | | • | • | • | • | • | • | • | • | • | • | • | • | • | | | | ○ | | ○ |
| RR310D | • | | • | • | • | • | • | • | • | • | • | • | • | • | • | | | | | • | |
| RR310T | | • | | | | | | | | | | | | | | | | | | | |
| RR310Q | | • | | | | | | | | | | | | | | | | | | | |
| RA310 | • | | • | • | • | • | • | • | • | • | • | • | • | • | • | | | | | • | |
| RA310D | • | | • | • | • | • | • | • | • | • | • | • | • | • | • | | | | | • | |
| RA310T | • | | • | • | • | • | • | • | • | • | • | • | • | • | • | | | | | • | |
| RR510 | • | | • | • | • | • | • | • | • | • | • | • | • | • | • | | | | ○ | | ○ |
| RR510D | • | | • | • | • | • | • | • | • | • | • | • | • | • | • | | | | ○ | | ○ |
| RR510T | • | | • | • | • | • | • | • | • | • | • | • | • | • | • | | | | | • | |
| RR510Q | • | | • | | | | | | | | | | | | | | | | | | |
| RA510 | • | | • | • | • | • | • | • | • | • | • | • | • | • | • | | | | | • | |
| RA510D | • | | • | • | • | • | • | • | • | • | • | • | • | • | • | | | | | • | |
| RA510T | • | | • | • | • | • | • | • | • | • | • | • | • | • | • | | | | | • | |
| RR710 | • | | • | • | • | • | • | • | • | • | • | • | • | • | • | | | | ○ | | ○ |
| RR710D | • | | • | • | • | • | • | • | • | • | • | • | • | • | • | | | | ○ | | ○ |
| RR710T | • | | • | • | • | • | • | • | • | • | • | • | • | • | • | | | | | • | |
| RR710Q | • | | • | | | | | | | | | | | | | | | | | | |
| RA710 | • | | • | • | • | • | • | • | • | • | • | • | • | • | • | | | | | • | |
| RA710D | • | | • | • | • | • | • | • | • | • | • | • | • | • | • | | | | | • | |
| RA710T | • | | • | • | • | • | • | • | • | • | • | • | • | • | • | | | | | • | |
| RR810 | • 1) | | • 1) | • 1) | • 1) | • 1) | • 1) | • 1) | • 1) | • 1) | • 1) | • 1) | • 1) | • 1) | • | | | | | • 1) | |
| RR810D | • | | • | • | • | • | • | • | • | • | • | • | • | • | • | | | | | • | |
| RR810T | • | | • | • | • | • | • | • | • | • | • | • | • | • | • | | | | | • | |
| RR810Q | • | | • | | | | | | | | | | | | | | | | | | |
| RA810 | • | | • | • | • | • | • | • | • | • | • | • | • | • | • | | | | | • | |
| RA810D | • | | • | • | • | • | • | • | • | • | • | • | • | • | • | | | | | • | |
| RA810T | • | | • | • | • | • | • | • | • | • | • | • | • | • | • | | | | | • | |
| RR1010 | • 1) | | • 1) | • 1) | • 1) | • 1) | • 1) | • 1) | • 1) | • 1) | • 1) | • 1) | • 1) | • 1) | • | | | | | • 1) | |
| RR1010D | • | | • | • | • | • | • | • | • | • | • | • | • | • | • | | | | | • | |
| RR1010T | • | | • | • | • | • | • | • | • | • | • | • | • | • | • | | | | | • | |
| RR1010Q | • | | • | | | | | | | | | | | | | | | | | | |
| RA1010 (A) | • | | • | • | • | • | • | • | • | • | • | • | • | • | • | | | | | • | |
| RA1010 (B) | • 1) | | • 1) | • 1) | • 1) | • 1) | • 1) | • 1) | • 1) | • 1) | • 1) | • 1) | • 1) | • 1) | • | | | | | • 1) | |
| RA1010D | • | | • | • | • | • | • | • | • | • | • | • | • | • | • | | | | | • | |
| RA1010T | • | | • | • | • | • | • | • | • | • | • | • | • | • | • | | | | | • | |
| RR1700 | • 1) | | • 1) | • 1) | • 1) | • 1) | • 1) | • 1) | • 1) | • 1) | • 1) | • 1) | • 1) | • 1) | • | | | | | • 1) | |
| RR1700D | • | | • | • | • | • | • | • | • | • | • | • | • | • | • | | | | | • | |
| RR1700T | • | | • | • | • | • | • | • | • | • | • | • | • | • | • | | | | | • | |
| RR1700Q | • | | • | | | | | | | | | | | | | | | | | | |
| RA1700 (A) | • | | • | • | • | • | • | • | • | • | • | • | • | • | • | | | | | • | |
| RA1700 (B) | • 1) | | • 1) | • 1) | • 1) | • 1) | • 1) | • 1) | • 1) | • 1) | • 1) | • 1) | • 1) | • 1) | • | | | | | • 1) | |
| RA1700D | • | | • | • | • | • | • | • | • | • | • | • | • | • | • | | | | | • | |
| RA1700T | • | | • | • | • | • | • | • | • | • | • | • | • | • | • | | | | | • | |
| RF2/... CFG2 "A" | • | | • | | | | | | | | | | | | | | | | | | |
| RF2/... CFG2 "B" | • | | • | | | | | | | | | | | | | | | | | | |
| RF5/...-RFF5/... | • | | • | | | | | | | | | | | | | | | | | | |
| RF170-290 | • 1) | | • 1) | • 1) | • 1) | • 1) | • 1) | • 1) | • 1) | • 1) | • 1) | • 1) | • 1) | • | | | | | | • 1) | |

- Ingresso standard / Standard input / Standardeingang / Entrée standard / Entrada standard / Entrada padrão (—)
- Predisposizione RF / RF Setup / Auslegung RF / Préréglage RF / Predisposición RF / Predisposição RF
- Predisposizione BOC / BOC Setup / Auslegung BOC / Préréglage BOC / Predisposición BOC / Predisposição BOC
- 1) Con / With / Mit / Avec / Con / Com **KIT CB01**

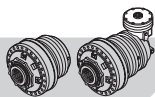

| | | BOSCH REXROTH | | | | | | | | | | | | | | | | | | | | | | | | | | | | | | | | | |
|------------------|------|--------------------|--------------|--------------|-------------|--------------------|--------------|--------------------|--------------|--------------------|--------------|--------------------|-------------|--------------------|-------------|--------------------|--------------|----------------------|--------------|-------------------|--------------|-------------------|--------------|-------------------|--|--------------------|--|--------------------|--|--------------------|--|--------------------|--|--------------------|--|
| | | A2FM107 40x2x18 | | | | A2FM107 45x2x21 | | A2FM160 45x2x21 | | A2FM160 50x2x24 | | A2FM180 50x2x24 | | A2FM200 50x2x24 | | A2FM250 50x2x24 | | A6VM28 25x1,25x18 | | A6VM55 30x2x14 | | A6VM55 35x2x16 | | A6VM80 35x2x16 | | A6VM107 40x2x18 | | A6VM160 45x2x21 | | A6VM160 50x2x24 | | A6VM200 50x2x24 | | A6VM250 50x2x24 | |
| | | Code | 154-2300M426 | 154-2300M397 | 154-2300M49 | 154-2300M649 | 154-2300M648 | 154-2300M649 | 154-2300M648 | 154-2300M759 | 154-2300M709 | 154-2300M192 | 154-2300M77 | 154-2300M76 | 154-2300M75 | 154-2300M67 | 154-2300M362 | 154-2300M49 | 154-2300M414 | 154-2300M649 | 154-2300M648 | 154-2300M448 | 154-2300M759 | 154-2300M716 | | | | | | | | | | | |
| X | 65 | 113 | 110 | 110 | 78 | 110 | 78 | 120 | 129 | 115 | 46 | 62 | 62 | 57 | 74 | 110 | 78 | 110 | 78 | 117 | 120 | 115 | | | | | | | | | | | | | |
| RR65 | | | | | | | | | | | | | | | | | | | | | | | | | | | | | | | | | | | |
| RR65D | | | | | | | | | | | | | | | | | | | | | | | | | | | | | | | | | | | |
| RR65T | | | | | | | | | | | | | | | | | | | | | | | | | | | | | | | | | | | |
| RR105 | ● | ● | ● | | | | | ● | ● | | ● | ● | ● | ● | | | ● | | | | | ● | | | | | | | | | | | | | |
| RR105D | | | | | | | | | | | | | | | | | | | | | | | | | | | | | | | | | | | |
| RR105T | | | | | | | | | | | | | | | | | | | | | | | | | | | | | | | | | | | |
| RA105 | ● | ● | ● | | | | | ● | ● | | ● | ● | ● | ● | | | ● | | | | | ● | | | | | | | | | | | | | |
| RA105D | ● | ● | ● | | | | | ● | ● | | ● | ● | ● | ● | | | ● | | | | | ● | | | | | | | | | | | | | |
| RR110 | ● | ● | ● | | | | | ● | ● | | ● | ● | ● | ● | | | ● | | | | | ● | | | | | | | | | | | | | |
| RR110D | | | | | | | | | | | | | | | | | | | | | | | | | | | | | | | | | | | |
| RR110T | | | | | | | | | | | | | | | | | | | | | | | | | | | | | | | | | | | |
| RA110 | ● | ● | ● | | | | | ● | ● | | ● | ● | ● | ● | | | ● | | | | | ● | | | | | | | | | | | | | |
| RA110D | ● | ● | ● | | | | | ● | ● | | ● | ● | ● | ● | | | ● | | | | | ● | | | | | | | | | | | | | |
| RR210 | ● | ● | ● | | | | | ● | ● | | ● | ● | ● | ● | | | ● | | | | | ● | | | | | | | | | | | | | |
| RR210D | ● | ● | ● | | | | | ● | ● | | ● | ● | ● | ● | | | ● | | | | | ● | | | | | | | | | | | | | |
| RR210T | | | | | | | | | | | | | | | | | | | | | | | | | | | | | | | | | | | |
| RR210Q | | | | | | | | | | | | | | | | | | | | | | | | | | | | | | | | | | | |
| RA210 | ● | ● | ● | | | | | ● | ● | | ● | ● | ● | ● | | | ● | | | | | ● | | | | | | | | | | | | | |
| RA210D | ● | ● | ● | | | | | ● | ● | | ● | ● | ● | ● | | | ● | | | | | ● | | | | | | | | | | | | | |
| RR310 | ● | ● | ● | ○ | | ○ | | ● | ● | | ● | ● | ● | ● | | ○ | ● | | | ○ | | ● | | | | | | | | | | | | | |
| RR310D | ● | ● | ● | | | | | ● | ● | | ● | ● | ● | ● | | | ● | | | | | ● | | | | | | | | | | | | | |
| RR310T | | | | | | | | | | | | | | | | | | | | | | | | | | | | | | | | | | | |
| RR310Q | | | | | | | | | | | | | | | | | | | | | | | | | | | | | | | | | | | |
| RA310 | ● | ● | ● | | | | | ● | ● | | ● | ● | ● | ● | | | ● | | | | | ● | | | | | | | | | | | | | |
| RA310D | ● | ● | ● | | | | | ● | ● | | ● | ● | ● | ● | | | ● | | | | | ● | | | | | | | | | | | | | |
| RA310T | ● | ● | ● | | | | | ● | ● | | ● | ● | ● | ● | | | ● | | | | | ● | | | | | | | | | | | | | |
| RR510 | ● | ● | ● | ○ | | ○ | | ● | ● | | ● | ● | ● | ● | | ○ | ● | | | ○ | | ● | | | | | | | | | | | | | |
| RR510D | ● | ● | ● | | | | | ● | ● | | ● | ● | ● | ● | | | ● | | | | | ● | | | | | | | | | | | | | |
| RR510T | ● | ● | ● | | | | | ● | ● | | ● | ● | ● | ● | | | ● | | | | | ● | | | | | | | | | | | | | |
| RR510Q | | | | | | | | | | | | | | | | | | | | | | | | | | | | | | | | | | | |
| RA510 | ● | ● | ● | | | | | ● | ● | | ● | ● | ● | ● | | | ● | | | | | ● | | | | | | | | | | | | | |
| RA510D | ● | ● | ● | | | | | ● | ● | | ● | ● | ● | ● | | | ● | | | | | ● | | | | | | | | | | | | | |
| RA510T | ● | ● | ● | | | | | ● | ● | | ● | ● | ● | ● | | | ● | | | | | ● | | | | | | | | | | | | | |
| RR710 | ● | ● | ● | ○ | | ○ | | ● | ● | | ● | ● | ● | ● | | ○ | ● | | | ○ | | ● | | | | | | | | | | | | | |
| RR710D | ● | ● | ● | | | | | ● | ● | | ● | ● | ● | ● | | | ● | | | | | ● | | | | | | | | | | | | | |
| RR710T | ● | ● | ● | | | | | ● | ● | | ● | ● | ● | ● | | | ● | | | | | ● | | | | | | | | | | | | | |
| RR710Q | | | | | | | | | | | | | | | | | | | | | | | | | | | | | | | | | | | |
| RA710 | ● | ● | ● | | | | | ● | ● | | ● | ● | ● | ● | | | ● | | | | | ● | | | | | | | | | | | | | |
| RA710D | ● | ● | ● | | | | | ● | ● | | ● | ● | ● | ● | | | ● | | | | | ● | | | | | | | | | | | | | |
| RA710T | ● | ● | ● | | | | | ● | ● | | ● | ● | ● | ● | | | ● | | | | | ● | | | | | | | | | | | | | |
| RR810 | ● 1) | ● 1) | ● 1) | ● | | ○ | | ● 1) | ● | | ● 1) | ● 1) | ● 1) | ● 1) | | | ● 1) | | | ○ | | ● 1) | | | | | | | | | | | | | |
| RR810D | ● | ● | ● | ○ | | ○ | | ● | ● | | ● | ● | ● | ● | | ○ | ● | | | ○ | | ● | | | | | | | | | | | | | |
| RR810T | ● | ● | ● | | | | | ● | ● | | ● | ● | ● | ● | | | ● | | | | | ● | | | | | | | | | | | | | |
| RR810Q | | | | | | | | | | | | | | | | | | | | | | | | | | | | | | | | | | | |
| RA810 | ● | ● | ● | | | | | ● | ● | | ● | ● | ● | ● | | | ● | | | | | ● | | | | | | | | | | | | | |
| RA810D | ● | ● | ● | | | | | ● | ● | | ● | ● | ● | ● | | | ● | | | | | ● | | | | | | | | | | | | | |
| RA810T | ● | ● | ● | | | | | ● | ● | | ● | ● | ● | ● | | | ● | | | | | ● | | | | | | | | | | | | | |
| RR1010 | ● 1) | ● 1) | ● 1) | ● | | ○ | | ● 1) | ● | | ● 1) | ● 1) | ● 1) | ● 1) | | | ● 1) | | | ○ | | ● 1) | | | | | | | | | | | | | |
| RR1010D | ● | ● | ● | | | ○ | | ● | ● | | ● | ● | ● | ● | | ○ | ● | | | ○ | | ● | | | | | | | | | | | | | |
| RR1010T | ● | ● | ● | ○ | | ○ | | ● | ● | | ● | ● | ● | ● | | | ● | | | | | ● | | | | | | | | | | | | | |
| RR1010Q | | | | | | | | | | | | | | | | | | | | | | | | | | | | | | | | | | | |
| RA1010 (A) | ● | ● | ● | | | | | ● | ● | | ● | ● | ● | ● | | | ● | | | | | ● | | | | | | | | | | | | | |
| RA1010 (B) | ● 1) | ● 1) | ● 1) | ● | | ○ | | ● 1) | ● | | ● 1) | ● 1) | ● 1) | ● 1) | | | ● 1) | | | | | ● 1) | | | | | | | | | | | | | |
| RA1010D | ● | ● | ● | | | | | ● | ● | | ● | ● | ● | ● | | | ● | | | | | ● | | | | | | | | | | | | | |
| RA1010T | ● | ● | ● | | | | | ● | ● | | ● | ● | ● | ● | | | ● | | | | | ● | | | | | | | | | | | | | |
| RR1700 | ● 1) | ● 1) | ● 1) | ● | | ○ | | ● 1) | ● | | ● 1) | ● 1) | ● 1) | ● 1) | | | ● 1) | | | ○ | | ● 1) | | | | | | | | | | | | | |
| RR1700D | ● | ● | ● | ○ | | ○ | | ● | ● | | ● | ● | ● | ● | | | ● | | | ○ | | ● | | | | | | | | | | | | | |
| RR1700T | ● | ● | ● | ○ | | ○ | | ● | ● | | ● | ● | ● | ● | | | ● | | | ○ | | ● | | | | | | | | | | | | | |
| RR1700Q | | | | | | | | | | | | | | | | | | | | | | | | | | | | | | | | | | | |
| RA1700 (A) | ● | ● | ● | | | | | ● | ● | | ● | ● | ● | ● | | | ● | | | | | ● | | | | | | | | | | | | | |
| RA1700 (B) | ● 1) | ● 1) | ● 1) | ● | | ○ | | ● 1) | ● | | ● 1) | ● 1) | ● 1) | ● 1) | | | ● 1) | | | ○ | | ● 1) | | | | | | | | | | | | | |
| RA1700D | ● | ● | ● | | | | | ● | ● | | ● | ● | ● | ● | | | ● | | | | | ● | | | | | | | | | | | | | |
| RA1700T | ● | ● | ● | | | | | ● | ● | | ● | ● | ● | ● | | | ● | | | | | ● | | | | | | | | | | | | | |
| RF2/... CFG2 "A" | | | | | | | | | | | | | | | | | | | | | | | | | | | | | | | | | | | |
| RF2/... CFG2 "B" | | | | | | | | | | | | | | | | | | | | | | | | | | | | | | | | | | | |
| RF5/...-RFF5/... | ● | ● | ● | | | | | ● | ● | | ● | ● | ● | ● | | | ● | | | | | ● | | | | | | | | | | | | | |
| RF170±290 | ● 1) | ● 1) | ● 1) | ● | | ○ | | ● 1) | ● | | ● 1) | ● 1) | ● 1) | ● 1) | | | ● 1) | | | | | ● 1) | | | | | | | | | | | | | |

● Ingresso standard / Standard input / Standardeingang / Entrée standard / Entrada standard / Entrada padrão (—)
 ■ Predisposizione RF / RF Setup / Auslegung RF / Préréglage RF / Predisposición RF / Predisposição RF
 ○ Predisposizione BOC / BOC Setup / Auslegung BOC / Préréglage BOC / Predisposición BOC / Predisposição BOC
 1) Con / With / Mit / Avec / Con / Com KIT CB01

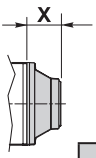

|  | CALZONI | | | | | | | | | | | CHAR-LYNN (EATON) | | | | |
|---|----------|--------------|--------------|--------------|--------------|--------------|--------------|--------------|--------------|--------------|-------------------------------------|-------------------------------------|-----------------------------------|---|---------------------------------------|--------------|
| | MR 190 N | MR 300 N | | | MR 450 N | MR 700 N | MR 1100 N | MRV 450 | | MRV 700 | SERIE 2000 SAE A 2B 12/24 Z14 | SERIE 2000 SAE A 4B 12/24 Z14 | SERIE 2000 SAE A 2B ø1 1/4" | SERIE 2000 BEARIN- GLESS 12/24 z12 | SERIE 6000 SAE C 2/4B 12/24 z17 | |
| | Code | 154-2300M109 | 154-2300M156 | 154-2300M206 | 154-2300M157 | 154-2300M204 | 154-2300M205 | 154-2300M207 | 154-2300M373 | 154-2300M415 | 154-2300M374 | 154-2300M734 | 154-2300M553 | 154-2300M220 | 154-2300M457 | 154-2300M111 |
| X | 50 | 70 | 67.5 | 91 | 85.5 | 90 | 104 | 30 | 98 | 33 | 40 | 38 | 41 | 37 | 47.5 | |
| RR65 | | | | | | | | | | | | | | | | |
| RR65D | | | | | | | | | | | | | | | | |
| RR65T | | | | | | | | | | | | | | | | |
| RR105 | • | | | | | | | | | | • | • | • | • | • | • |
| RR105D | | | | | | | | | | | | | | | | |
| RR105T | | | | | | | | | | | | | | | | |
| RA105 | • | | | | | | | | | | • | • | • | • | • | • |
| RA105D | • | | | | | | | | | | • | • | • | • | • | • |
| RR110 | • | | | | | | | | | | • | • | • | • | • | • |
| RR110D | | | | | | | | | | | | | | | | |
| RR110T | | | | | | | | | | | | | | | | |
| RA110 | • | | | | | | | | | | • | • | • | • | • | • |
| RA110D | • | | | | | | | | | | • | • | • | • | • | • |
| RR210 | • | | | | | | | | | | • | • | • | • | • | • |
| RR210D | • | | | | | | | | | | • | • | • | • | • | • |
| RR210T | | | | | | | | | | | | | | | | |
| RR210Q | | | | | | | | | | | | | | | | |
| RA210 | • | | | | | | | | | | • | • | • | • | • | • |
| RA210D | • | | | | | | | | | | • | • | • | • | • | • |
| RR310 | • | ○ | | ○ | | | | | ○ | | • | • | • | • | • | • |
| RR310D | • | | | | | | | | | | • | • | • | • | • | • |
| RR310T | | | | | | | | | | | | | | | | |
| RR310Q | | | | | | | | | | | | | | | | |
| RA310 | • | | | | | | | | | | • | • | • | • | • | • |
| RA310D | • | | | | | | | | | | • | • | • | • | • | • |
| RA310T | • | | | | | | | | | | • | • | • | • | • | • |
| RR510 | • | ○ | | ○ | | | | | ○ | | • | • | • | • | • | • |
| RR510D | • | ○ | | ○ | | | | | ○ | | • | • | • | • | • | • |
| RR510T | • | | | | | | | | | | • | • | • | • | • | • |
| RR510Q | | | | | | | | | | | | | | | | |
| RA510 | • | | | | | | | | | | • | • | • | • | • | • |
| RA510D | • | | | | | | | | | | • | • | • | • | • | • |
| RA510T | • | | | | | | | | | | • | • | • | • | • | • |
| RR710 | • | ○ | | ○ | | | | | ○ | | • | • | • | • | • | • |
| RR710D | • | ○ | | ○ | | | | | ○ | | • | • | • | • | • | • |
| RR710T | • | | | | | | | | | | • | • | • | • | • | • |
| RR710Q | | | | | | | | | | | | | | | | |
| RA710 | • | | | | | | | | | | • | • | • | • | • | • |
| RA710D | • | | | | | | | | | | • | • | • | • | • | • |
| RA710T | • | | | | | | | | | | • | • | • | • | • | • |
| RR810 | • 1) | • | • | • | • | • | • | • | • | • | • 1) | • 1) | • 1) | • 1) | • 1) | • 1) |
| RR810D | • | ○ | | ○ | | | | | ○ | | • | • | • | • | • | • |
| RR810T | • | | | | | | | | | | • | • | • | • | • | • |
| RR810Q | | | | | | | | | | | | | | | | |
| RA810 | • | | | | | | | | | | • | • | • | • | • | • |
| RA810D | • | | | | | | | | | | • | • | • | • | • | • |
| RA810T | • | | | | | | | | | | • | • | • | • | • | • |
| RR1010 | • 1) | • | • | • | • | • | • | • | • | • | • 1) | • 1) | • 1) | • 1) | • 1) | • 1) |
| RR1010D | • | ○ | | ○ | | | | | ○ | | • | • | • | • | • | • |
| RR1010T | • | ○ | | ○ | | | | | ○ | | • | • | • | • | • | • |
| RR1010Q | • | | | | | | | | | | | | | | | |
| RA1010 (A) | • | | | | | | | | | | • | • | • | • | • | • |
| RA1010 (B) | • 1) | • | • | • | • | • | • | • | • | • | • 1) | • 1) | • 1) | • 1) | • 1) | • 1) |
| RA1010D | • | | | | | | | | | | • | • | • | • | • | • |
| RA1010T | • | | | | | | | | | | • | • | • | • | • | • |
| RR1700 | • 1) | • | • | • | • | • | • | • | • | • | • 1) | • 1) | • 1) | • 1) | • 1) | • 1) |
| RR1700D | • | ○ | | ○ | | | | | ○ | | • | • | • | • | • | • |
| RR1700T | • | ○ | | ○ | | | | | ○ | | • | • | • | • | • | • |
| RR1700Q | • | | | | | | | | | | | | | | | |
| RA1700 (A) | • | | | | | | | | | | • | • | • | • | • | • |
| RA1700 (B) | • 1) | • | • | • | • | • | • | • | • | • | • 1) | • 1) | • 1) | • 1) | • 1) | • 1) |
| RA1700D | • | | | | | | | | | | • | • | • | • | • | • |
| RA1700T | • | | | | | | | | | | • | • | • | • | • | • |
| RF2/... CFG2 "A" | | | | | | | | | | | | | | | | |
| RF2/... CFG2 "B" | • | | | | | | | | | | • | • | • | • | • | • |
| RF5/...-RFF5/... | • | | | | | | | | | | • | • | • | • | • | • |
| RF170±290 | • 1) | • | • | • | • | • | • | • | • | • | • 1) | • 1) | • 1) | • 1) | • 1) | • 1) |

- Ingresso standard / Standard input / Standardeingang / Entrée standard / Entrada standard / Entrada padrão (—)
 - Predisposizione RF / RF Setup / Auslegung RF / Préréglage RF / Predisposición RF / Predisposição RF
 - Predisposizione BOC / BOC Setup / Auslegung BOC / Préréglage BOC / Predisposición BOC / Predisposição BOC
- 1) Con / With / Mit / Avec / Con / Com **KIT CB01**

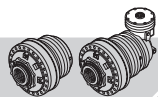

| | DINAMICOIL | | LINDE | | | | | | OLIOSTIP | | | |
|------------------|-----------------------|----------------|---------------------|---------------------|-----------|--------------------|-------------------|-------------------|------------|------------|------------|----|
| | AH100 BH50/175/200 | CH250 DH300 | MMF 43 16/32 z15 | MMF 63 12/24 z14 | HMF 28-35 | HMF 50-75 HMV75 | HMF 105 HMV105 | HMF 135 HMV135 | RMF100-150 | RMF200-300 | RMF400-600 | |
| | Code | Code | Code | Code | Code | Code | Code | Code | Code | Code | Code | |
| X | 50 | 50 | 24 | 31.5 | 24 | 31.5 | 31.5 | 124 | 50 | 50 | 64.5 | 75 |
| RR65 | | | | | | | | | | | | |
| RR65D | | | | | | | | | | | | |
| RR65T | | | | | | | | | | | | |
| RR105 | • | • | • | • | • | • | • | • | • | • | | |
| RR105D | | | | | | | | | | | | |
| RR105T | | | | | | | | | | | | |
| RA105 | • | • | • | • | • | • | • | • | • | • | | |
| RA105D | • | • | • | • | • | • | • | • | • | • | | |
| RR110 | • | • | • | • | • | • | • | • | • | • | | |
| RR110D | | | | | | | | | | | | |
| RR110T | | | | | | | | | | | | |
| RA110 | • | • | • | • | • | • | • | • | • | • | | |
| RA110D | • | • | • | • | • | • | • | • | • | • | | |
| RR210 | • | • | • | • | • | • | • | • | • | • | | |
| RR210D | • | • | • | • | • | • | • | • | • | • | | |
| RR210T | | | | | | | | | | | | |
| RR210Q | | | | | | | | | | | | |
| RA210 | • | • | • | • | • | • | • | • | • | • | | |
| RA210D | • | • | • | • | • | • | • | • | • | • | | |
| RR310 | • | • | • | • | • | • | • | • | • | • | | |
| RR310D | • | • | • | • | • | • | • | • | • | • | | |
| RR310T | | | | | | | | | | | | |
| RR310Q | | | | | | | | | | | | |
| RA310 | • | • | • | • | • | • | • | • | • | • | | |
| RA310D | • | • | • | • | • | • | • | • | • | • | | |
| RA310T | • | • | • | • | • | • | • | • | • | • | | |
| RR510 | • | • | • | • | • | • | • | • | • | • | | |
| RR510D | • | • | • | • | • | • | • | • | • | • | | |
| RR510T | • | • | • | • | • | • | • | • | • | • | | |
| RR510Q | | | | | | | | | | | | |
| RA510 | • | • | • | • | • | • | • | • | • | • | | |
| RA510D | • | • | • | • | • | • | • | • | • | • | | |
| RA510T | • | • | • | • | • | • | • | • | • | • | | |
| RR710 | • | • | • | • | • | • | • | • | • | • | | |
| RR710D | • | • | • | • | • | • | • | • | • | • | | |
| RR710T | • | • | • | • | • | • | • | • | • | • | | |
| RR710Q | | | | | | | | | | | | |
| RA710 | • | • | • | • | • | • | • | • | • | • | | |
| RA710D | • | • | • | • | • | • | • | • | • | • | | |
| RA710T | • | • | • | • | • | • | • | • | • | • | | |
| RR810 | • 1) | • 1) | • 1) | • 1) | • 1) | • 1) | • 1) | • 1) | • 1) | • | | • |
| RR810D | • | • | • | • | • | • | • | • | • | • | | |
| RR810T | • | • | • | • | • | • | • | • | • | • | | |
| RR810Q | | | | | | | | | | | | |
| RA810 | • | • | • | • | • | • | • | • | • | • | | |
| RA810D | • | • | • | • | • | • | • | • | • | • | | |
| RA810T | • | • | • | • | • | • | • | • | • | • | | |
| RR1010 | • 1) | • 1) | • 1) | • 1) | • 1) | • 1) | • 1) | • 1) | • 1) | • | | • |
| RR1010D | • | • | • | • | • | • | • | • | • | • | | |
| RR1010T | • | • | • | • | • | • | • | • | • | • | | |
| RR1010Q | | | | | | | | | | | | |
| RA1010 (A) | • | • | • | • | • | • | • | • | • | • | | |
| RA1010 (B) | • 1) | • 1) | • 1) | • 1) | • 1) | • 1) | • 1) | • 1) | • 1) | • | | • |
| RA1010D | • | • | • | • | • | • | • | • | • | • | | |
| RA1010T | • | • | • | • | • | • | • | • | • | • | | |
| RR1700 | • 1) | • 1) | • 1) | • 1) | • 1) | • 1) | • 1) | • 1) | • 1) | • | | • |
| RR1700D | • | • | • | • | • | • | • | • | • | • | | |
| RR1700T | • | • | • | • | • | • | • | • | • | • | | |
| RR1700Q | • | • | • | • | • | • | • | • | • | • | | |
| RA1700 (A) | • | • | • | • | • | • | • | • | • | • | | |
| RA1700 (B) | • 1) | • 1) | • 1) | • 1) | • 1) | • 1) | • 1) | • 1) | • 1) | • | | • |
| RA1700D | • | • | • | • | • | • | • | • | • | • | | |
| RA1700T | • | • | • | • | • | • | • | • | • | • | | |
| RF2/... CFG2 "A" | | | | | | | | | | | | |
| RF2/... CFG2 "B" | • | • | • | • | • | • | • | • | • | • | | |
| RF5/...-RFF5/... | • | • | • | • | • | • | • | • | • | • | | |
| RF170±290 | • 1) | • 1) | • 1) | • 1) | • 1) | • 1) | • 1) | • 1) | • 1) | • | | • |

- Ingresso standard / Standard input / Standardeingang / Entrée standard / Entrada standard / Entrada padrão (←)
 - Predisposizione RF / RF Setup / Auslegung RF / Préréglage RF / Predisposición RF / Predisposição RF
 - Predisposizione BOC / BOC Setup / Auslegung BOC / Préréglage BOC / Predisposición BOC / Predisposição BOC
- 1) Con / With / Mit / Avec / Con / Com **KIT CB01**

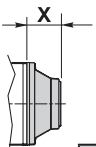

|  | SAI | | | | | | | | |
|---|------|---------------------------|------------------------------|--------------------------|-----------------------------|--------------------------|--------------|--------------------------|-------------------------------|
| | | GM05 28x34 UNI 8953 | GM05 35x2 z16 DIN 5480 | GM1 28x34 UNI 8953 | GM1 35x2 z16 DIN 5480 | GM2 36x40 UNI 8953 | | GM3 46x54 UNI 8953 | GM4/GM5A 56x65 UNI 8953 |
| | Code | 154-2300M455 | 154-2300M624 | 154-2300M43 | 154-2300M506 | 154-2300M549 | 154-2300M321 | 154-2300M838 | 154-2300M742 |
| X | 37 | 37 | 20 | 20 | 61 | 63.5 | 84 | 84 | |
| RR65 | | | | | | | | | |
| RR65D | | | | | | | | | |
| RR65T | | | | | | | | | |
| RR105 | • | • | • | • | • | | | | |
| RR105D | | | | | | | | | |
| RR105T | | | | | | | | | |
| RA105 | • | • | • | • | • | | | | |
| RA105D | • | • | • | • | • | | | | |
| RR110 | • | • | • | • | • | | | | |
| RR110D | | | | | | | | | |
| RR110T | | | | | | | | | |
| RA110 | • | • | • | • | • | | | | |
| RA110D | • | • | • | • | • | | | | |
| RR210 | • | • | • | • | • | | | | |
| RR210D | • | • | • | • | • | | | | |
| RR210T | | | | | | | | | |
| RR210Q | | | | | | | | | |
| RA210 | • | • | • | • | • | | | | |
| RA210D | • | • | • | • | • | | | | |
| RR310 | • | • | • | • | • | | | | |
| RR310D | • | • | • | • | • | | | | |
| RR310T | | | | | | | | | |
| RR310Q | | | | | | | | | |
| RA310 | • | • | • | • | • | | | | |
| RA310D | • | • | • | • | • | | | | |
| RA310T | • | • | • | • | • | | | | |
| RR510 | • | • | • | • | • | | | | |
| RR510D | • | • | • | • | • | | | | |
| RR510T | • | • | • | • | • | | | | |
| RR510Q | | | | | | | | | |
| RA510 | • | • | • | • | • | | | | |
| RA510D | • | • | • | • | • | | | | |
| RA510T | • | • | • | • | • | | | | |
| RR710 | • | • | • | • | • | | | | |
| RR710D | • | • | • | • | • | | | | |
| RR710T | • | • | • | • | • | | | | |
| RR710Q | | | | | | | | | |
| RA710 | • | • | • | • | • | | | | |
| RA710D | • | • | • | • | • | | | | |
| RA710T | • | • | • | • | • | | | | |
| RR810 | • 1) | • 1) | • 1) | • 1) | | • | • | • | |
| RR810D | • | • | • | • | | | | | |
| RR810T | • | • | • | • | | | | | |
| RR810Q | | | | | | | | | |
| RA810 | • | • | • | • | | | | | |
| RA810D | • | • | • | • | | | | | |
| RA810T | • | • | • | • | | | | | |
| RR1010 | • 1) | • 1) | • 1) | • 1) | | • | • | • | |
| RR1010D | • | • | • | • | | | | | |
| RR1010T | • | • | • | • | | | | | |
| RR1010Q | • | • | • | • | | | | | |
| RA1010 (A) | • | • | • | • | | | | | |
| RA1010 (B) | • 1) | • 1) | • 1) | • 1) | | • | • | • | |
| RA1010D | • | • | • | • | | | | | |
| RA1010T | • | • | • | • | | | | | |
| RR1700 | • 1) | • 1) | • 1) | • 1) | | • | • | • | |
| RR1700D | • | • | • | • | | | | | |
| RR1700T | • | • | • | • | | | | | |
| RR1700Q | • | • | • | • | | | | | |
| RA1700 (A) | • | • | • | • | | | | | |
| RA1700 (B) | • 1) | • 1) | • 1) | • 1) | | • | • | • | |
| RA1700D | • | • | • | • | | | | | |
| RA1700T | • | • | • | • | | | | | |
| RF2/... CFG2 "A" | | | | | | | | | |
| RF2/... CFG2 "B" | • | • | • | • | | | | | |
| RF5/...-RFF5/... | • | • | • | • | | | | | |
| RF170÷290 | • 1) | • 1) | • 1) | • 1) | | • | • | • | |

- Ingresso standard / Standard input / Standardeingang / Entrée standard / Entrada standard / Entrada padrão (—)
 - Predisposizione RF / RF Setup / Auslegung RF / Préréglage RF / Predisposición RF / Predisposição RF
 - Predisposizione BOC / BOC Setup / Auslegung BOC / Préréglage BOC / Predisposición BOC / Predisposição BOC
- 1) Con / With / Mit / Avec / Con / Com **KIT CB01**

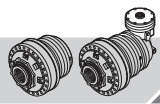

VOLVO (PARKER)

| X | VOLVO (PARKER) | | | | | | | | | | | | | | | | | | |
|------------------|----------------|---------------|-----------------------|---------------|---------------|------------------|---------------|----------------|---------------------|----------------|----------------|--------------------|---------------------|---------------|-------------------|---------------|---------------|---------------------|--------------|
| | F11-5 ø18 | F11-10 ø20 | F11-10 20x1,25 z14 | F11-19 ø25 | F11-28 ø25 | F11-39+58 ø35 | F11-78 ø45 | F11-110 ø45 | F11-110 40X2 Z18 | F11-150 ø50 | F11-150 ø50 | F11-150 45x2x21 | F11-250 8/16 Z15 | F12-30 ø30 | F12-40 ø1 1/4" | F12-60 ø35 | F12-80 ø40 | F12-80 12/24 Z17 | |
| | Code | 154-2300M11 | 154-2300M10 | 154-2300M338 | 154-2300M13 | 154-2300M14 | 154-2300M12 | 154-2300M129 | 154-2300M131 | 154-2300M363 | 154-2300M132 | 154-2300M473 | 154-2300M854 | 154-2300M591 | 154-2300M483 | 154-2300M594 | 154-2300M612 | 154-2300M481 | 154-2300M658 |
| X | 24 | 30 | 22 | 38 | 24 | 62 | 110 | 110 | 64 | 117 | 173 | 120 | 121 | 46 | 46 | 62 | 103 | 31.5 | |
| RR65 | | | • | | | | | | | | | | | | | | | | |
| RR65D | | | • | | | | | | | | | | | | | | | | |
| RR65T | | | • | | | | | | | | | | | | | | | | |
| RR105 | • | • | | • | • | • | | | • | | • | • | • | • | | | | | • |
| RR105D | | | • | | | | | | | | | | | | | | | | |
| RR105T | | | • | | | | | | | | | | | | | | | | |
| RA105 | • | • | | • | • | • | | | | • | • | • | • | • | | | | | • |
| RA105D | • | • | | • | • | • | | | | • | • | • | • | • | | | | | • |
| RR110 | • | • | | • | • | • | | | • | | • | • | • | • | | | | | • |
| RR110D | | | • | | | | | | | | | | | | | | | | |
| RR110T | | | • | | | | | | | | | | | | | | | | |
| RA110 | • | • | | • | • | • | | | | • | • | • | • | • | | | | | • |
| RA110D | • | • | | • | • | • | | | | • | • | • | • | • | | | | | • |
| RR210 | • | • | | • | • | • | | | | | | | | | | | | | • |
| RR210D | • | • | | • | • | • | | | | | | | | | | | | | • |
| RR210T | | | | | | | | | | | | | | | | | | | |
| RR210Q | | | • | | | | | | | | | | | | | | | | |
| RA210 | • | • | | • | • | • | | | | | | | | | | | | | • |
| RA210D | • | • | | • | • | • | | | | | | | | | | | | | • |
| RR310 | • | • | | • | • | • | ○ | ○ | • | | | | | | | | | ○ | • |
| RR310D | • | • | | • | • | • | | | • | | | | | | | | | | • |
| RR310T | | | • | | | | | | | | | | | | | | | | |
| RR310Q | | | • | | | | | | | | | | | | | | | | |
| RA310 | • | • | | • | • | • | | | | • | • | • | • | • | | | | | • |
| RA310D | • | • | | • | • | • | | | | • | • | • | • | • | | | | | • |
| RA310T | • | • | | • | • | • | | | | • | • | • | • | • | | | | | • |
| RR510 | • | • | | • | • | • | ○ | ○ | • | | | | | | | | | | • |
| RR510D | • | • | | • | • | • | ○ | ○ | • | | | | | | | | | ○ | • |
| RR510T | • | • | | • | • | • | | | • | | | | | | | | | | • |
| RR510Q | | | • | | | | | | | | | | | | | | | | |
| RA510 | • | • | | • | • | • | | | | • | • | • | • | • | | | | | • |
| RA510D | • | • | | • | • | • | | | | • | • | • | • | • | | | | | • |
| RA510T | • | • | | • | • | • | | | | • | • | • | • | • | | | | | • |
| RR710 | • | • | | • | • | • | ○ | ○ | • | | | | | | | | | ○ | • |
| RR710D | • | • | | • | • | • | ○ | ○ | • | | | | | | | | | ○ | • |
| RR710T | • | • | | • | • | • | | | • | | | | | | | | | | • |
| RR710Q | | | • | | | | | | | | | | | | | | | | |
| RA710 | • | • | | • | • | • | | | | • | • | • | • | • | | | | | • |
| RA710D | • | • | | • | • | • | | | | • | • | • | • | • | | | | | • |
| RA710T | • | • | | • | • | • | | | | • | • | • | • | • | | | | | • |
| RR810 | • 1) | • 1) | | • 1) | • 1) | • 1) | | | • 1) | • | | • 1) | • 1) | • 1) | | | | | • 1) |
| RR810D | • | • | | • | • | • | ○ | ○ | • | | | • | • | • | | | | ○ | • |
| RR810T | • | • | | • | • | • | | | • | | | • | • | • | | | | | • |
| RR810Q | | | • | | | | | | | | | | | | | | | | |
| RA810 | • | • | | • | • | • | | | | • | • | • | • | • | | | | | • |
| RA810D | • | • | | • | • | • | | | | • | • | • | • | • | | | | | • |
| RA810T | • | • | | • | • | • | | | | • | • | • | • | • | | | | | • |
| RR1010 | • 1) | • 1) | | • 1) | • 1) | • 1) | | | • 1) | • | | • 1) | • 1) | • 1) | | | | | • 1) |
| RR1010D | • | • | | • | • | • | ○ | ○ | • | | | • | • | • | | | | ○ | • |
| RR1010T | • | • | | • | • | • | ○ | ○ | • | | | • | • | • | | | | ○ | • |
| RR1010Q | • | • | | • | • | • | | | | | | | | | | | | | |
| RA1010 (A) | • | • | | • | • | • | | | | • | • | • | • | • | | | | | • |
| RA1010 (B) | • 1) | • 1) | | • 1) | • 1) | • 1) | | | • 1) | • | | • 1) | • 1) | • 1) | | | | | • 1) |
| RA1010D | • | • | | • | • | • | | | | • | • | • | • | • | | | | | • |
| RA1010T | • | • | | • | • | • | | | | • | • | • | • | • | | | | | • |
| RR1700 | • 1) | • 1) | | • 1) | • 1) | • 1) | | | • 1) | • | | • 1) | • 1) | • 1) | | | | | • 1) |
| RR1700D | • | • | | • | • | • | ○ | ○ | • | | | • | • | • | | | | ○ | • |
| RR1700T | • | • | | • | • | • | ○ | ○ | • | | | • | • | • | | | | ○ | • |
| RR1700Q | • | • | | • | • | • | | | | | | | | | | | | | |
| RA1700 (A) | • | • | | • | • | • | | | | • | • | • | • | • | | | | | • |
| RA1700 (B) | • 1) | • 1) | | • 1) | • 1) | • 1) | | | • 1) | • | | • 1) | • 1) | • 1) | | | | | • 1) |
| RA1700D | • | • | | • | • | • | | | | • | • | • | • | • | | | | | • |
| RA1700T | • | • | | • | • | • | | | | • | • | • | • | • | | | | | • |
| RF2/... CFG2 "A" | | | • | | | | | | | | | | | | | | | | |
| RF2/... CFG2 "B" | • | • | | • | • | • | | | • | | | • | • | • | | | | | • |
| RF5/...-RFF5/... | • | • | | • | • | • | | | • | | | • | • | • | | | | | • |
| RF170+290 | • 1) | • 1) | | • 1) | • 1) | • 1) | | | • 1) | • | | • 1) | • 1) | • 1) | | | | | • 1) |

- Ingresso standard / Standard input / Standardeingang / Entrée standard / Entrada standard / Entrada padrão (—)
- Predisposizione RF / RF Setup / Auslegung RF / Préréglage RF / Predisposición RF / Predisposição RF
- Predisposizione BOC / BOC Setup / Auslegung BOC / Préréglage BOC / Predisposición BOC / Predisposição BOC
- 1) Con / With / Mit / Avec / Con / Com **KIT CB01**

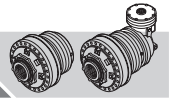

| | | IEC B5 | | | | | | | | | | | | | | | | | | | | | | | | | | |
|---|------|--------------|--------------|--------------|--------------|--------------|--------------|--------------|--------------|--------------|--------------|--------------|--------------|--------------|--------------|--------------|--------------|--------------|--------------|--------------|--------------|--------------|--------------|--------------|--------------|--------------|--------------|---|
| | | 63 | | 71 | | 80 | | 90 | | 100-112 | | | 132 | | 160 | | 180 | | 200 | | 225 | | | | | | | |
|  | Code | 154-2300M497 | 154-2300M367 | 154-2300M341 | 154-2300M228 | 154-2300M229 | 154-2300M532 | 154-2300M230 | 154-2300M520 | 154-2300M231 | 154-2300M518 | 154-2300M584 | 154-2300M607 | 154-2300M232 | 154-2300M582 | 154-2300M585 | 154-2300M606 | 154-2300M456 | 154-2300M586 | 154-2300M235 | 154-2300M595 | 154-2300M744 | 154-2300M721 | 154-2300M442 | 154-2300M535 | 154-2300M496 | 154-2300M748 | |
| | X | 24 | 18.5 | 18 | 18 | 24 | 32.5 | 24 | 32.5 | 30 | 32.5 | 52 | 52 | 97 | 62.5 | 75.5 | 75.5 | 128 | 105 | 128 | 105 | 115 | 142 | 142 | 162 | 134 | 191 | |
| RR65 | • | | | | | | | | | | | | | | | | | | | | | | | | | | | |
| RR65D | • | | | | | | | | | | | | | | | | | | | | | | | | | | | |
| RR65T | • | | | | | | | | | | | | | | | | | | | | | | | | | | | |
| RR105 | • | • | | • | | | ■ | | | ■ | | | | | ■ | | | | • | | | • | | | | | | |
| RR105D | • | | | • | | | | | | | | | | | | | | | | | | | | | | | | |
| RR105T | • | | | • | | | | | | | | | | | | | | | | | | | | | | | | |
| RA105 | | • | | | • | • | | | • | | | | | • | | | | | • | | • | | | | | | | |
| RA105D | | | | | • | • | | | • | | | | | • | | | | | • | | • | | | | | | | |
| RR110 | | • | | | • | | ■ | | | ■ | | | | | ■ | | | | • | | | • | | | | | | |
| RR110D | • | | | • | | | | | | | | | | | | | | | | | | | | | | | | |
| RR110T | • | | | • | | | | | | | | | | | | | | | | | | | | | | | | |
| RA110 | | • | | | • | • | | | • | | | | | • | | | | | • | | • | | | | | | | |
| RA110D | | • | | | • | • | | | • | | | | | • | | | | | • | | • | | | | | | | |
| RR210 | | • | | | • | | ■ | | | ■ | | | | | ■ | | | | • | | | • | | | | | | |
| RR210D | | • | | | • | | | | | | | | | | | | | | | | | | | | | | | |
| RR210T | | • | | | • | | | | | | | | | | | | | | | | | | | | | | | |
| RR210Q | • | | | • | | | | | | | | | | | | | | | | | | | | | | | | |
| RA210 | | • | | | • | • | | | • | | | | | • | | | | | • | | • | | | | | | | |
| RA210D | | • | | | • | • | | | • | | | | | • | | | | | • | | • | | | | | | | |
| RR310 | | • | | | • | • | | | • | | | ■ | | | | ■ | | | | • | | ■ | | | | | | |
| RR310D | | • | | | • | • | | | • | | | | | | | | | | | | | | | | | | | |
| RR310T | • | | | • | | | | | | | | | | | | | | | | | | | | | | | | |
| RR310Q | • | | | • | | | | | | | | | | | | | | | | | | | | | | | | |
| RA310 | | • | | | • | • | | | • | | | | | • | | | | | • | | • | | | | | | | |
| RA310D | | • | | | • | • | | | • | | | | | • | | | | | • | | • | | | | | | | |
| RA310T | | • | | | • | • | | | • | | | | | • | | | | | • | | • | | | | | | | |
| RR510 | | • | | | • | • | | | • | | | | | | ■ | | ■ | | | ■ | | ■ | | | | | | |
| RR510D | | • | | | • | • | | | • | | | | | | | | | | | | | | | | | | | |
| RR510T | | • | | | • | • | | | ■ | | | | | | ■ | | ■ | | | • | | ■ | | | | | | |
| RR510Q | • | | | • | | | | | | | | | | | | | | | | | | | | | | | | |
| RA510 | | • | | | • | • | | | • | | | | | • | | | | | • | | • | | | | | | ■ | ■ |
| RA510D | | • | | | • | • | | | • | | | | | • | | | | | • | | • | | | | | | | |
| RA510T | | • | | | • | • | | | • | | | | | • | | | | | • | | • | | | | | | | |
| RR710 | | • | | | • | • | | | • | | | | | ■ | | ■ | | | | ■ | | ■ | | | | | | |
| RR710D | | • | | | • | • | | | • | | | | | | | | | | | | | | | | | | | |
| RR710T | | • | | | • | • | | | ■ | | | | | ■ | | ■ | | | • | | • | | | | | | | |
| RR710Q | • | | | • | | | | | | | | | | | | | | | | | | | | | | | | |
| RA710 | | • | | | • | • | | | • | | | | | • | | | | | • | | • | | | | | | ■ | ■ |
| RA710D | | • | | | • | • | | | • | | | | | • | | | | | • | | • | | | | | | | |
| RA710T | | • | | | • | • | | | • | | | | | • | | | | | • | | • | | | | | | | |
| RR810 | • 1) | • 1) | • 1) | • 1) | | | | • 1) | | • 1) | | | | • 1) | | | | | • 1) | | | | • | ■ | | | • | |
| RR810D | • | | | • | | | | • | | | | | | ■ | | ■ | | | | ■ | | ■ | | | | | | |
| RR810T | • | | | • | | | | ■ | | ■ | | | | | ■ | | ■ | | | • | | • | | | | | | |
| RR810Q | • | | | • | | | | | | | | | | | | | | | | | | | | | | | | |
| RA810 | | • | | | • | • | | | • | | | | | • | | | | | • | | • | | | | | | ■ | ■ |
| RA810D | | • | | | • | • | | | • | | | | | • | | | | | • | | • | | | | | | | |
| RA810T | | • | | | • | • | | | • | | | | | • | | | | | • | | • | | | | | | | |
| RR1010 | • 1) | • 1) | • 1) | • 1) | | | | • 1) | | • 1) | | | | • 1) | | | | | • 1) | | | | • | | | ■ | | • |
| RR1010D | • | | | • | | | | • | | | | | | | | | | | | | | | | | | | | |
| RR1010T | • | | | • | | | | • | | | | | | | | | | | | | | | | | | | | |
| RR1010Q | • | | | • | | | | ■ | | ■ | | | | | ■ | | ■ | | | | | | | | | | | |
| RA1010 (A) | • | | | • | | | | • | | • | | | | • | | | | | • | | • | | | | | | ■ | ■ |
| RA1010 (B) | • 1) | • 1) | • 1) | • 1) | | | | • 1) | | • 1) | | | | • 1) | | | | | • 1) | | • | | | | | | ■ | ■ |
| RA1010D | • | | | • | | | | • | | | | | | • | | | | | • | | • | | | | | | ■ | ■ |
| RA1010T | • | | | • | | | | • | | | | | | • | | | | | • | | • | | | | | | | |
| RR1700 | • 1) | • 1) | • 1) | • 1) | | | | • 1) | | • 1) | | | | • 1) | | | | | • 1) | | | | • | | | | • | |
| RR1700D | • | | | • | | | | • | | | | | | ■ | | ■ | | | | ■ | | ■ | | | | | | |
| RR1700T | • | | | • | | | | • | | | | | | | | | | | | | | | | | | | | |
| RR1700Q | • | | | • | | | | ■ | | ■ | | | | | | | | | • | | • | | | | | | | |
| RA1700 (A) | • | | | • | | | | • | | • | | | | • | | | | | • | | • | | | | | | ■ | ■ |
| RA1700 (B) | • 1) | • 1) | • 1) | • 1) | | | | • 1) | | • 1) | | | | • 1) | | | | | • 1) | | | | • | | | | ■ | ■ |
| RA1700D | • | | | • | | | | • | | | | | | • | | | | | • | | • | | | | | | ■ | ■ |
| RA1700T | • | | | • | | | | • | | | | | | • | | | | | • | | • | | | | | | ■ | ■ |
| RF2/... CFG2 "A" | | | | | | | | | | | | | | | | | | | | | | | | | | | | |
| RF2/... CFG2 "B" | | | | | | | | | | | | | | | | | | | | | | | | | | | | |
| RF5/...-RFF5/... | | | | | | | | | | | | | | | | | | | | | | | | | | | | |
| RF170÷290 | | | | | | | | | | | | | | | | | | | | | | | | | | | | |

• Ingresso standard / Standard input / Standardeingang / Entrée standard / Entrada standard / Entrada padrão (—)
 ■ Predisposizione RF / RF Setup / Auslegung RF / Préréglage RF / Predisposición RF / Predisposição RF
 ○ Predisposizione BOC / BOC Setup / Auslegung BOC / Préréglage BOC / Predisposición BOC / Predisposição BOC
 1) Con / With / Mit / Avec / Con / Com **KIT CB01**

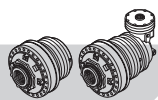
13 NORME PER L'INSTALLAZIONE
13 INSTALLATION INSTRUCTIONS
13 INSTALLATIONSVORSCHRIFTEN
13.1 Dimensioni suggerite per il montaggio

Montare il riduttore, fissandolo alla struttura nei punti previsti. Un accorgimento molto importante, al fine di evitare che le flange di sostegno dei riduttori vengano messe in tensione già in fase di montaggio, consiste nell'assicurarsi che la controflangia di fissaggio aderisca perfettamente alla flangia del riduttore. Controllare il corretto allineamento tra l'albero del riduttore (sia in versione maschio sia in versione femmina) e il controalbero calettato (manicotto, giunto, albero scanalato, etc.) per evitare il deterioramento dei profili scanalati.

Serrare le viti di fissaggio in base alle dimensioni e alla classe di appartenenza, secondo i valori riportati nella tabella seguente; il precarico indicato è pari al 70% del carico di snervamento minimo, con un coefficiente di attrito medio pari a 0.14.

Si raccomanda di utilizzare viti in classe 10.9 o 12.9 laddove l'applicazione preveda forti urti, frequenti arresti, avvii e/o inversioni del moto, o quando si supera il 70% della coppia massima ammissibile.

13.1 Recommended dimensions for assembly

Mount the reduction gear, fixing it to the structure in the right points. It is very important to prevent the reduction gears' supporting flanges from being tensioned during assembly: to do this make sure the counter-flange for fastening adheres perfectly to the reduction gear flange. Check both in the male and female versions that the alignment between the reduction gear shaft and the splined countershaft is correct (sleeve, joint, splined shaft, etc.) to avoid deterioration of the splined profiles.

Tighten the securing screws based on the dimensions and class according to the values given in the following table; the preload has been calculated as 70% of the minimum yield strength with an average friction coefficient of 0.14.

Use either 10.9 or 12.9 class screws if the application entails significant knocks, frequent stops, starts and/or reversal of direction or when 70% of the maximum permitted torque is exceeded.

13.1 Empfohlene Abmessungen für die Montage

Montieren Sie die Untersetzung und befestigen Sie sie an den vorgesehenen Punkten. Stellen Sie sicher, dass der Gegenflansch der Befestigung perfekt am Flansch der Untersetzung anliegt; dies ist eine sehr wichtige Maßnahme, um zu vermeiden, dass die Halterungsflansche der Untersetzungen bereits in der Phase der Montage Spannungen ausgesetzt werden.

Überprüfen Sie die richtige Ausrichtung der Welle der Untersetzung (sowohl in der Version mit Welle, als auch in der Version mit Einsatz) und der Gegenkeilwelle (Muffe, Kupplung, Keilwelle usw.), um eine Abnutzung der Keilprofile zu vermeiden. Ziehen Sie die Befestigungsschrauben unter Beachtung der Abmessungen und der Zugehörigkeitsklassen mit den in der folgenden Tabelle angegebenen Werten an; die angegebene Vorspannung entspricht 70% der min. Verwindungslast; dabei wurde für den Reibungskoeffizienten ein durchschnittlicher Wert von 0.14 angesetzt.

Wir empfehlen die Verwendung von Schrauben der Klasse 10.9 oder 12.9, falls die Anwendung starke Stöße, ein häufiges Anhalten und/oder häufige Richtungswechsel vorsieht oder wenn 70% des max. zulässigen Drehmoments überschritten werden.

| Diametro vite Screw diameter Schraubendurchmesser | Precarico max [kg] Max. preload [kg] Max. Vorspannung [kg] | | | Coppia max [daNm] Max. torque [daNm] Max. Anzugsmoment [daNm] | | |
|---|--|-------|-------|---|--------|--------|
| | 8.8 | 10.9 | 12.9 | 8.8 | 10.9 | 12.9 |
| | 8G | 10K | 12k | 8G | 10K | 12K |
| M4 | 394 | 554 | 665 | 0.31 | 0.43 | 0.52 |
| M5 | 635 | 895 | 1070 | 0.60 | 0.84 | 1.01 |
| M6 | 902 | 1270 | 1520 | 1.03 | 1.46 | 1.75 |
| M7 | 1300 | 1820 | 2180 | 1.69 | 2.36 | 2.83 |
| M8 | 1640 | 2310 | 2770 | 2.48 | 3.49 | 4.19 |
| M9 | 2160 | 3050 | 3630 | 3.67 | 5.18 | 6.17 |
| M10 | 2600 | 3660 | 4380 | 4.97 | 7.00 | 8.37 |
| M12 | 3780 | 5320 | 6380 | 8.46 | 11.90 | 14.30 |
| M14 | 5160 | 7250 | 8700 | 13.46 | 18.92 | 22.70 |
| M16 | 7020 | 9900 | 11900 | 20.40 | 28.80 | 34.60 |
| M18 | 8600 | 12100 | 14500 | 28.40 | 40.00 | 48.00 |
| M20 | 11000 | 15540 | 18500 | 39.60 | 55.60 | 66.60 |
| M22 | 13600 | 19100 | 22900 | 53.00 | 74.50 | 90.00 |
| M24 | 15900 | 22300 | 26700 | 70.00 | 98.00 | 117.00 |
| M27 | 20600 | 28900 | 34700 | 101.00 | 142.00 | 170.00 |
| M30 | 28000 | 39900 | 46700 | 150.00 | 213.00 | 250.00 |

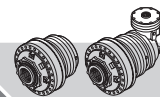
**13.1 Dimensions recommandées pour le montage**

Monter le réducteur en le fixant à la structure aux endroits prévus. Il existe une astuce très importante qui permet d'éviter que les brides de support des réducteurs ne soient mises sous tension dès la phase de montage, et qui consiste à s'assurer que la contre-bride adhère parfaitement à la bride du réducteur.

Contrôler l'alignement correct entre l'arbre du réducteur, aussi bien dans les variantes mâle que femelle, et le contre-arbre emboîté (manchon, joint, arbre cannelé, etc.) pour éviter que les profils cannelés ne se détériorent.

Serrer les vis de fixation en fonction des dimensions et de la classe d'appartenance, suivant les valeurs qui figurent sur le tableau suivant; le pré-chargement indiqué a été calculé à 70 % du chargement de la limite d'élasticité minimum et en attribuant au coefficient de frottement la valeur moyenne de 0.14.

Nous recommandons d'utiliser des vis en classe 10.9 ou 12.9 si l'application est destinée à subir des chocs importants, des arrêts fréquents, des démarrages et/ou des inversions de mouvement ou quand le couple maximum admissible dépasse 70 %.

13.1 Dimensiones sugeridas para el montaje

Montar el reductor, fijándolo a la estructura en los puntos previstos. Algo muy importante a tener en cuenta para evitar que las bridas de sostén de los reductores sean puestas en tensión ya en la fase de montaje, consiste en comprobar que la contrabrida de fijación adhiera perfectamente a la brida del reductor. Comprobar la correcta alineación entre el eje del reductor (tanto en versión macho como en versión hembra) y el contra-eje ensamblado (manguito, junta, eje acanalado, etc.) para evitar que se deterioren los perfiles acanalados.

Apretar los tornillos de sujeción según las dimensiones y la clase de pertenencia, conforme a los valores indicados en la tabla siguiente; la precarga indicada es del 70% de la carga de fluencia mínima, con un coeficiente medio de fricción de 0.14.

Se recomienda utilizar tornillos de clase 10.9 ó 12.9 cuando la aplicación prevea fuertes golpes, frecuentes paradas, arranques y/o inversiones de la marcha, o cuando se supere el 70% del par máximo admitido.

13.1 Dimensões sugeridas para a montagem

Monter o redutor, fixando-o à estrutura nos pontos previstos. Uma precaução muito importante, para evitar que as flanges de suporte dos redutores sejam colocadas em tensão já em fase de montagem, consiste em assegurar que a contra-flange de fixação adira perfeitamente à flange do redutor. Verificar o alinhamento correcto entre o eixo do redutor (seja em versão macho seja em versão fêmea) e o contra-eixo ajustado (luva, junta, eixo ranhurado, etc.) para evitar a deterioração dos perfis ranhurados.

Apertar os parafusos de fixação com base nas dimensões e na classe de pertença, segundo os valores indicados na tabela a seguir; a pré-carga indicada corresponde a 70% da carga de deformação plástica mínima, com um coeficiente de atrito médio igual a 0.14.

Recomenda-se utilizar parafusos de classe 10.9 ou 12.0 caso a aplicação preveja fortes choques, paragens frequentes, arranques e/ou inversões do movimento ou quando é ultrapassado 70% do par máximo admissível.

| Diamètre de la vis Diámetro tornillo Diâmetro parafuso | Préchargement max. [kg] Precarga max. [kg] Pré-carga máx. [kg] | | | Couple max [daNm] Par máx. [daNm] Par máx. [daNm] | | |
|--|--|-------|-------|---|--------|--------|
| | 8.8 | 10.9 | 12.9 | 8.8 | 10.9 | 12.9 |
| | 8G | 10K | 12k | 8G | 10K | 12K |
| M4 | 394 | 554 | 665 | 0.31 | 0.43 | 0.52 |
| M5 | 635 | 895 | 1070 | 0.60 | 0.84 | 1.01 |
| M6 | 902 | 1270 | 1520 | 1.03 | 1.46 | 1.75 |
| M7 | 1300 | 1820 | 2180 | 1.69 | 2.36 | 2.83 |
| M8 | 1640 | 2310 | 2770 | 2.48 | 3.49 | 4.19 |
| M9 | 2160 | 3050 | 3630 | 3.67 | 5.18 | 6.17 |
| M10 | 2600 | 3660 | 4380 | 4.97 | 7.00 | 8.37 |
| M12 | 3780 | 5320 | 6380 | 8.46 | 11.90 | 14.30 |
| M14 | 5160 | 7250 | 8700 | 13.46 | 18.92 | 22.70 |
| M16 | 7020 | 9900 | 11900 | 20.40 | 28.80 | 34.60 |
| M18 | 8600 | 12100 | 14500 | 28.40 | 40.00 | 48.00 |
| M20 | 11000 | 15540 | 18500 | 39.60 | 55.60 | 66.60 |
| M22 | 13600 | 19100 | 22900 | 53.00 | 74.50 | 90.00 |
| M24 | 15900 | 22300 | 26700 | 70.00 | 98.00 | 117.00 |
| M27 | 20600 | 28900 | 34700 | 101.00 | 142.00 | 170.00 |
| M30 | 28000 | 39900 | 46700 | 150.00 | 213.00 | 250.00 |

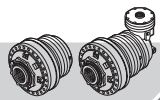

Nel montaggio di riduttori femmina predisporre l'albero scanalato di accoppiamento al riduttore con tolleranza (e9). Prevedere, inoltre, i fori per alloggiare le spine; nelle figure che seguono sono indicati i valori consigliati per le sporgenze dal piano di appoggio.

When mounting the female reduction gears, place the splined coupling shaft with the reduction gear with tolerance (e9). In addition, provide holes for housing the pins; the recommended supporting surface overhangs are shown in the following figures.

Verwenden Sie bei der Kupplung von Innenuntersetzungen die Keilwelle mit Toleranz (e9). Bereiten Sie außerdem die Bohrungen für die Aufnahme der Stifte vor; auf den folgenden Abbildungen werden die empfohlenen Werte für Überstände über die Auflagefläche angegeben.

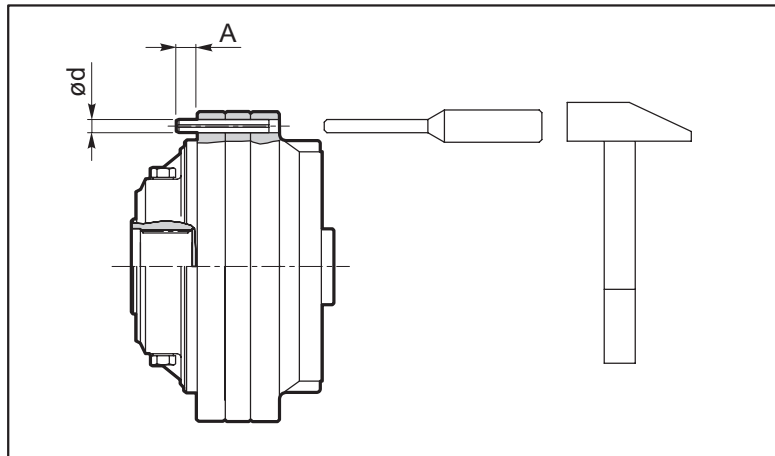
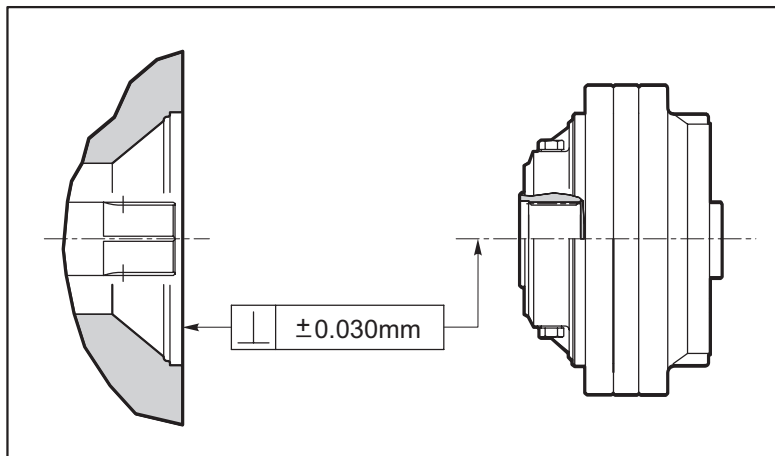

| Tipo Type Typ | | ød | A |
|---|----------------------|----|----|
| RR310 RR310D RR310T RR310Q | FS FS FS FS | 10 | 14 |
| RR510 RR510D RR510T RR510Q | FS FS FS FS | 10 | 14 |
| RR710 RR710D RR710T RR710Q | FS FS FS FS | 10 | 14 |
| RR810 RR810D RR810T RR810Q | FS FS FS FS | 12 | 14 |
| RR1010 RR1010D RR1010T RR1010Q | FS FS FS FS | 12 | 13 |
| RR1700 RR1700D RR1700T RR1700Q | FS FS FS FS | 12 | 13 |

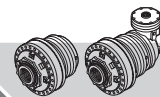

FR ES PT

Dans le montage des réducteurs femelle, disposer l'arbre cannelé d'accouplement au réducteur avec tolérance (e9). Il faut aussi prévoir les trous pour loger les chevilles; les figures suivantes montrent les valeurs recommandées pour les saillies du plan d'appui.

Para el montaje de reductores hembra predisponer el eje acanalado de acoplamiento con el reductor con tolerancia (e9).

Prever, además, los agujeros para alojar las clavijas; en las figuras siguientes se indican los valores aconsejados para las salientes respecto al plano de apoyo.

No montagem de reductores fêmea preparar o eixo ranhurado de acoplamento ao redutor com tolerância (e9). Prever ainda os orifícios para alojar as fichas; nas figuras a seguir estão indicados os valores aconselhados para as saliências do plano de apoio.

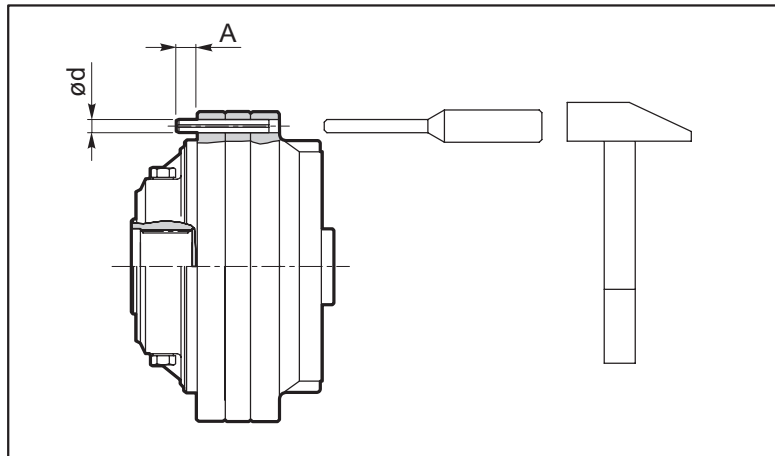
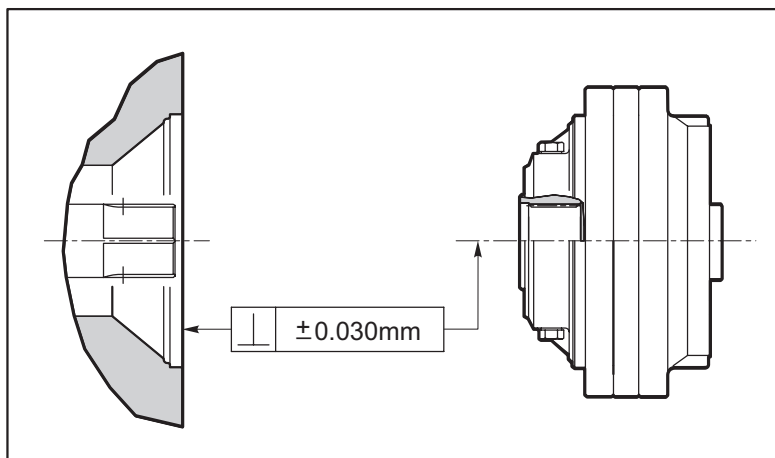

| Type Tipo Tipo | | ød | A |
|----------------------|----|----|----|
| RR310 | FS | 10 | 14 |
| RR310D | FS | | |
| RR310T | FS | | |
| RR310Q | FS | | |
| RR510 | FS | 10 | 14 |
| RR510D | FS | | |
| RR510T | FS | | |
| RR510Q | FS | | |
| RR710 | FS | 10 | 14 |
| RR710D | FS | | |
| RR710T | FS | | |
| RR710Q | FS | | |
| RR810 | FS | 12 | 14 |
| RR810D | FS | | |
| RR810T | FS | | |
| RR810Q | FS | | |
| RR1010 | FS | 12 | 13 |
| RR1010D | FS | | |
| RR1010T | FS | | |
| RR1010Q | FS | | |
| RR1700 | FS | 12 | 13 |
| RR1700D | FS | | |
| RR1700T | FS | | |
| RR1700Q | FS | | |

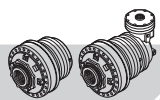

Di seguito sono indicate le dimensioni suggerite per il montaggio dei riduttori per rotazione VI e ZI alla macchina.

The recommended dimensions are given below for assembling the reduction gears for VI and ZI rotation with respect to the machine.

Im Folgenden sind die empfohlenen Abmessungen für die Montage der Drehantriebe VI und ZI an die Maschine angegeben.

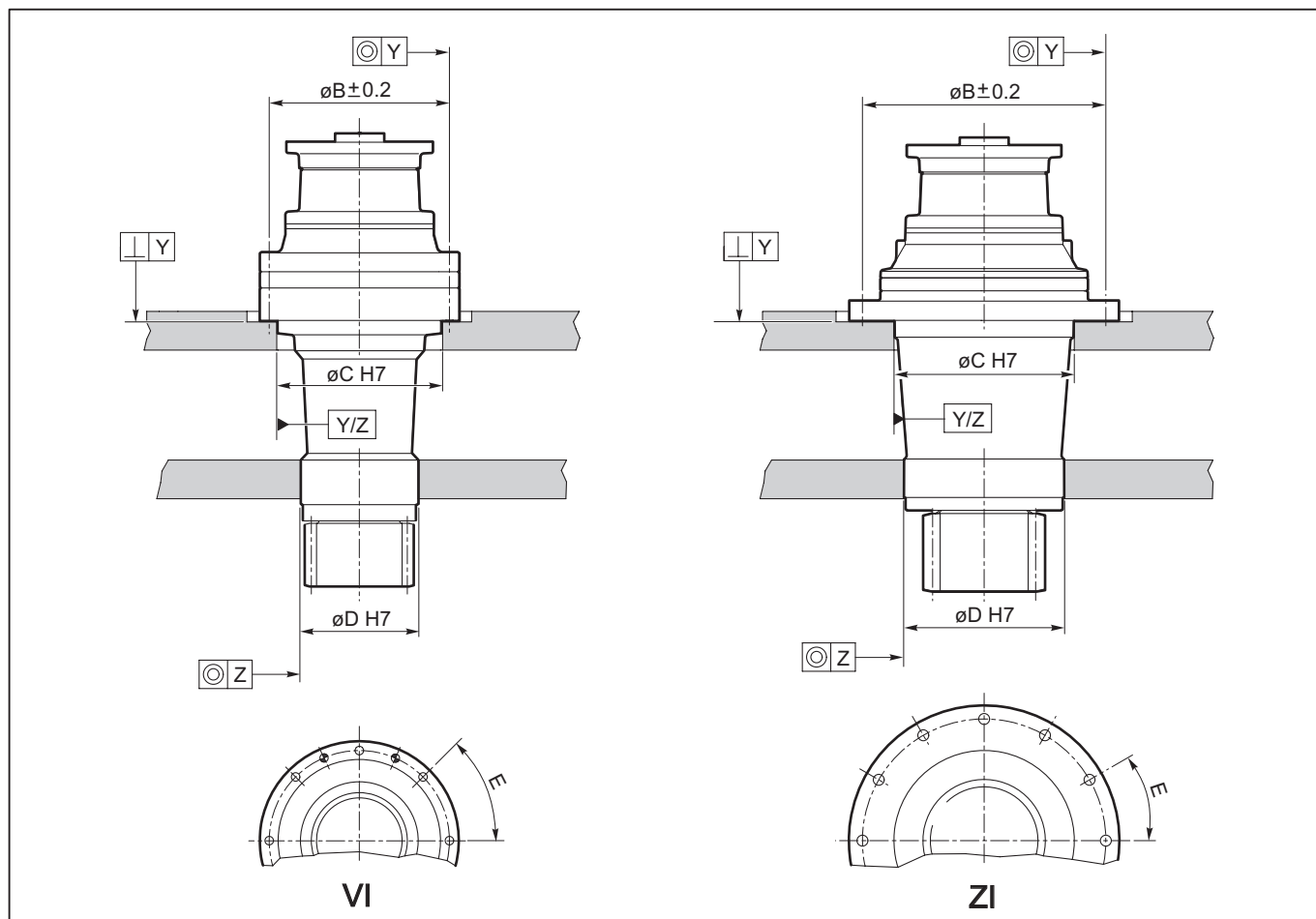

| Tipo Type Typ | B | C | D | E | $\odot Y$ | $\perp Y$ | $\odot Z$ |
|------------------------|-----|-----|-----|--------------------|-----------|-----------|-----------|
| RR510 VI RR710 VI | 222 | 200 | 145 | $45^\circ \pm 10'$ | 0.3 | 0.05 | 0.05 |
| RR810 VI | 275 | 250 | 200 | $45^\circ \pm 10'$ | 0.3 | 0.05 | 0.05 |
| RR1010 VI | 299 | 280 | 250 | $45^\circ \pm 10'$ | 0.3 | 0.05 | 0.1 |
| RR1700 VI | 314 | 280 | 250 | $30^\circ \pm 8'$ | 0.3 | 0.05 | 0.1 |
| RR810 ZI | 325 | 250 | 200 | $36^\circ \pm 10'$ | 0.3 | 0.05 | 0.1 |
| RR1010 ZI RR1700 ZI | 380 | 280 | 250 | $30^\circ \pm 8'$ | 0.3 | 0.05 | 0.1 |

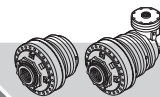

FR ES PT

Ci-après figurent les dimensions suggérées pour le montage des réducteurs pour rotation VI et ZI à la machine.

A continuación se indican las medidas sugeridas para el montaje de los reductores para rotación VI y ZI en la máquina.

A seguir estão indicadas as dimensões aconselhadas para a montagem dos reductores para rotação VI e ZI à máquina.

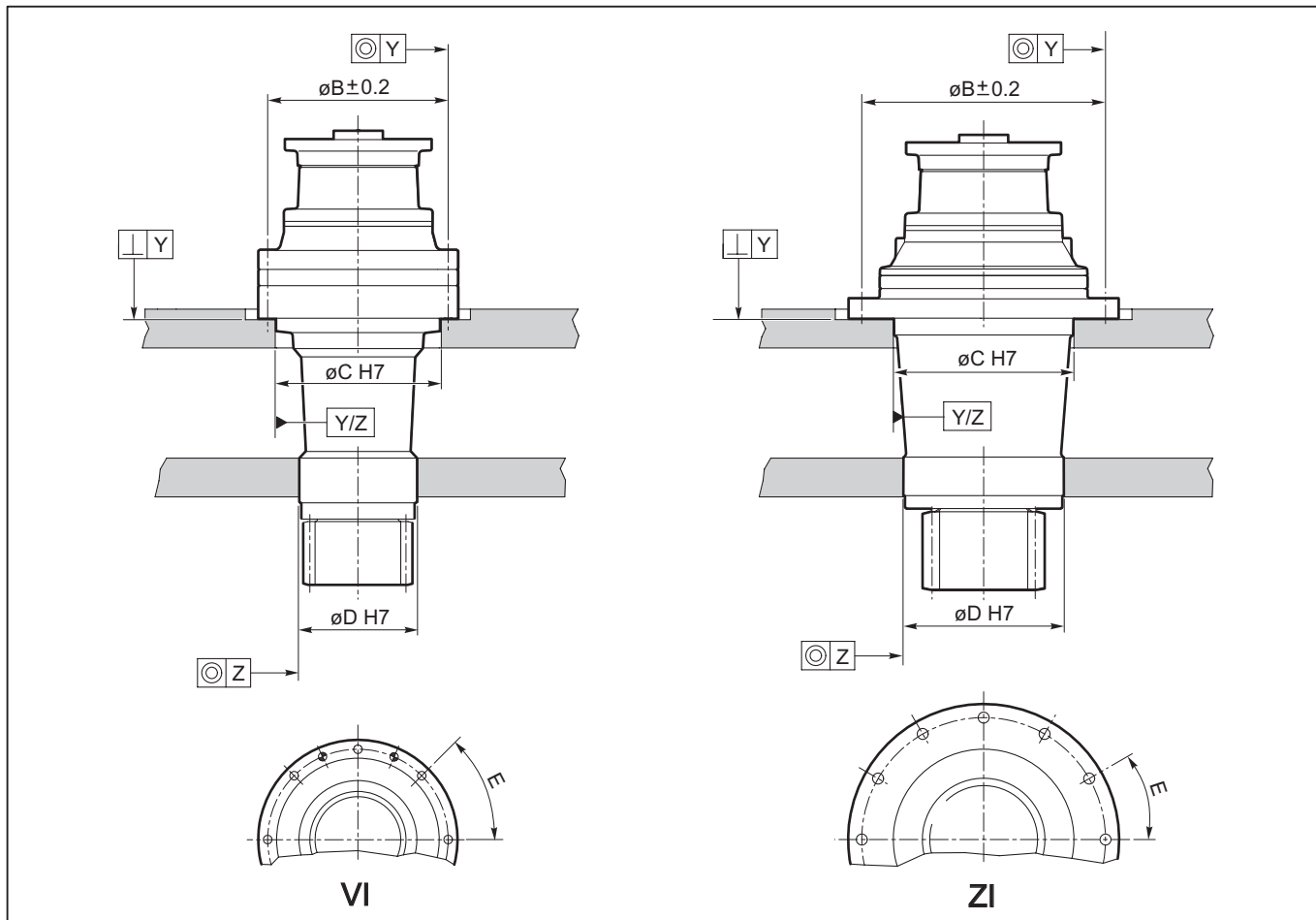

| Type Tipo Tipo | B | C | D | E | | | |
|------------------------|-----|-----|-----|-----------|-----|------|------|
| RR510 VI RR710 VI | 222 | 200 | 145 | 45° ± 10' | 0.3 | 0.05 | 0.05 |
| RR810 VI | 275 | 250 | 200 | 45° ± 10' | 0.3 | 0.05 | 0.05 |
| RR1010 VI | 299 | 280 | 250 | 45° ± 10' | 0.3 | 0.05 | 0.1 |
| RR1700 VI | 314 | 280 | 250 | 30° ± 8' | 0.3 | 0.05 | 0.1 |
| RR810 ZI | 325 | 250 | 200 | 36° ± 10' | 0.3 | 0.05 | 0.1 |
| RR1010 ZI RR1700 ZI | 380 | 280 | 250 | 30° ± 8' | 0.3 | 0.05 | 0.1 |

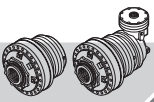

13.2 Calettatori per attrito

13.2 Friction shrink discs

13.2 Schrumpfscheiben

Prima di procedere con il montaggio del calettatore per attrito, occorre pulire e sgrassare accuratamente le superfici indicate con \triangle , cioè la superficie di centraggio dell'albero (1a) e la superficie interna del mozzo (1b). Inoltre occorre pulire ed oliare leggermente la superficie interna del calettatore (2a) e la superficie esterna del mozzo (2b), facendo in modo che l'olio non raggiunga le superfici già pulite e sgrassate (1a e 1b).

Before starting to mount the friction shrink disc, the surfaces indicated with \triangle , that is the shaft centring surface (1a) and the inside surface of the hub (1b), must be cleaned and degreased thoroughly. The inside surface of the shrink disc (2a) and the outside surface of the hub (2b) also need cleaning and oiling slightly, making sure the oil does not reach surfaces that have already been cleaned and degreased (1a and 1b).

Vor der Montage der Schrumpfscheibe müssen die mit \triangle gekennzeichneten Flächen, d.h. die Zentrierungsfläche der Welle (1a) und die Innenseite der Nabe (1b) gereinigt und sorgfältig entfettet werden. Außerdem die Innenseite der Schrumpfscheibe (2a) und die Außenseite der Nabe (2b) leicht ölen. Dabei darauf achten, dass die bereits gereinigten und entfetteten Flächen 1a und 1b nicht mit dem Öl in Berührung kommen.

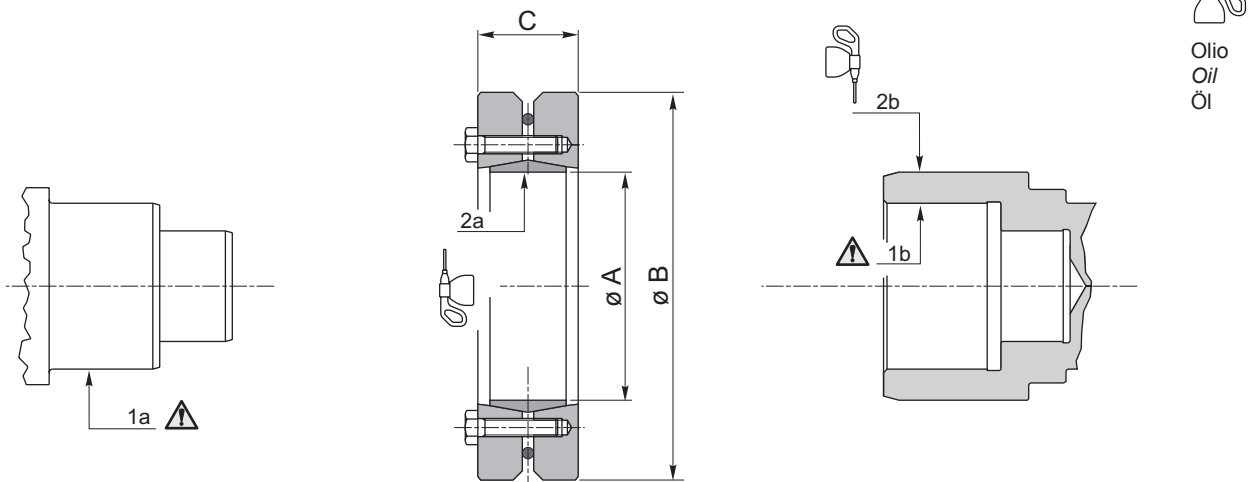

| | A | B | C | Code |
|----------------------------------|-----|-----|------|----------|
| RR310 MH RR510 MH RR710 MH | 100 | 170 | 44 | 154B3090 |
| RR810 MH | 125 | 215 | 54 | 154F4654 |
| RR1010 MH | 140 | 230 | 60.5 | 154F3778 |
| RR1700 MH RR1700 BH | 165 | 290 | 71 | 154F6499 |

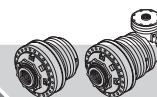

13.2 Frettes de serrage par frottement

Avant de monter la frette de serrage par frottement, nettoyer et dégraisser soigneusement les surfaces indiquées par un \triangle , c'est-à-dire la surface de centrage de l'arbre (1a) et la surface intérieure du moyeu (1b). De plus, il faut nettoyer et huiler légèrement la surface interne de la frette de serrage (2a) et la surface extérieure du moyeu (2b), en veillant à ce que l'huile n'atteigne pas les surfaces 1a et 1b déjà propres et dégraissées.

13.2 Engargoladores por fricción

Antes de proceder con el montaje del engargolador por fricción, es necesario limpiar y desengrasar cuidadosamente las superficies indicadas con \triangle , es decir la superficie de centrado del eje (1a) y la superficie interna del cubo (1b). Además, es necesario limpiar y aceitar ligeramente la superficie interna del engargolador (2a) y la superficie externa del cubo (2b), procurando que el aceite no alcance las superficies ya limpiadas y desengrasadas (1a y 1b).

13.2 Encaixadores por atrito

Antes de proceder à montagem do encaixador por atrito, é necessário limpar e desengordurar perfeitamente as superfícies indicadas com \triangle , ou seja, a superfície de centralização do veio (1a) e a superfície interna do cubo (1b). Além disso, é necessário limpar e olear ligeiramente a superfície interna do encaixador (2a) e a superfície externa do cubo (2b), fazendo de modo que o óleo não chegue às superfícies que já foram limpas e desengorduradas (1a e 1b).

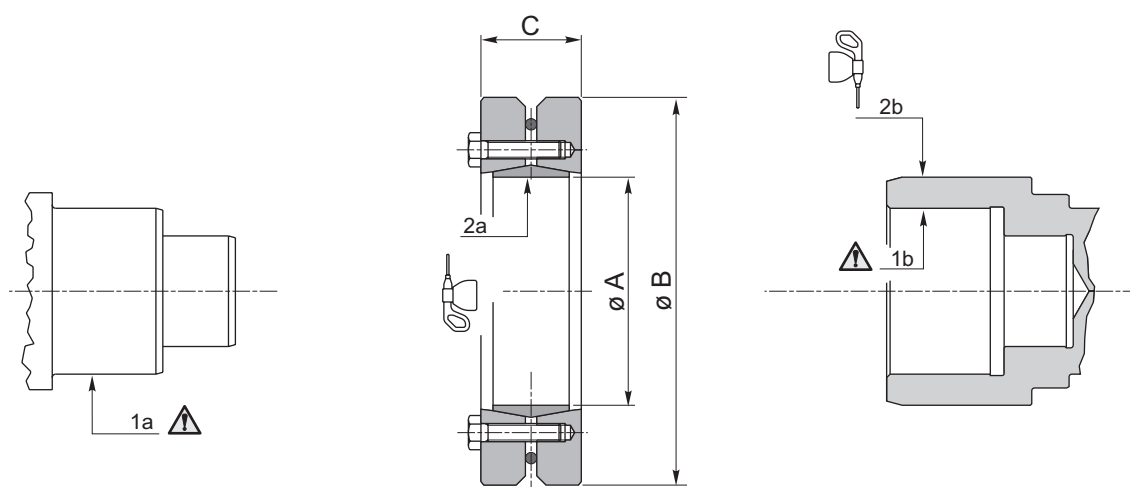

| | A | B | C | Code |
|----------------------------------|-----|-----|------|----------|
| RR310 MH RR510 MH RR710 MH | 100 | 170 | 44 | 154B3090 |
| RR810 MH | 125 | 215 | 54 | 154F4654 |
| RR1010 MH | 140 | 230 | 60.5 | 154F3778 |
| RR1700 MH RR1700 BH | 165 | 290 | 71 | 154F6499 |

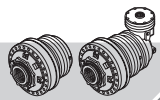

Solo in caso di disassemblaggio del calettatore e successivo montaggio, si dovrà provvedere a pulire ed ingrassare le superfici coniche del calettatore ed il gambo ed il sottotesta delle viti con grasso contenente additivi per alta pressione (MoS2).

Only if the shrink disc is removed and then remounted must its conical surfaces as well as the shank and underneath of the screws' heads be cleaned and greased using a grease containing high pressure additives (MoS2).

Nur beim Auseinanderbauen der Schrumpfscheibe und der anschließenden Montage müssen die Kegelflächen der Schrumpfscheibe, der Schaft und der Unterkopf der Schrauben sauber gemacht und mit Fett geschmiert werden, das Additive für Hochdruck (MoS2) enthält.

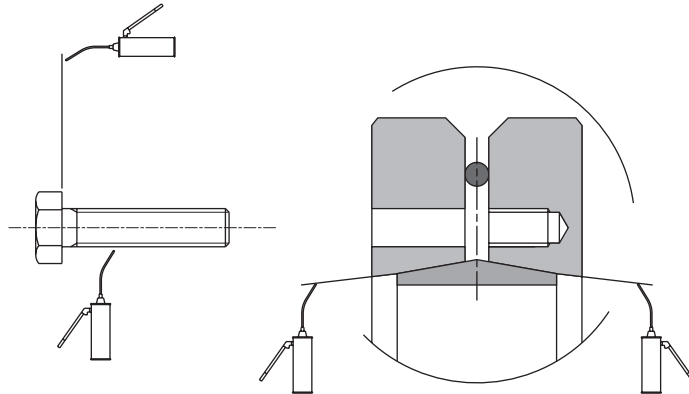



Grasso MoS2
MoS2 grease
Schmierfett MoS2

Serrare le viti alla coppia indicata nella seguente tabella:

Tighten the screws to the torque given in the following table:

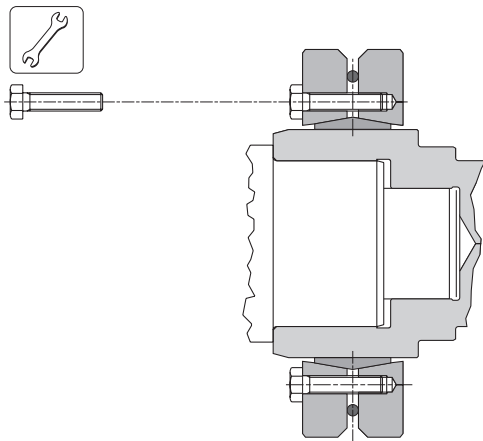
Die Schrauben mit den in der folgenden Tabelle angegebenen Anzugsmomenten anziehen:



| |  [Nm] |
|----------------------------------|---|
| RR310 MH RR510 MH RR710 MH | 30 |
| RR810 MH | 59 |
| RR1010 MH | 100 |
| RR1700 MH RR1700 BH | 250 |

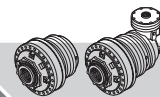

FR ES PT

Seulement en cas de désassemblage de la frette de serrage et montage successif, il faudra nettoyer et graisser les surfaces coniques de la frette de serrage ainsi que la tige et le collet des vis avec de la graisse contenant des additifs pour haute pression (MoS2).

Sólo en caso de desmontaje del engargolador y sucesivo montaje, habrá que proceder a limpiar y desengrasar las superficies cónicas del engargolador y el cuerpo y la parte de debajo de las cabezas de los tornillos con grasa que contenga aditivos para alta presión (MoS2).

Somente no caso de desmontagem e sucessiva montagem do encaixador, se deve limpar e lubrificar as superfícies cônicas do encaixador e a haste e a parte inferior da cabeça dos parafusos com graxa contendo aditivos para alta pressão (MoS2).

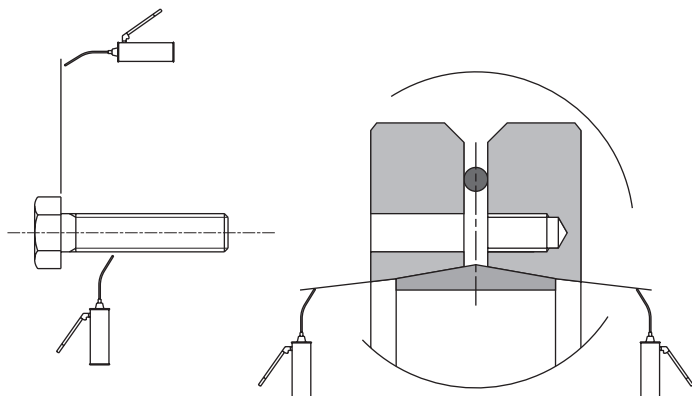



Graisse MoS2
Grasa MoS2
Graxa MoS2

Serrer les vis suivant le couple indiqué sur le tableau suivant:

Apretar los tornillos con el valor de par indicado en la tabla siguiente:

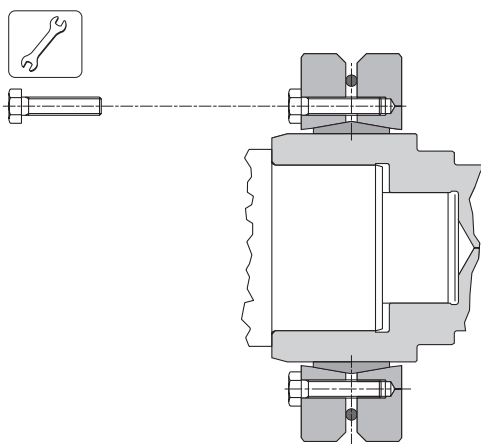
Apertar os parafusos ao par indicado na tabela a seguir:



| |  [Nm] |
|----------------------------------|---|
| RR310 MH RR510 MH RR710 MH | 30 |
| RR810 MH | 59 |
| RR1010 MH | 100 |
| RR1700 MH RR1700 BH | 250 |

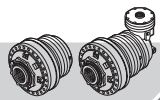

13.3 Bracci di reazione

Di seguito sono indicate le dimensioni suggerite per la realizzazione dei bracci di reazione, da utilizzare in abbinamento al calettatore per attrito, nel caso di riduttore con uscita tipo MH.

Nel caso di braccio di reazione a singolo fulcro, si raccomanda di rispettare tassativamente la quota H_{min} , indicata in tabella, e l'angolo di 90° .

Prima del montaggio occorre pulire e sgrassare i piani di battuta e le superfici di centraggio, che devono essere esenti da verniciatura.

13.3 Torque arms

Below are the dimensions recommended for implementing the torque arms, to use in combination with the friction shrink disc for reduction gears with an MH type output.

In the case of a single-fulcrum torque arm, it is essential to respect the H_{min} value, indicated in the table, and the 90° angle.

Before mounting, clean and degrease the resting tops and centring surfaces, which must be free from paint.

13.3 Reaktionsarme

Es folgt eine Auflistung der Abmessungen, die für die Realisierung der Reaktionsarme empfohlen werden, welche in Kombination mit der Schrumpfscheibe bei Planetengetrieben mit Ausgang MH verwendet werden.

Bei Reaktionsarmen mit nur einem Hebeldrehpunkt müssen der in der Tabelle angegebene Wert H_{min} und ein Winkel von 90° strikt beachtet werden.

Vor der Montage müssen die Auflageflächen und die Zentrierungsflächen gereinigt und entfettet werden. Sicherstellen, dass sie keine Lackreste aufweisen.

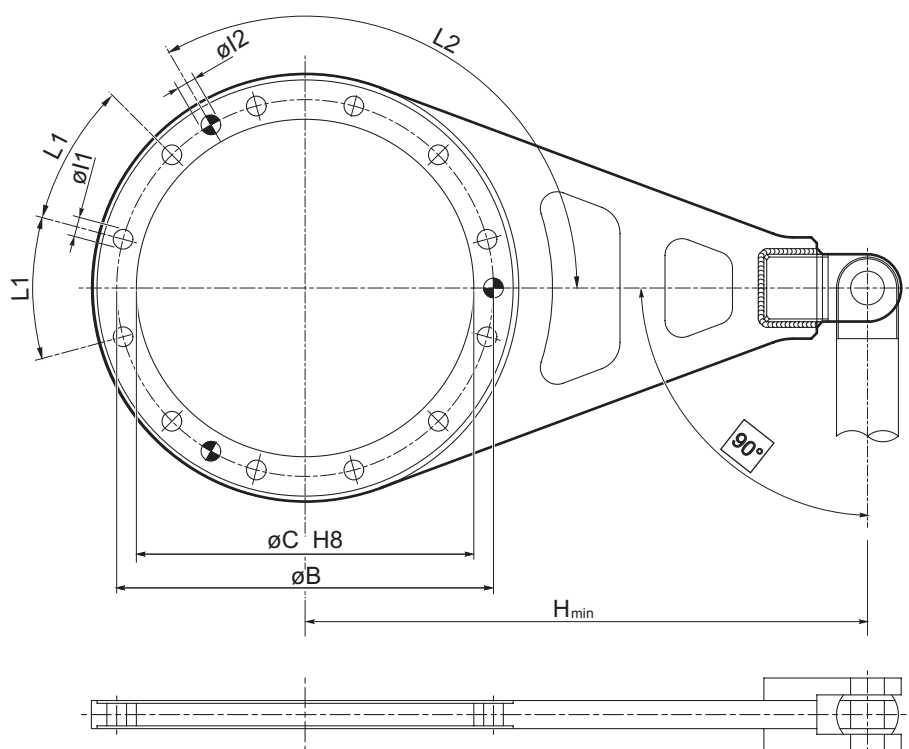

| | B | C | H_{min} | I1 | L1 | I2 | L2 |
|----------------------|-----|-----|-----------|-----------|-----|--------|------|
| RR310 MH | 190 | 150 | 95 | 14.5 n°8 | 45° | - | - |
| RR510 MH RR710 MH | 190 | 150 | 125 | 14.5 n°8 | 45° | - | - |
| RR810 MH | 250 | 200 | 125 | 13 n°15 | 24° | - | - |
| RR1010 MH | 295 | 230 | 147.5 | 14.5 n°12 | 30° | - | - |
| RR1700 MH | 314 | 278 | 320 | 15 n°12 | 30° | 12 n°3 | 120° |
| RR1700 BH | 295 | 230 | 235 | 17 n°12 | 30° | - | - |

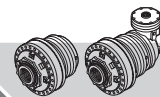

13.3 Bras de torsion

Ci-après figurent les dimensions recommandées pour la réalisation des bras de torsion, à utiliser en association avec la frette de serrage par frottement, en cas de réducteur avec sortie type MH.

En cas de bras de torsion à un pivot, il est fortement conseillé de respecter la cote H_{min} , indiquée sur le tableau, et l'angle de 90° .

Avant le montage, nettoyer et dégraisser les plans de butée et les surfaces de centrage, qui doivent être dépourvues de toute trace de peinture.

13.3 Brazos de reacción

A continuación se indican las medidas aconsejadas para realizar los brazos de reacción, a utilizar en combinación con el engargolador por fricción, en el caso de reductor con salida de tipo MH.

En el caso de brazo de reacción con fulcro individual, se recomienda respetar tajantemente la cota H_{min} , indicada en la tabla, y el ángulo de 90° .

Antes de efectuar el montaje es necesario limpiar y desengrasar los planos de contacto y las superficies de centrado, que no deben tener pintura.

13.3 Braços de reação

A seguir estão indicadas as dimensões sugeridas para a realização dos braços de reação, a utilizar juntamente com o encaixador por atrito, no caso de redutor com saída tipo MH.

No caso de braço de reação de fulcro único, recomenda-se respeitar absolutamente a cota H_{min} , indicada na tabela, e o ângulo de 90° .

Antes da montagem é necessário limpar e desengordurar os planos de contato e as superfícies de centralização, que devem ser isentas de pintura.

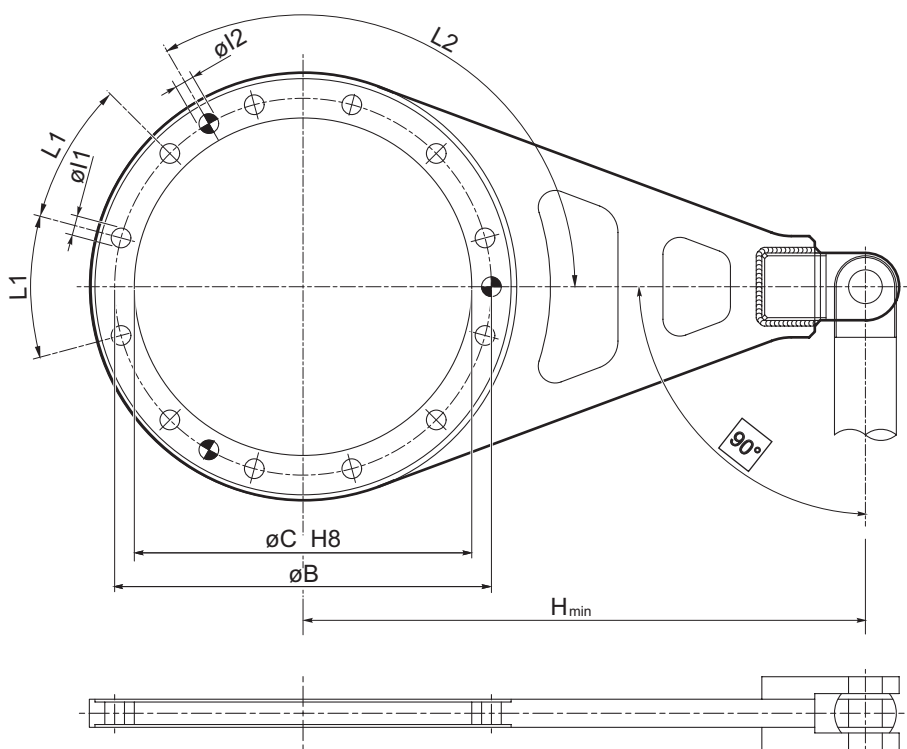

| | B | C | H_{min} | I1 | L1 | I2 | L2 |
|----------------------|-----|-----|-----------|-----------|-----|--------|------|
| RR310 MH | 190 | 150 | 95 | 14.5 n°8 | 45° | - | - |
| RR510 MH RR710 MH | 190 | 150 | 125 | 14.5 n°8 | 45° | - | - |
| RR810 MH | 250 | 200 | 125 | 13 n°15 | 24° | - | - |
| RR1010 MH | 295 | 230 | 147.5 | 14.5 n°12 | 30° | - | - |
| RR1700 MH | 314 | 278 | 320 | 15 n°12 | 30° | 12 n°3 | 120° |
| RR1700 BH | 295 | 230 | 235 | 17 n°12 | 30° | - | - |

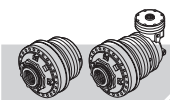

Le istruzioni per la selezione dei riduttori contenute nel presente catalogo sono puramente indicative.

Si prega di contattare il Servizio Tecnico Reggiana Riduttori per una selezione ottimale dei riduttori e per le necessarie verifiche aggiuntive.

Reggiana Riduttori si riserva la facoltà di modificare, senza alcun preavviso, i dati tecnici o dimensionali contenuti nel presente catalogo, allo scopo di migliorare il prodotto.

E' vietata la riproduzione totale o parziale del presente catalogo, senza autorizzazione scritta da parte di Reggiana Riduttori s.r.l.

Les instructions utiles au choix des réducteurs sont données, sur ce catalogue, à titre purement indicatif.

Contactez le Service Technique Reggiana Riduttori pour choisir les réducteurs correspondant le mieux à vos besoins et pour les contrôles complémentaires indispensables.

Reggiana Riduttori se réserve le droit de modifier, sans avis préalable, les caractéristiques techniques ou dimensionnelles figurant sur ce catalogue, dans le but d'améliorer le produit.

La reproduction totale ou partielle de ce catalogue est interdite sans autorisation écrite de la part de Reggiana Riduttori s.r.l.

The instructions for selecting the reduction gears in this catalogue are purely indicative. Please contact the Reggiana Riduttori Technical Service for the best selection of the reduction gears and for the necessary additional checks.

Reggiana Riduttori reserves the right to change, without prior notice, the technical or dimensional data in this catalogue with the purpose of improving the product.

It is forbidden to reproduce this catalogue, totally or partially, without written authorisation from Reggiana Riduttori s.r.l.

Las instrucciones para la selección de los reductores presentadas en este catálogo son puramente indicativas.

Se ruega contactar con el Servicio Técnico de Reggiana Riduttori para una selección óptima de los reductores y para las necesarias comprobaciones adicionales.

Reggiana Riduttori se reserva la facultad de modificar, sin previo aviso, los datos técnicos o dimensionales presentados en este catálogo, a fin de mejorar el producto.

Se prohíbe la reproducción, total o parcial, del presente catálogo, sin previa autorización por escrito de Reggiana Riduttori s.r.l.

Bei den Hinweisen zur Auswahl der Planetengetriebe im vorliegenden Katalog handelt es sich um reine Anhaltswerte.

Für eine optimale Auswahl der Planetengetriebe und die erforderlichen zusätzlichen Prüfungen halten Sie bitte mit dem Technischen Kundendienst von Reggiana Riduttori Rücksprache.

Die Firma Reggiana Riduttori behält sich das Recht vor, jederzeit und ohne Vorankündigung die technischen Daten und Abmessungen, die im vorliegenden Katalog angegeben sind, zu ändern in der Absicht, das Produkt zu verbessern.

Die Wiedergabe des vorliegenden Katalogs oder Teilen davon ohne vorherige schriftliche Genehmigung durch die Firma Reggiana Riduttori S.r.l. ist verboten.

As instruções relativas à selecção dos reductores contidas no presente catálogo são fornecidas a título meramente informativo.

Agredecemos que contactem o Serviço Técnico Reggiana Riduttori para a selecção otimal dos reductores e posteriores verificações.

Reggiana Riduttori reserva-se a facultade de modificar, sem obrigação de pré aviso, os dados técnicos o as dimensões contidas no presente catálogo, com o objectivo de melhorar o produto.

É proibida a reprodução total ou parcial do presente catálogo, sem prévia autorização escrita da parte da Reggiana Riduttori S.r.l.

**SERIE
2000**

**AA REGGIANA
RIDUTTORI**

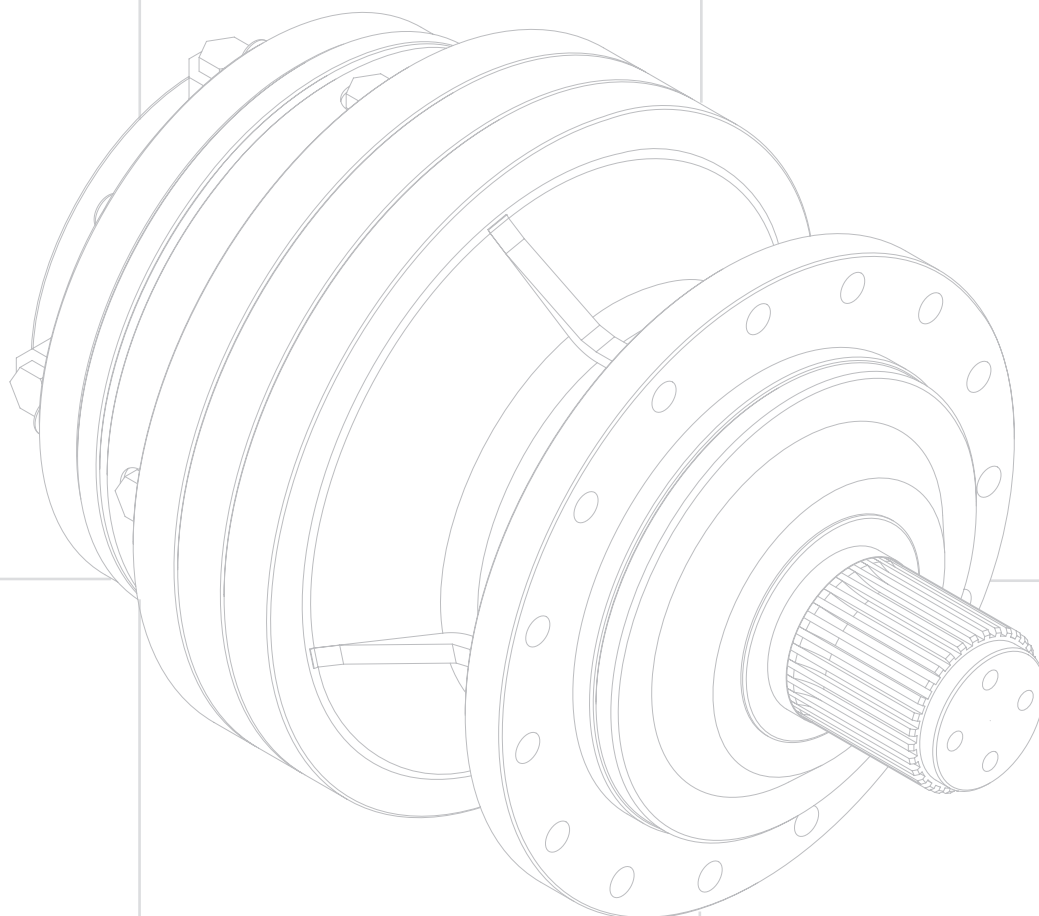

C200-1200-00



COMPANY WITH
QUALITY SYSTEM
CERTIFIED BY DNV
= ISO 9001 =



REGGIANA RIDUTTORI S.r.l.

Via Martiri di Marzabotto,7
42020 S. Polo d'Enza (RE) ITALY
tel. +39.0522.259111 - fax +39.0522.874321
info@reggianariduttori.com
www.reggianariduttori.com